

Component Procedures: Blower Motor Switch

Table of Contents

1. Parts and Labor (itype_189)
2. Components (itype_392)
3. Components (itype_32)
4. Procedures (itype_376)
5. Technician Safety Information (itype_15)
6. Mechanical (including Torque) (itype_28)
7. Component Tests and General Diagnostics (itype_383)

Component Procedures: Blower Motor Switch

Parts and Labor (itype_189)

Parts

Qualifier	Part #	Name	Price	Note
Blower Motor Switch	4882790	Blower Motor Switch	0.00	

Labor

Operation	Qualifier Path	Skill	Std Hrs	Wty Hrs
Replace	Blower Motor Switch, R&R	B	0.5	0.3

Components (itype_392)

SYSTEM DESCRIPTION

The heater-only or heater-A/C

blower motor

is controlled by a four position rotary-type

blower motor switch

, mounted in the heater-A/C control panel. The switch allows the selection of one of four blower motor speeds,

but can only be turned off by selecting the Off position with the heater-A/C

mode control switch

The blower motor switch receives ignition-switched battery current through the mode control switch from a fuse

in the fuseblock module. The blower motor switch directs the battery current to the

blower motor resistor

, or to the

blower motor relay

, as required to achieve the selected blower motor speed.

The blower motor switch cannot be repaired and, if faulty or damaged, it must be replaced. The blower motor

switch knob is available for service replacement.

Components (itype_32)

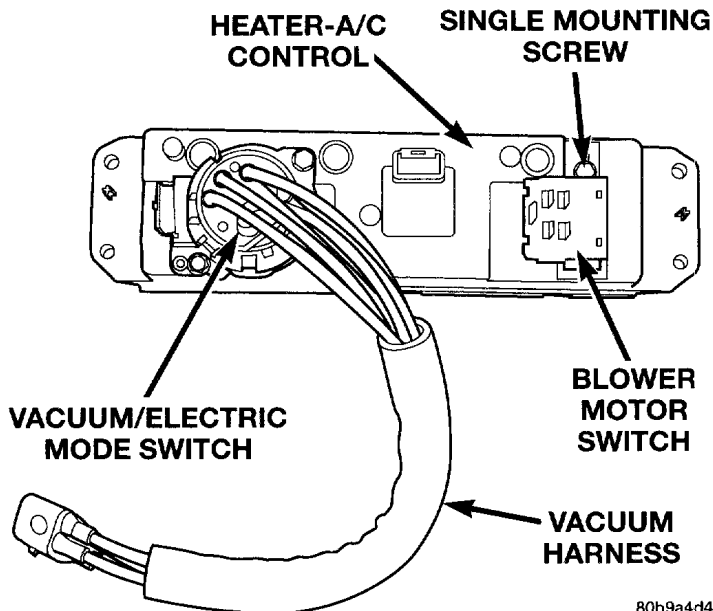

Procedures (itype_376)

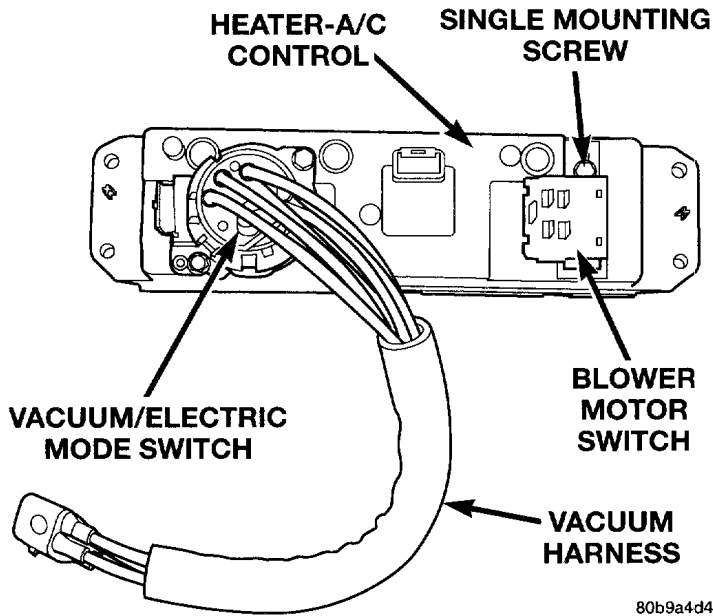

Technician Safety Information (itype_15)

WARNING: ON VEHICLES EQUIPPED WITH AIRBAGS, REFER TO RESTRAINT SYSTEMS / AIR BAG SYSTEMS BEFORE ATTEMPTING ANY STEERING WHEEL, STEERING COLUMN, OR INSTRUMENT PANEL COMPONENT DIAGNOSIS OR SERVICE. FAILURE TO TAKE THE PROPER PRECAUTIONS COULD RESULT IN ACCIDENTAL AIRBAG DEPLOYMENT AND POSSIBLE PERSONAL INJURY

Mechanical (including Torque) (itype_28)

Tighten the heater-A/C control and switch mounting screws to 2.2 Nm (20 in. lbs.)

Component Tests and General Diagnostics (itype_383)

WARNING: ON VEHICLES EQUIPPED WITH AIR-BAGS, REFER TO AIRBAG AND SEAT BELTS/AIR BAGS BEFORE ATTEMPTING ANY STEERING WHEEL, STEERING COLUMN, OR INSTRUMENT PANEL COMPONENT DIAGNOSIS OR SERVICE. FAILURE TO TAKE THE PROPER PRECAUTIONS COULD RESULT IN ACCIDENTAL AIR-BAG DEPLOYMENT AND POSSIBLE PERSONAL INJURY

1. Turn the ignition switch to the On position and check for battery voltage at the fuse in the fuseblock module. If OK, go to Step 2. If not OK, repair the shorted circuit or component as required and replace the faulty fuse.
2. Turn the ignition switch to the Off position. Disconnect and isolate the battery negative cable. Remove the heater-A/C control from the instrument panel, but do not unplug the wire harness connectors. Connect the battery negative cable. Turn the ignition switch to the On position. Check for battery voltage at the fused ignition switch output (run) circuit cavity of the heater-A/C mode control switch wire harness connector. If OK, go to Step 3. If not OK, repair the open circuit to the fuseblock module as required.
3. Select any one of the heater-A/C mode control positions except Off to turn the system on. Check for battery voltage at the low blower motor driver circuit cavity of the heater-A/C mode control switch wire harness connector. If OK, go to Step 4. If not OK, replace the faulty heater-A/C mode control switch.
4. Check for battery voltage at the low blower motor driver circuit cavity of the blower motor switch wire harness connector. If OK, go to Step 5. If not OK, repair the open circuit to the heater-A/C mode control

switch wire harness connector as required.

5. Check for battery voltage at each of the remaining blower motor switch wire harness connector cavities as you move the switch to each blower motor speed position. Voltage should be present in each cavity at only one switch position. If OK, see the diagnosis for the blower motor resistor and/or the blower motor relay . If not OK, replace the faulty blower motor switch.