

Component Procedures: Charging System

Table of Contents

1. Parts and Labor (itype_189)
2. Charging System Operation (Article 2086164)
3. Charging System Diagrams (Article 2088357)
4. Customer Safety Information (itype_14)
5. Technician Safety Information (itype_15)
6. Vehicle Damage Warnings (itype_16)
7. Volts and Amps (Article 2088745)
8. Voltage (Article 2088746)
9. Mechanical (including Torque) (itype_28)
10. Description of On-Board Diagnostics (Article 2085686)
11. Initial Inspection and Diagnostic Overview (itype_377)

Component Procedures: Charging System

Parts and Labor (itype_189)

Labor

Operation	Qualifier Path	Skill	Std Hrs	Wty Hrs
Inspect	Charging Circuit, Inspect	B	0.5	0.0

Charging System Operation (Article 2086164)

SYSTEM OPERATION

The charging system consists of:

- Generator
- Electronic Voltage Regulator (EVR)
- circuitry within the Powertrain Control Module (PCM)
- Ignition switch
- Battery (refer to Battery for information)
- Battery temperature sensor
- Generator Lamp (if equipped)
- Check Gauges Lamp (if equipped)
- Voltmeter (refer to Instrument Panel and Gauges for information)

The charging system is turned on and off with the ignition sw

itch. The system is on when the engine is running and the ASD relay is energized. When the ASD relay is on, voltage is supplied to the ASD relay sense circuit at the PCM. This voltage is connected through the PCM and supplied to one of the generator field terminals (Gen. Source +) at the back of the generator.

The amount of DC current produced by the generator is controlled by the EVR (field control) circuitry contained within the PCM. This circuitry is connected in series with the second rotor field terminal and ground

. A battery temperature sensor, located in the battery tray

housing, is used to sense battery temperature. This temperature data, along with data from monitored line voltage, is used by the PCM to vary the battery charging rate. This is done by cycling the ground path to control the strength of the rotor magnetic field. The PCM then compensates and regulates generator current output accordingly

All vehicles are equipped with On-Board Diagnostics (OBD)

. All OBD-sensed systems, including EVR (field control) circuitry, are monitored by the PCM. Each monitored circuit is assigned a Diagnostic Trouble Code (DTC). The PCM will store a DTC in electronic memory for certain failures it detects.

The Check Gauges Lamp (if equipped) monitors: charging system voltage, engine coolant temperature and engine oil pressure. If an extreme condition is indicated, the lamp will be illuminated. This is done as reminder to check the three gauges. The signal to activate the lamp is sent via the CCD bus circuits. The lamp is located on the instrument panel. Refer to Instrument Panel and Gauges for additional information.

Charging System Diagrams (Article 2088357)

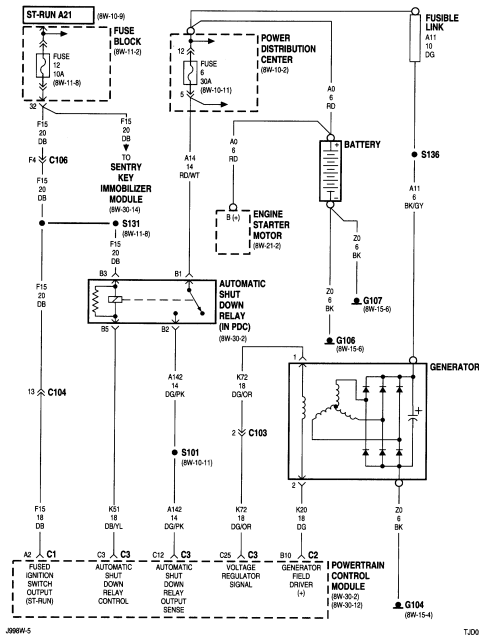

Customer Safety Information (itype_14)

1. Be certain that battery polarity is correct when servicing units. Reversed battery polarity will damage rectifiers and regulators.
2. If booster battery is used for starting, be sure to use correct polarity in hook up.
3. When a fast charger is used to charge a vehicle battery, the vehicle battery cable should be disconnected unless the fast charger is equipped with a special Alternator Protector, in which case the vehicle battery cables need not be disconnected. Also the fast charger should never be used to start a vehicle as damage to rectifiers will result.
4. Lead connections to the grounded rectifiers (negative) should never be soldered as the excessive heat may damage the rectifiers.
5. Unless the system includes a load relay or field relay, grounding the alternator output terminal will damage the alternator and/or circuits. This is true even when the system is not in operation since no circuit breaker is used and the battery is applied to the alternator output terminal at all times. The field or load relay acts as a circuit breaker in that it is controlled by the ignition switch.
6. When adjusting the voltage regulator, do not short the adjusting tool to the regulator base as the regulator may be damaged. The tool should be insulated by taping or by installing a plastic sleeve.
7. Before making any "on vehicle" tests of the alternator or regulator, the battery should be checked and the circuit inspected for faulty wiring or insulation, loose or corroded connections and poor ground circuits.
8. Check alternator belt tension to be sure the belt is tight enough to prevent slipping under load.
9. The ignition switch should be off and the battery ground cable disconnected before making any test connections to prevent damage to the system.
10. The vehicle battery must be fully charged or a fully charged battery may be installed for test purposes.

Technician Safety Information (itype_15)

1. Be certain that battery

- polarity is correct when servicing units. Reversed battery polarity will damage rectifiers and regulators.
2. If booster battery is used for starting, be sure to use correct polarity in hook up.
 3. When a fast charger is used to charge a vehicle battery, the vehicle battery cable should be disconnected unless the fast charger is equipped with a special Alternator Protector, in which case the vehicle battery cables need not be disconnected. Also the fast charger should never be used to start a vehicle as damage to rectifiers will result.
 4. Lead connections to the grounded rectifiers (negative) should never be soldered as the excessive heat may damage the rectifiers.
 5. Unless the system includes a load relay or field relay, grounding the alternator output terminal will damage the alternator and/or circuits. This is true even when the system is not in operation since no circuit breaker is used and the battery is applied to the alternator output terminal at all times. The field or load relay acts as a circuit breaker in that it is controlled by the ignition switch.
 6. When adjusting the voltage regulator, do not short the adjusting tool to the regulator base as the regulator may be damaged. The tool should be insulated by taping or by installing a plastic sleeve.
 7. Before making any "on vehicle" tests of the alternator or regulator, the battery should be checked and the circuit inspected for faulty wiring or insulation, loose or corroded connections and poor ground circuits.
 8. Check alternator belt tension to be sure the belt is tight enough to prevent slipping under load.
 9. The ignition switch should be off and the battery ground cable disconnected before making any test connections to prevent damage to the system.
 10. The vehicle battery must be fully charged or a fully charged battery may be installed for test purposes.

Vehicle Damage Warnings (itype_16)

1. Ensure battery polarity is correct when servicing units. Reversed battery polarity will damage rectifiers and regulators.
2. If booster battery is used for starting, be sure to use correct polarity in hook up.
3. When a fast charger is used to charge a vehicle battery, the vehicle battery cable should be disconnected unless the fast charger is equipped with a special alternator protector, in which case the vehicle battery cables need not be disconnected. Also the fast charger should never be used to start a vehicle as damage to rectifiers will result.
4. Lead connections to the grounded rectifiers (negative) should never be soldered, as the excessive heat may damage the rectifiers.
5. Unless the system includes a load relay or field relay, grounding the alternator output terminal will damage the alternator and/or circuits. This is true even when the system is not in operation, since no circuit breaker is used and the battery is applied to the alternator output terminal at all times. The field or load relay acts as a circuit breaker in that it is controlled by the ignition switch.
6. Before making any in-vehicle tests of the alternator or regulator, the battery should be checked and the circuit inspected for faulty wiring or insulation, loose or corroded connections and poor ground circuits.
7. Check alternator belt tension to ensure belt is tight enough to prevent slipping under load.
8. The ignition switch should be off and the battery ground

cable disconnected before making any test connections to prevent damage to the system.

9. The vehicle battery must be fully charged or a fully charged battery may be installed for test purposes.

Volts and Amps (Article 2088745)

Part Number = 56005684AB

Rated SAE Amps

81 amps

Minimum Test Amps

57 amps

Part Number = 56005685AB

117 amps

88 amps

Voltage (Article 2088746)

Powertrain Control Module

(PCM)

regulates

charging system

voltage by controlling the generator field source (+) circuit.

The voltage range is

12.9 to 15.0 volts

Mechanical (including Torque) (itype_28)

Description = Torque

Ground

Terminal Nut -

8.5 Nm (75 in. lbs.)

Harness Hold-down Nut -

Field Terminal Nuts -

2.8 Nm (25 in. lbs.)

Description of On-Board Diagnostics (Article 2085686)

The Powertrain Control Module (PCM) monitors critical input and output circuits of the charging system

, making sure they are operational. A Diagnostic Trouble Code (DTC) is assigned to each input and output circuit monitored by the On-Board Diagnostic (OBD) system. Some circuits are checked continuously and some are checked only under certain conditions.

Initial Inspection and Diagnostic Overview (itype_377)

The following procedures may be used to diagnose the charging system

if:

- the

generator

lamp (if equipped) is illuminated with the engine running

- the voltmeter (if equipped) does not register properly

- an undercharged or overcharged

battery

condition occurs.

- Remember that an undercharged battery is often caused by:

- accessories being left on with the engine not running

- a faulty or improperly adjusted switch that allows a lamp to stay on. See Ignition-Off Draw Test in Battery for more information.

Inspection

To perform a complete test of the charging system, refer to the appropriate Powertrain Diagnostic Procedures and the DRB scan tool. Perform the following inspections before attaching the scan tool.

1. Inspect the battery condition. Refer to Battery for procedures.

2. Inspect condition of

battery cable

terminals, battery posts, connections at engine block, starter solenoid and relay They should be clean and tight. Repair as required.

3. Inspect all fuses in both the fuseblock and Power Distribution Center

(PDC

) for tightness in receptacles. They should be properly installed and tight. Repair or replace as required.

4. Inspect generator mounting bolts for tightness. Replace or tighten bolts if required. Refer to the Generator/Service and Repair for torque specifications.

5. Inspect generator drive belt condition and tension. Tighten or replace belt as required.

6. Inspect automatic belt tensioner (if equipped).

7. Inspect generator electrical connections at generator field, battery output, and ground

terminal (if equipped). Also check generator ground wire connection at engine (if equipped). They should all be clean and tight. Repair as required.