

# Component Procedures: Electronic Noise Suppressor

## Table of Contents

1. Components (itype\_392)
2. Procedures (itype\_376)
3. Mechanical (including Torque) (itype\_28)

# Component Procedures: Electronic Noise Suppressor

## Components (itype\_392)

### DESCRIPTION

Radio Frequency Interference (RFI) and Electro Magnetic Interference (EMI)

noise suppression is accomplished primarily through circuitry internal to the radio receivers. These internal suppression devices are only serviced as part of the radio receiver.

External suppression devices that are used on this vehicle to control RFI or EMI noise include the following:

- Radio antenna base ground
- Radio receiver chassis ground wire or strap
- Engine-to-body ground strap
- Engine-to-frame ground strap
- Resistor-type spark plugs
- Radio suppression-type secondary ignition wiring.

For more information on the spark plugs and secondary ignition components, refer to Ignition System in the Description and Operation of Ignition System.

## Procedures (itype\_376)

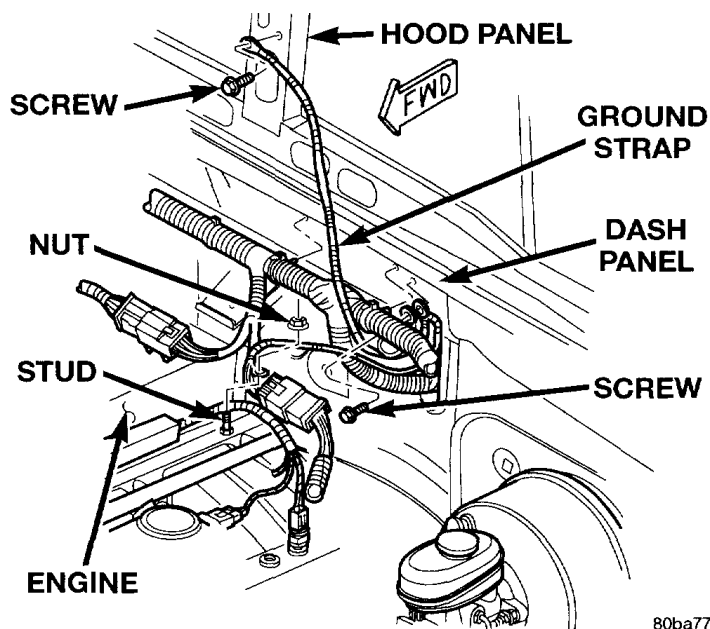

80ba7783

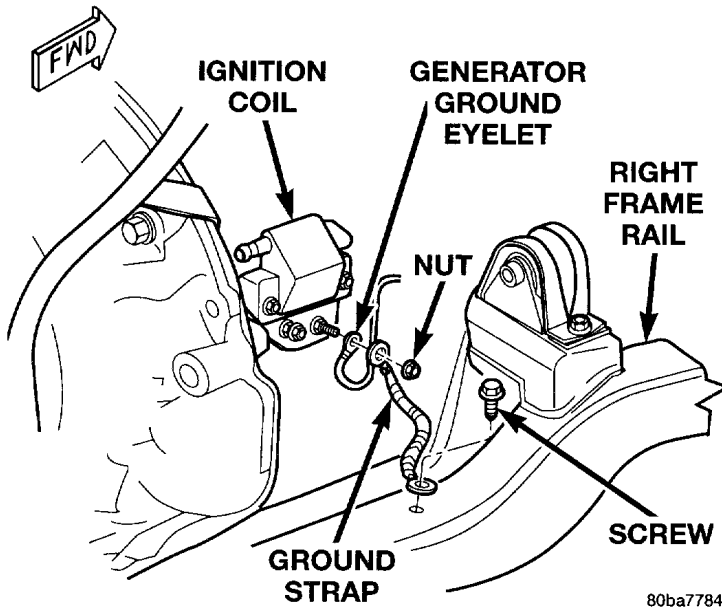

### **Mechanical (including Torque) (itype\_28)**

Tighten the nut that secures the engine-to-body ground strap eyelet to the stud on the left upper rear corner of the engine cylinder head nut to 5.6 Nm (50 in. lbs.)

Tighten the screw that secures the engine-to-body ground strap eyelet to the dash panel. Tighten the screw to 48.5 Nm (430 in. lbs.)

Tighten the screw that secures the engine-to-body ground strap eyelet to the hood panel center reinforcement screw to 1.9 Nm (17 in. lbs.)

Tighten the screw that secures the engine-to-frame ground strap eyelet to the top of the right frame rail screw to 22.6 Nm (200 in. lbs.)

Tighten the nut that secures the engine-to-frame ground strap eyelet to the forward ignition coil mounting stud on the right side of the engine nut to