

Component Procedures: Manifold Pressure/Vacuum Sensor

Table of Contents

1. Parts and Labor (itype_189)
2. Components (itype_392)
3. Connector Views (itype_47)
4. Components (itype_32)
5. Procedures (itype_376)
6. Mechanical (including Torque) (itype_28)
7. Component Tests and General Diagnostics (itype_383)

Component Procedures: Manifold Pressure/Vacuum Sensor

Parts and Labor (itype_189)

Parts

Qualifier	Part #	Name	Price	Note
MAP Sensor > From 7/96	56029405	Electronic Engine Cont?	279.00	

Labor

Operation	Qualifier Path	Skill	Std Hrs	Wty Hrs
Replace	Map Sensor, R&R	B	0.3	0.2

Components (itype_392)

MANIFOLD ABSOLUTE PRESSURE

(
MAP
) SENSOR-
PCM
INPUT

The
MAP sensor

reacts to absolute pressure in the intake manifold. It provides an input voltage to the Powertrain Control Module

(PCM). As engine Toad changes, manifold pressure varies. The change in manifold pressure causes MAP sensor voltage to change. The change in MAP sensor voltage results in a different input voltage to the PCM. The input voltage level supplies the PCM with information about ambient barometric pressure during engine load while the engine is running. The PCM uses this input along with inputs from other sensors to adjust air-fuel mixture.

The MAP sensor is mounted on the side of the engine throttle body

. The sensor is connected to the throttle body with a rubber L-shaped fitting.

Connector Views (itype_47)

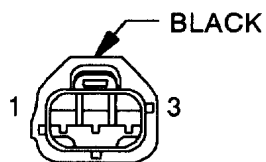

**MANIFOLD
ABSOLUTE
PRESSURE
SENSOR**

MANIFOLD ABSOLUTE PRESSURE SENSOR - BLACK 3 WAY

CAV	CIRCUIT	FUNCTION
1	K167 20BR/YL	SENSOR GROUND
2	K1 18DG/RD	MANIFOLD ABSOLUTE PRESSURE SENSOR SIGNAL
3	K7 200R	5V SUPPLY

Components (itype_32)

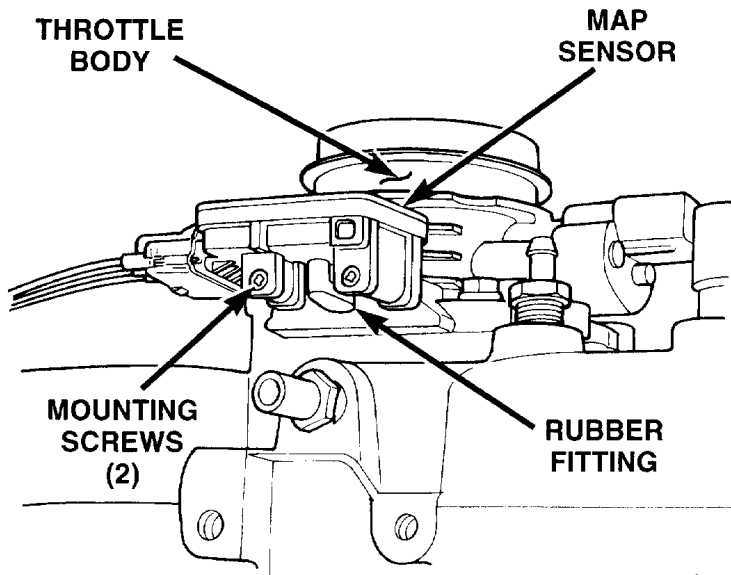

80a6f168

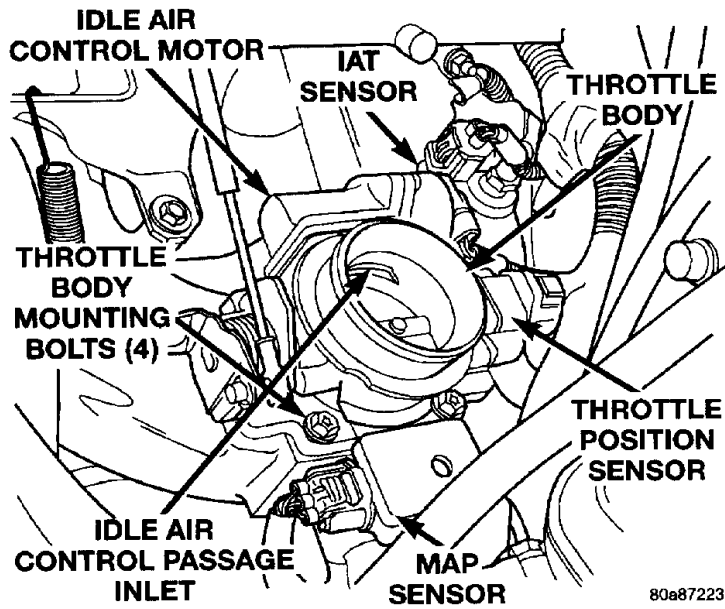

80a87223

Procedures (itype_376)

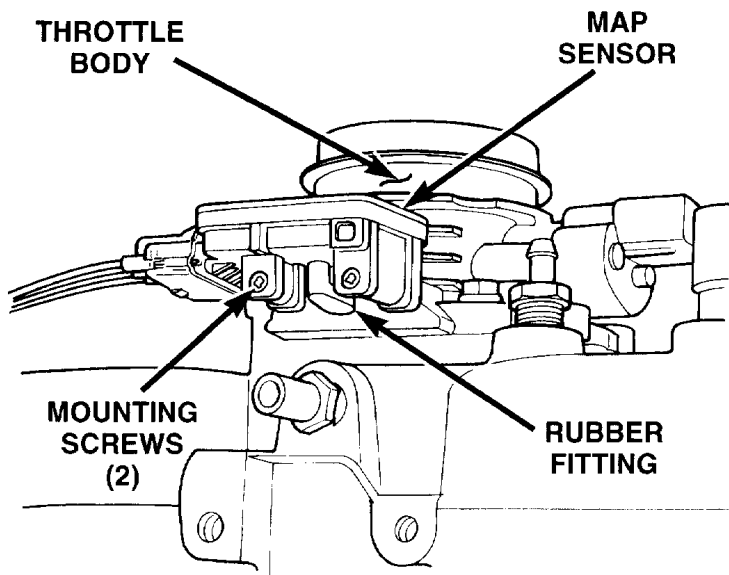
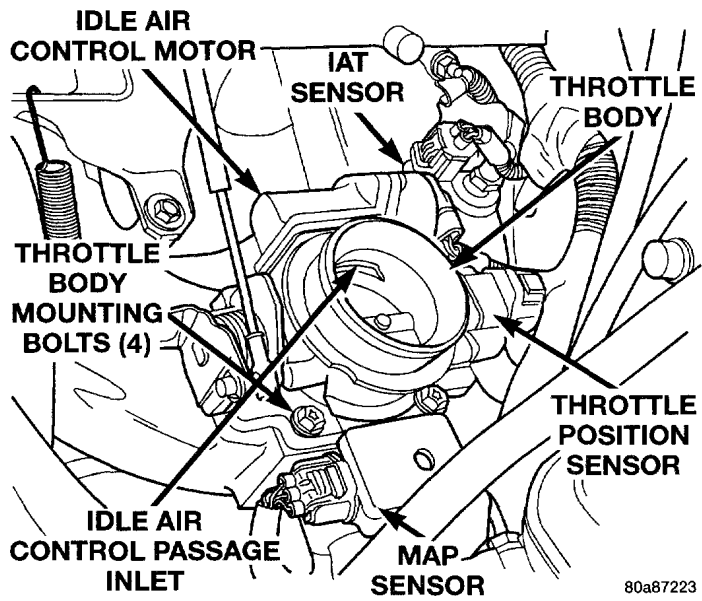

Mechanical (including Torque) (itype_28)

MAP Sensor Mounting Bolts (screws) 3 Nm

Component Tests and General Diagnostics (itype_383)

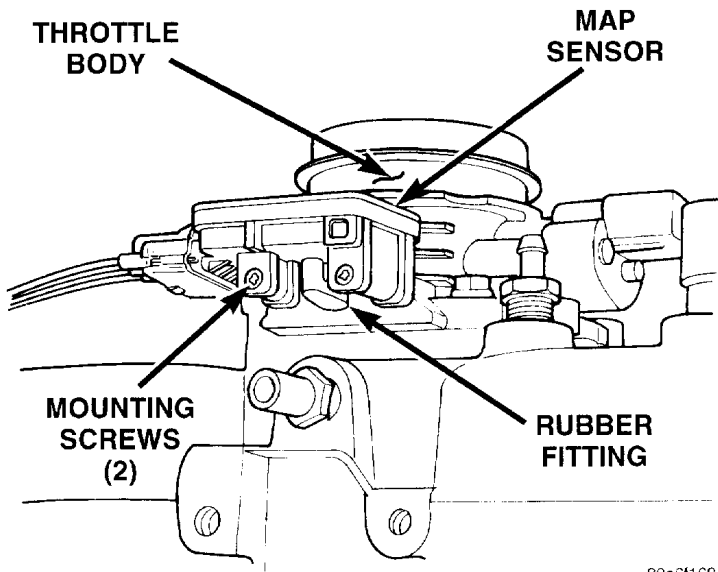

80a6f168

A = GROUND
B = OUTPUT VOLTAGE SIGNAL
C = 5-VOLT SUPPLY

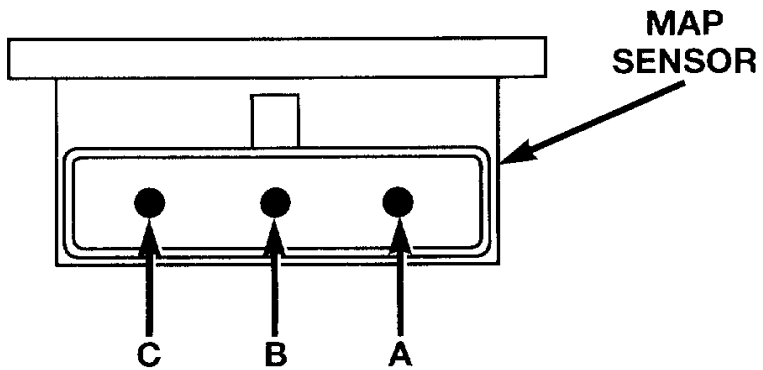

8056d9f7