

# **Component Procedures: Clutch Slave Cylinder**

## **Table of Contents**

1. Parts and Labor (itype\_189)
2. Clutch Hydraulic Linkage (Article 2083878)
3. Slave Cylinder, Bleeding Procedure (Article 2083879)

# Component Procedures: Clutch Slave Cylinder

## Parts and Labor (itype\_189)

### Labor

Operation	Qualifier Path	Skill	Std Hrs	Wty Hrs
Replace	External Mounted With Master Cylinder	B	1.3	0.9

### Clutch Hydraulic Linkage (Article 2083878)

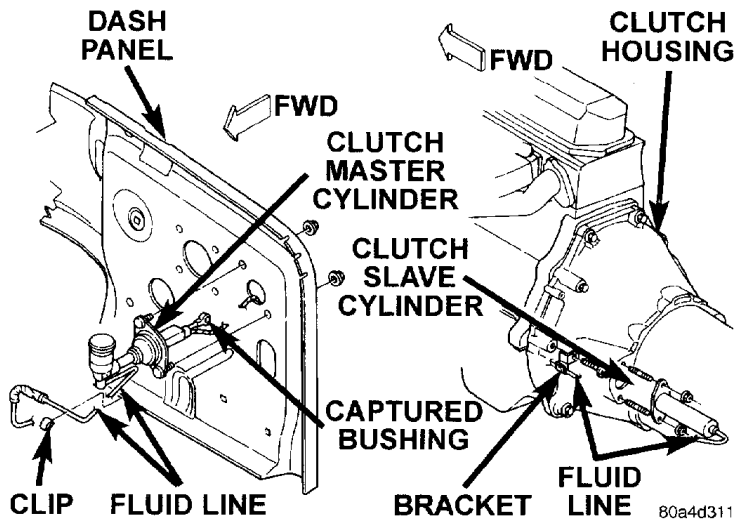

**Fig. 9 Slave Cylinder and Left Hand Drive Clutch Master Cylinder**

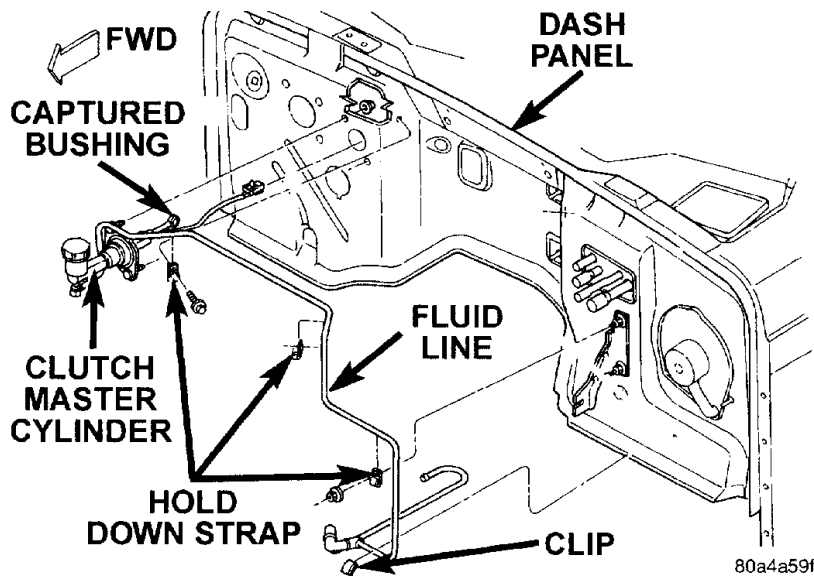

**Fig. 10 Right Hand Drive Clutch Master Cylinder**

### Slave Cylinder, Bleeding Procedure (Article 2083879)

No Bleeding Procedure

The clutch master cylinder

, slave cylinder

and connecting line are serviced as an assembly only. The linkage components cannot be overhauled or serviced

separately. The cylinders and connecting line are sealed units. Also note that removal/installation procedures for right and left hand drive models are basically the same. Only master cylinder location is different.