

Component Procedures: Information Bus

Table of Contents

1. Components (itype_392)
2. System Schematic (Article 2048281)
3. Computer Data Lines (Article 11235)

Component Procedures: Information Bus

Components (itype_392)

VEHICLE COMMUNICATION

The

Chrysler Collision Detection

multiplex

system

(

CCD bus

)

consists of a twisted pair of wires. These wires run from one module to another. They receive and deliver coded information between the modules. The information is coded to identify the message as well as the importance of the message. When there are multiple messages trying to access the

CCD

bus at one time, the code determines the message that has higher priority, which is then allowed to access the bus first.

The two wires of the twisted pair that make up the CCD multiplex system are called "bus (+)" (bus plus) and "bus (-)" (bus minus) respectively. Each wire has a measureable voltage level of approximately 2.5 volts

. In order to maintain the

on each line and provide a means of transportation for the coded messages, there is a voltage divider network". This network consists of the Instrument Cluster module which supplies bias and the

PCM

which supplies termination, Bias is the part of the voltage divider network that places both bus (+) and bus (-) at

. Termination in the circuitry is required to complete the voltage divider network and also provides some electromagnetic protection for the bus.

NOTE:

COMMUNICATION OVER THE BUS IS ESSENTIAL TO THE PROPER OPERATION OF THE VEHICLE'S ON-BOARD DIAGNOSTIC SYSTEM AND THE DRB. PROBLEMS WITH THE OPERATION OF THE BUS OR DRB MUST BE CORRECTED BEFORE PROCEEDING WITH DIAGNOSTIC TESTING. IF THERE IS A PROBLEM, REFER TO THE VEHICLE COMMUNICATION.

Bus Failure Messages

Short to Battery

- Either or both of the bus wires are shorted to the battery potential.

Short to 5 Volts

- Either or both of the bus wires are shorted to a 5-volt potential.

Short to Ground

- Either or both of the bus wires are shorted to ground.

Bus (+) & Bus (-) Shorted Together

- The two bus wires are shorted together.

No Termination

- The bus system has not lost connection with its terminator.

Bus Bias Level Too Low

- Either or both of the bus wire potentials are significantly below their normal

.

Bus Bias Level Too High

- Either or both of the bus wire potentials are significantly above their normal

No Bus Bias

- The bus system has lost connection with the VTSS module which provides bias.

Bus (+) Open

- The bus (+) wire has lost connection with termination and/or bias.

Bus (-) Open

- The bus (-) wire has lost connection with termination and/or bias.

Not Receiving Bus Messages Correctly

- The DRB cannot communicate over the bus and does not know why.

System Schematic (Article 2048281)

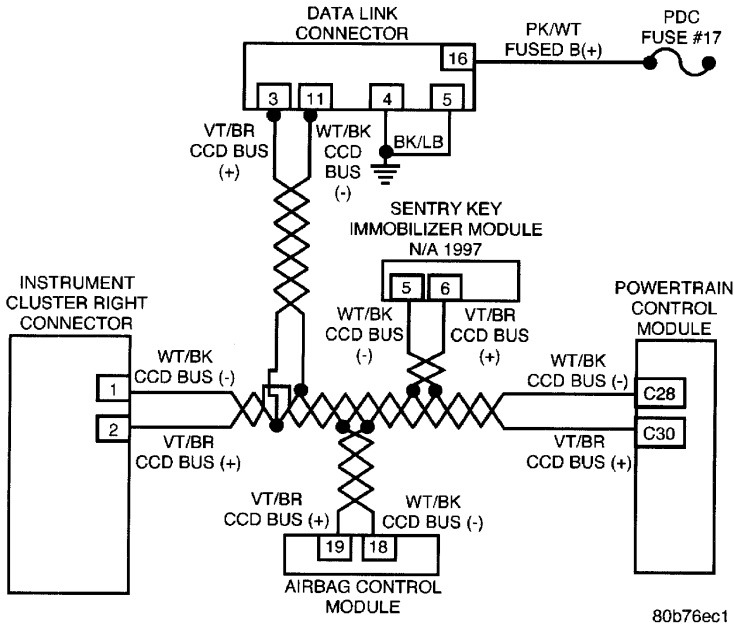

Computer Data Lines (Article 11235)

Computer Data Line s

Interactive Color (Non OE) diagrams for model years 2001 and older use a universal ground location diagram.

Click here for the diagram.

Page 1 of 1

