

Component Procedures: Shift Linkage

Table of Contents

1. NV231 Transfer Case (Article 2027280)
2. Parts and Labor (itype_189)
3. All Technical Service Bulletins (itype_100)
4. Customer Interest Bulletins (itype_109)
5. Noise (itype_156)
6. New / Updated Parts (itype_117)

Component Procedures: Shift Linkage

NV231 Transfer Case (Article 2027280)

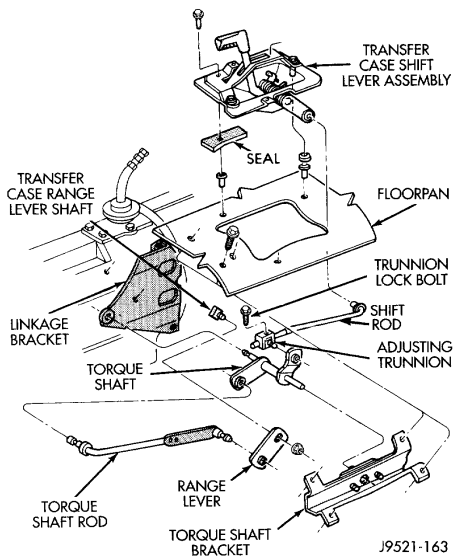

Fig. 87 Shift Linkage

Parts and Labor (itype_189)

Labor

Operation	Qualifier Path	Skill	Std Hrs	Wty Hrs
Replace	NP231 Non-Synchro, NV231 > Bellcrank to Case	C	0.7	0.4
Replace	NP231 Non-Synchro, NV231 > Bellcrank to Shift?	C	1.1	0.8

All Technical Service Bulletins (itype_100)

Tsbs

- Transfer Case Shifter - Creaking/Thumping Noise (21-09-98, 1998/07/31)

Customer Interest Bulletins (itype_109)

Tsbs

- Transfer Case Shifter - Creaking/Thumping Noise (21-09-98, 1998/07/31)

Noise (itype_156)

Tsbs

- Transfer Case Shifter - Creaking/Thumping Noise (21-09-98, 1998/07/31)

New / Updated Parts (itype_117)

Tsbs

- Transfer Case Shifter - Creaking/Thumping Noise (21-09-98, 1998/07/31)