

Component Procedures: Wheel Speed Sensor

Table of Contents

1. Parts and Labor (itype_189)
2. Wheel Speed Sensors and Tone Wheels (Article 2025484)
3. Connector Views (itype_47)
4. Wheel Speed Sensors (Article 2085337)
5. Front Wheel Speed Sensor Connectors (Article 2085327)
6. Rear Wheel Speed Sensor Connectors (Article 2085330)
7. Wheel Speed Sensor Replacement (Article 2025497)
8. Tightening Specifications (Article 2085314)

Component Procedures: Wheel Speed Sensor

Parts and Labor (itype_189)

Parts

Qualifier	Part #	Name	Price	Note
Front Speed Sensor	56027727	Anti-lock Brake Compon?	149.00	
Rear Speed Sensor > Right	52005932	Anti-lock Brake Compon?	163.00	
Rear Speed Sensor > Left	52005933	Anti-lock Brake Compon?	143.00	

Labor

Operation	Qualifier Path	Skill	Std Hrs	Wty Hrs
Replace	Front Sensor Ring > One Side	B	1.1	0.7
Replace	Front Speed Sensor	B	0.7	0.4
Replace	Rear Sensor Ring	B	1.2	0.8
Replace	Rear Speed Sensor	B	0.8	0.5

Wheel Speed Sensors and Tone Wheels (Article 2025484)

SENSORS

Wheel Speed Sensor

s and Tone Wheels: One wheel

speed sensor

(

WSS

is located at each wheel and sends a small AC signal to the control module (

CAB

). This voltage is generated by magnetic induction when a toothed sensor ring (tone wheel) passes by a stationary

magnetic sensor

(wheel speed sensor). The CAB converts the AC signals into digital signals for each wheel.

The

front wheel sensor

is attached to a boss in the steering knuckle. The tone wheel is an integral part of the front axle shaft. The

rear speed sensor

is mounted in the caliper adapter plate (rear disc only) and the rear tone wheel is an integral part of the rear rotor hub. The

front wheel speed sensor

air gap is NOT adjustable. The correct front wheel speed sensor air gap is from

0.40mm to 1.3mm. (0.016" to 0.051")

. Preferred rear sensor air gap for

drum brake system

s is

1.1mm (0.043")

. Acceptable air gap range is 0.92mm to 1.275mm (0.036" to 0.050"). All wheel speed sensors have a resistance between

900 and 1300 ohms

.
Correct antilock. system operation is dependent on tone wheel speed signals from the wheel speed signals from the wheel speed sensors. The vehicle's wheels and tires should all be the same size and type to generate accurate signals. In addition, the tires -should be inflated to the recommended pressures for optimum system operation. Variations in wheel and tire size or significant variations in inflation pressure can produce inaccurate wheel speed signals; however, the system will continue to function when using the mini-spare. When driven over rough road surfaces, the rear wheel speed sensor, signals may be erratic and cause a false trouble code.

G (Acceleration) Switch:

The CAB monitors the

acceleration switch

at all times. The switch assembly contains three mercury switches that monitor vehicle deceleration rates

(G-force). Sudden, rapid changes in vehicle and wheel deceleration rate trigger the switch, sending a signal to the CAB. The switch assembly provides three deceleration rates; two for forward braking and one for rearward braking.

Connector Views (itype_47)

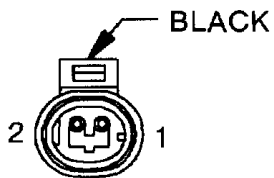

LEFT FRONT WHEEL SPEED

LEFT FRONT WHEEL SPEED SENSOR - BLACK 2 WAY		
CAV	CIRCUIT	FUNCTION
1	B8 18RD/DB	LEFT FRONT WHEEL SPEED SENSOR (-)
2	B9 18RD	LEFT FRONT WHEEL SPEED SENSOR (+)

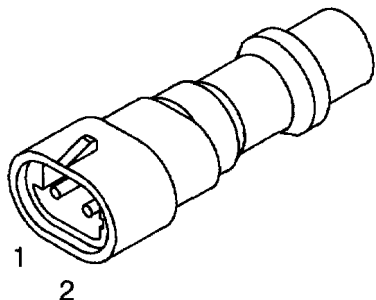

LEFT FRONT WHEEL SPEED SENSOR CONNECTOR (SENSOR SIDE)

LEFT FRONT WHEEL SPEED SENSOR (SENSOR SIDE)		
CAV	CIRCUIT	FUNCTION
1	RD/DB	LEFT FRONT WHEEL SPEED SENSOR (-)
2	RD	LEFT FRONT WHEEL SPEED SENSOR (+)

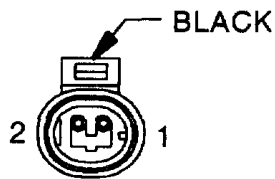

LEFT REAR WHEEL SPEED SENSOR

LEFT REAR WHEEL SPEED SENSOR - BLACK 2 WAY		
CAV	CIRCUIT	FUNCTION
1	B3 18LG/DB	LEFT REAR WHEEL SPEED SENSOR (-)
2	B4 18LG	LEFT REAR WHEEL SPEED SENSOR (+)

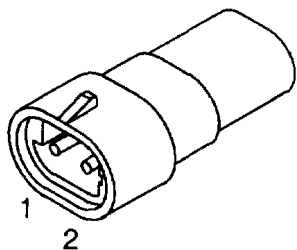

LEFT REAR WHEEL SPEED SENSOR CONNECTOR (SENSOR SIDE)

LEFT REAR WHEEL SPEED SENSOR (SENSOR SIDE)		
CAV	CIRCUIT	FUNCTION
1	LG/DB	LEFT REAR WHEEL SPEED SENSOR (-)
2	LG	LEFT REAR WHEEL SPEED SENSOR (+)

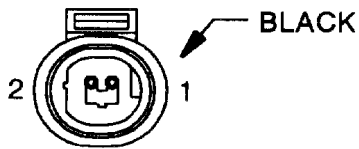

**RIGHT FRONT
WHEEL SPEED
SENSOR**

RIGHT FRONT WHEEL SPEED SENSOR - BLACK 2 WAY		
CAV	CIRCUIT	FUNCTION
1	B6 18WT/DB	RIGHT FRONT WHEEL SPEED SENSOR (-)
2	B7 18WT	RIGHT FRONT WHEEL SPEED SENSOR (+)

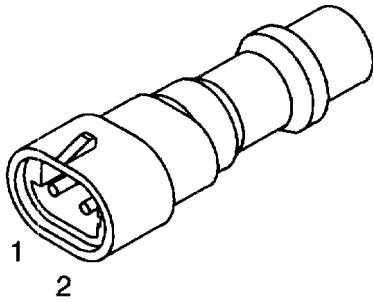

**RIGHT FRONT
WHEEL SPEED
SENSOR
CONNECTOR
(SENSOR SIDE)**

RIGHT FRONT WHEEL SPEED SENSOR (SENSOR SIDE)		
CAV	CIRCUIT	FUNCTION
1	WT/DB	RIGHT FRONT WHEEL SPEED SENSOR (-)
2	WT	RIGHT FRONT WHEEL SPEED SENSOR (+)

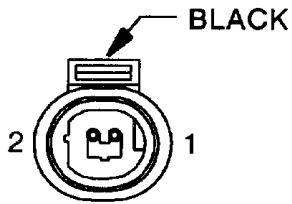

**RIGHT REAR
WHEEL SPEED
SENSOR**

RIGHT REAR WHEEL SPEED SENSOR - BLACK 2 WAY		
CAV	CIRCUIT	FUNCTION
1	B1 18YL/DB	RIGHT REAR WHEEL SPEED SENSOR (-)
2	B2 18YL	RIGHT REAR WHEEL SPEED SENSOR (+)

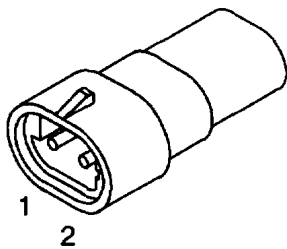

**RIGHT REAR
WHEEL SPEED
SENSOR
CONNECTOR
(SENSOR SIDE)**

RIGHT REAR WHEEL SPEED SENSOR (SENSOR SIDE)		
CAV	CIRCUIT	FUNCTION
1	YL/DB	RIGHT REAR WHEEL SPEED SENSOR (-)
2	18YL	RIGHT REAR WHEEL SPEED SENSOR (+)

FRONT

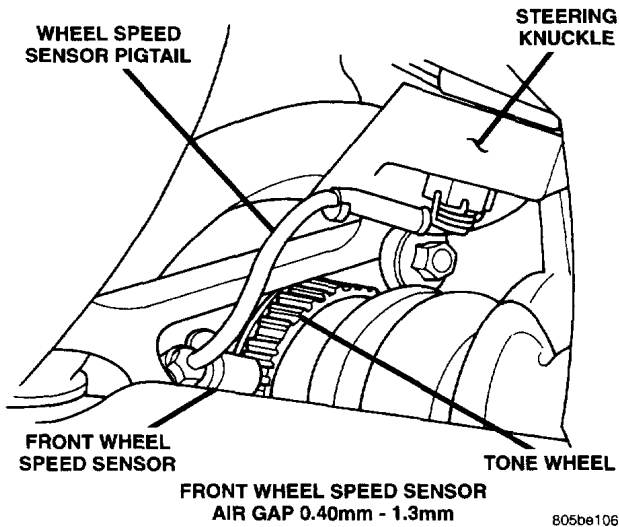

REAR DRUM BRAKES

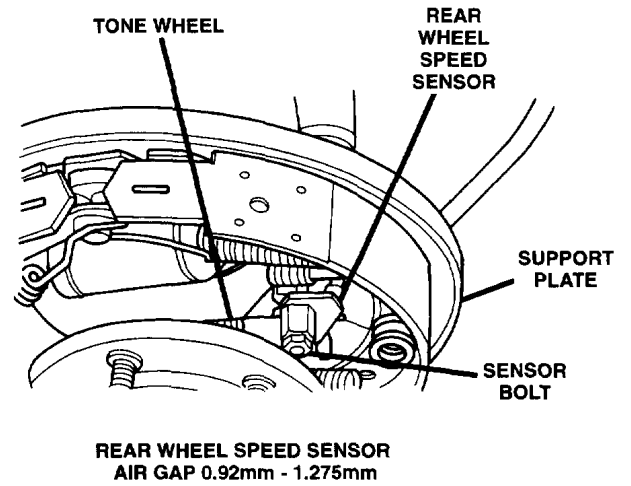

Front Wheel Speed Sensor Connectors (Article 2085327)

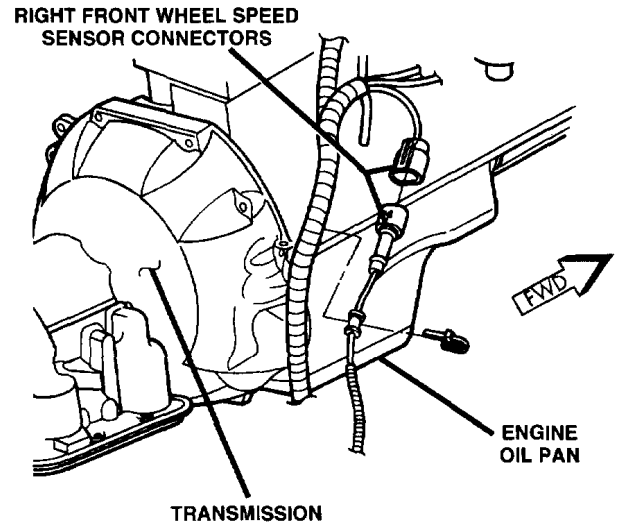
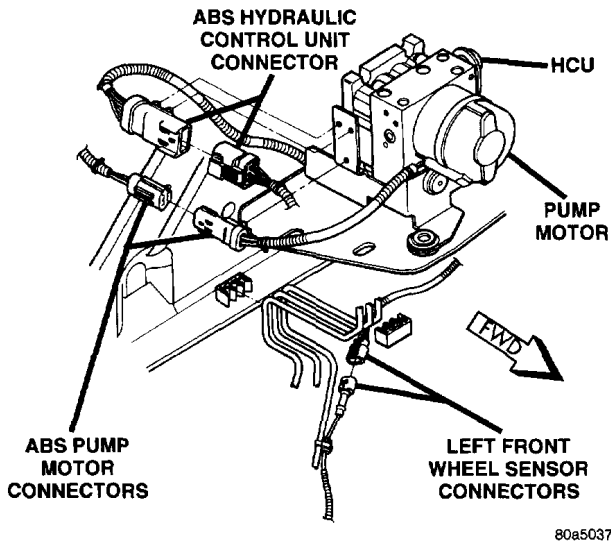

Rear Wheel Speed Sensor Connectors (Article 2085330)

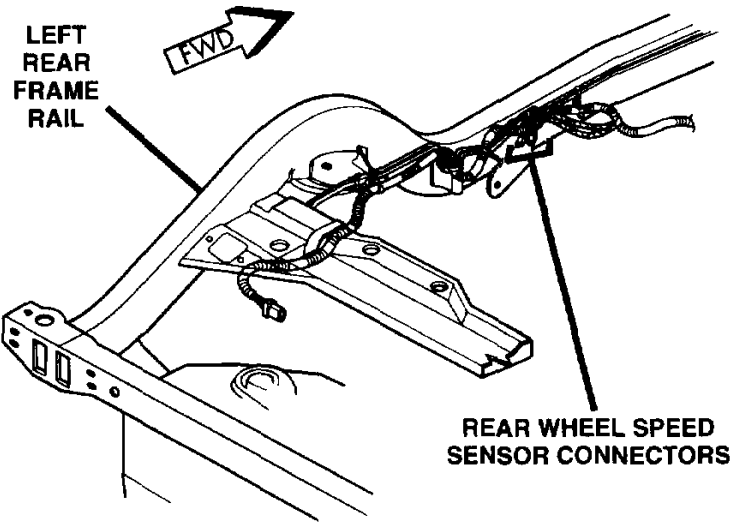

80a50373

Wheel Speed Sensor Replacement (Article 2025497)

- Non Standards
- Front (2025498)
 - Rear (2025499)

Tightening Specifications (Article 2085314)

- Front Mounting Bolt 34 - 50 in.lb
Rear Mounting Bolt 106 - 124 in.lb