

Component Procedures: Auxiliary Power Outlet

Table of Contents

1. Components (itype_392)
2. Electrical (OE) (itype_21)
3. Components (itype_32)
4. Technician Safety Information (itype_15)
5. Component Tests and General Diagnostics (itype_383)

Component Procedures: Auxiliary Power Outlet

Components (itype_392)

DESCRIPTION

An

accessory power outlet

is standard equipment on this model. The

power outlet

is installed in the instrument panel accessory switch bezel, which is located near the bottom of the instrument panel center bezel area, next to the ash receiver. A plastic cap snaps into the power outlet base when the power outlet is not in use. A cigar lighter that fits into the power outlet is a dealer-installed option.

The cigar lighter/power outlet base is serviced only as a part of the accessory switch bezel unit. If the base is faulty or damaged, the accessory switch bezel unit must be replaced. The cigar lighter knob and heating element unit is available for service. This component cannot be repaired and, if faulty or damaged, it must be replaced.

OPERATION

The cigar lighter/power outlet base or receptacle shell is connected to ground

, and an insulated contact in the bottom of the shell is connected to battery

current. The power outlet receives battery voltage from a fuse in the Power Distribution Center

(

PDC

)

through the

accessory relay

only when the

ignition switch

is in the Accessory or On positions. Refer to Accessory Relay in the Instrument Panel, Gauges and Warning Indicators/Cigarette Lighter/Cigarette Lighter Relay/Description and Operation for more information on this component.

The cigar lighter knob and heating element are encased within a spring-loaded housing, which also features a sliding protective heat shield. When the knob and heating element are inserted in the receptacle shell, the heating element resistor coil is grounded through its housing to the receptacle shell. If the cigar lighter knob is pushed inward, the heat shield slides up toward the knob exposing the heating element, and the heating element extends from the housing toward the insulated contact in the bottom of the receptacle shell.

Two small spring-clip retainers are located on either side of the insulated contact inside the bottom of the receptacle shell. These clips engage and hold the heating element of the dealer-installed cigar lighter against the insulated contact long enough for the resistor coil to heat up. When the heating element is engaged with the contact, battery current can flow through the resistor coil to ground, causing the resistor coil to heat.

When the resistor coil becomes sufficiently heated, excess heat radiates from the heating element causing the spring-clips to expand. Once the spring-clips expand far enough to release the heating element, the spring-loaded housing forces the knob and heating element to pop back outward to their relaxed position. When the cigar lighter knob and element are pulled out of the receptacle shell, the protective heat shield slides downward on the housing so that the heating element is recessed and shielded around its circumference for safety.

Electrical (OE) (itype_21)

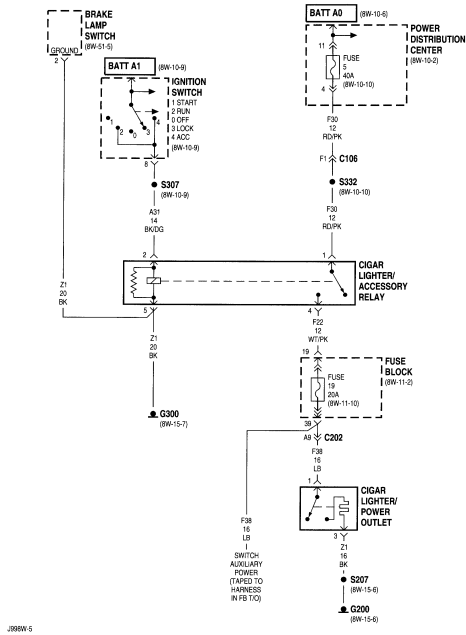

J98W 6

TJ004102

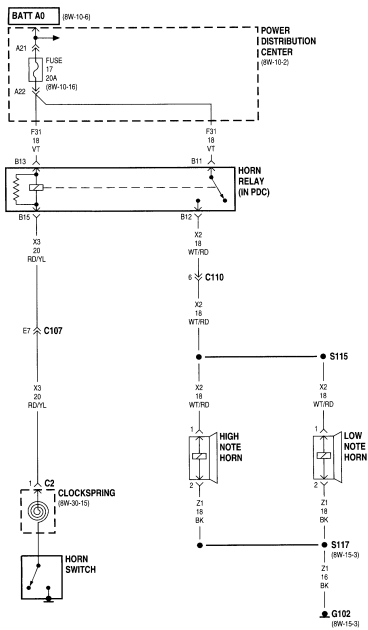

TJ004103

J98W 6

Components (itype_32)

The power outlet is installed in the instrument panel accessory switch bezel, which is located near the bottom of the instrument panel center bezel area, next to the ash receiver.

Technician Safety Information (itype_15)

WARNING: ON VEHICLES EQUIPPED WITH AIRBAGS, REFER TO RESTRAINT SYSTEMS / AIRBAG SYSTEMS BEFORE ATTEMPTING ANY STEERING WHEEL, STEERING COLUMN, OR INSTRUMENT PANEL COMPONENT DIAGNOSIS OR SERVICE. FAILURE TO TAKE THE PROPER PRECAUTIONS COULD RESULT IN ACCIDENTAL AIRBAG DEPLOYMENT AND POSSIBLE PERSONAL INJURY

Component Tests and General Diagnostics (itype_383)

WARNING: ON VEHICLES EQUIPPED WITH AIR-BAGS, REFER TO AIRBAG AND SEAT BELTS/AIR BAGS BEFORE ATTEMPTING ANY STEERING WHEEL, STEERING COLUMN, OR INSTRUMENT PANEL COMPONENT DIAGNOSIS OR SERVICE. FAILURE TO TAKE THE PROPER PRECAUTIONS COULD RESULT IN ACCIDENTAL AIR-BAG DEPLOYMENT AND POSSIBLE PERSONAL INJURY

1. Remove the protective cap or the cigar lighter knob and element from the cigar lighter/power outlet receptacle shell. Check for continuity between the inside circumference of the cigar lighter/power outlet receptacle shell and a good ground.
. there should be continuity. If OK, go to Step 2. If not OK, go to Step 3.
2. Turn the ignition switch to the On position. Check for battery voltage at the insulated contact located at the back of the cigar lighter/power outlet receptacle shell. If OK, replace the faulty cigar lighter knob and element. If not OK, go to Step 3.
3. Turn the ignition switch to the Off position. Disconnect and isolate the battery negative cable. Remove the instrument panel accessory switch bezel. Check for continuity between the ground circuit cavity of the cigar lighter/power outlet wire harness connector and a good ground. There should be continuity. If OK, go to Step 4. If not OK, repair the open ground circuit to ground as required.
4. Connect the battery negative cable. Turn the ignition switch to the Accessory or On positions. Check for battery voltage at the accessory relay output circuit cavity of the cigar lighter/power outlet wire harness connector. If OK, replace the faulty accessory switch bezel unit. If not OK, refer to Accessory Relay in the Instrument Panel, Gauges and Warning Indicators/Cigarette Lighter/Cigarette Lighter Relay/Diagnosis and Testing for further diagnosis.