

Component Procedures: Ignition Switch

Table of Contents

1. Parts and Labor (itype_189)
2. Components (itype_392)
3. Connector Views (itype_47)
4. Components (itype_32)
5. Procedures (itype_376)
6. Technician Safety Information (itype_15)
7. Mechanical (including Torque) (itype_28)
8. Component Tests and General Diagnostics (itype_383)

Component Procedures: Ignition Switch

Parts and Labor (itype_189)

Parts

Qualifier	Part #	Name	Price	Note
Ignition Switch	4565326	Ignition Switch	234.00	

Labor

Operation	Qualifier Path	Skill	Std Hrs	Wty Hrs
Replace	Ignition Switch, R&R	B	0.4	0.3

Components (itype_392)

IGNITION SWITCH

AND KEY

LOCK CYLINDER

The

ignition sw

itch is located on the steering column. The Key-In-Switch is located in the ignition switch module. For electrical diagnosis of the Key-In-Switch, refer to Chime/Buzzer Warning Systems.

On vehicles equipped with an automatic transmission, a cable connects an interlock device within the steering column assembly to the transmission floor shift lever. This interlock device is used to lock the transmission shifter in the PARK position when the key is in the LOCKED or ACCESSORY position. The interlock device is not serviceable. If repair is necessary, the steering column assembly must be replaced. The shifter interlock cable

can

be adjusted or replaced.

On vehicles equipped with a manual transmission, a lever is located on the steering column behind the ignition key lock cylinder. The lever must be operated to allow rotation of the ignition key lock cylinder. The lever mechanism is not serviced separately. If repair is necessary, the steering column assembly must be replaced.

KEY-IN IGNITION SWITCH

The key-in ignition switch is integral to the ignition switch, which is mounted on the left side of the steering column, opposite the

ignition lock cylinder

. It closes a path to

ground

for the instrument cluster chime warning circuitry when the ignition key is inserted in the ignition lock cylinder and the

driver door jamb switch

is closed (driver door is open). The key-in ignition switch opens the ground path when the key is removed from the ignition lock cylinder.

The key-in ignition switch cannot be repaired and, if faulty or damaged, the entire ignition switch must be replaced. Refer to

Ignition System

s for the service procedures.

Connector Views (itype_47)

IGNITION SWITCH - GRAY 10 WAY

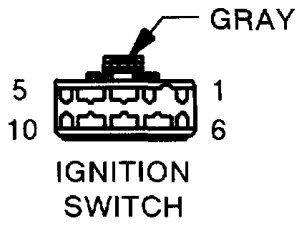

CAV	CIRCUIT	FUNCTION
1	Z1 16BK	GROUND
2	G9 12PK/BK	RED BRAKE WARNING INDICATOR DRIVER
3	A2 12PK/BK	FUSED B(+)
4	A22 12BK/OR	IGNITION SWITCH OUTPUT (RUN)
5	-	-
6	-	-
7	A1 14RD	FUSED B(+)
8	A31 14BK/DG	IGNITION SWITCH OUTPUT (RUN-ACC)
9	A21 14DB	IGNITION SWITCH OUTPUT (ST-RUN)
10	A41 14YL	IGNITION SWITCH OUTPUT (ST)

Components (itype_32)

The ignition switch is located on the steering column.

Procedures (itype_376)

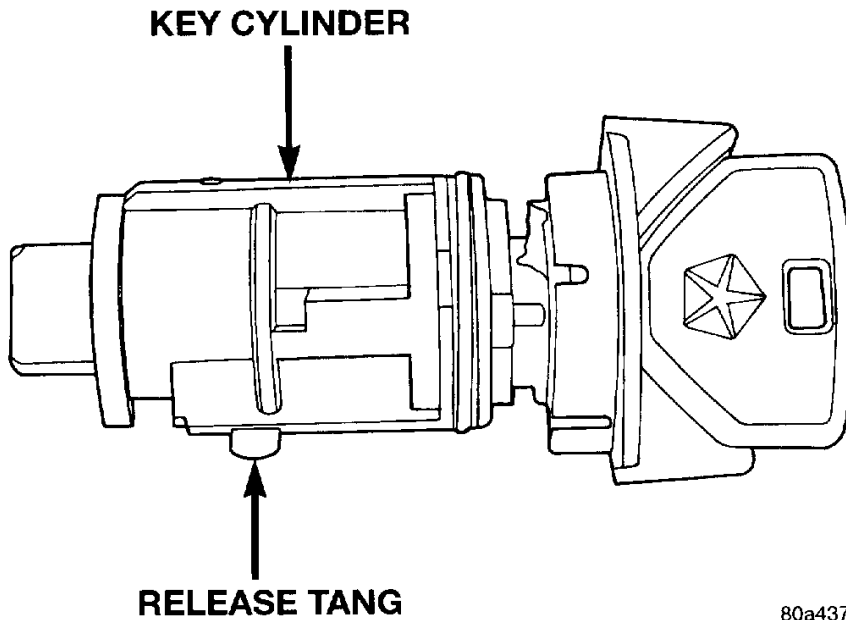

80a43756

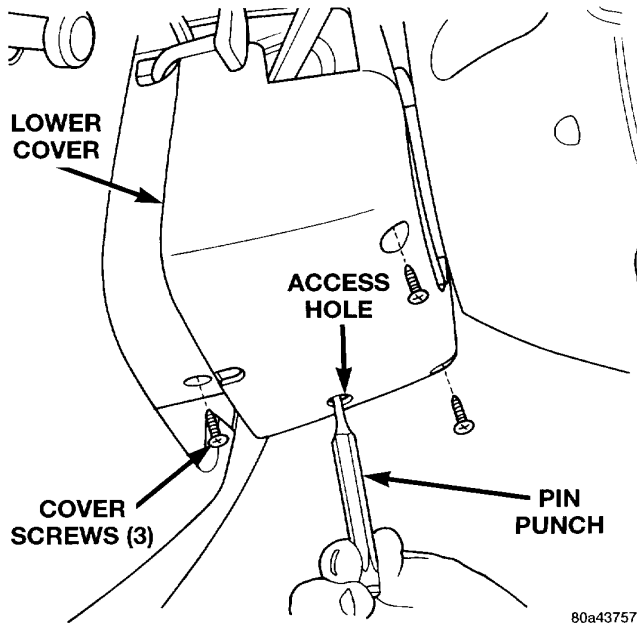

80a43757

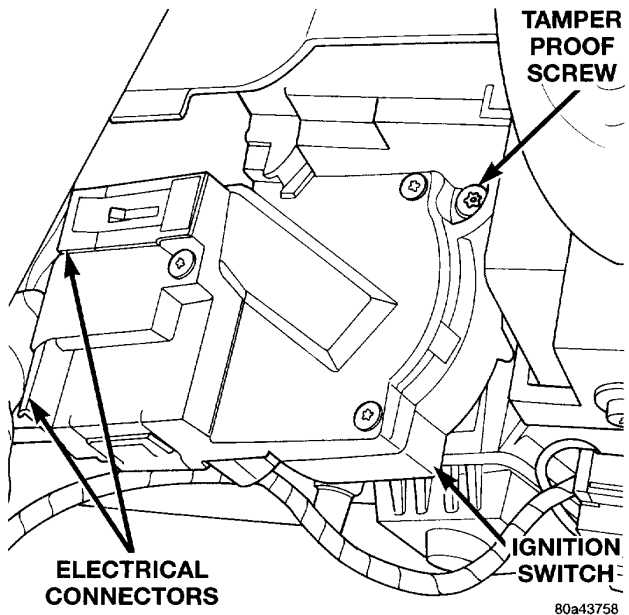

80a43758

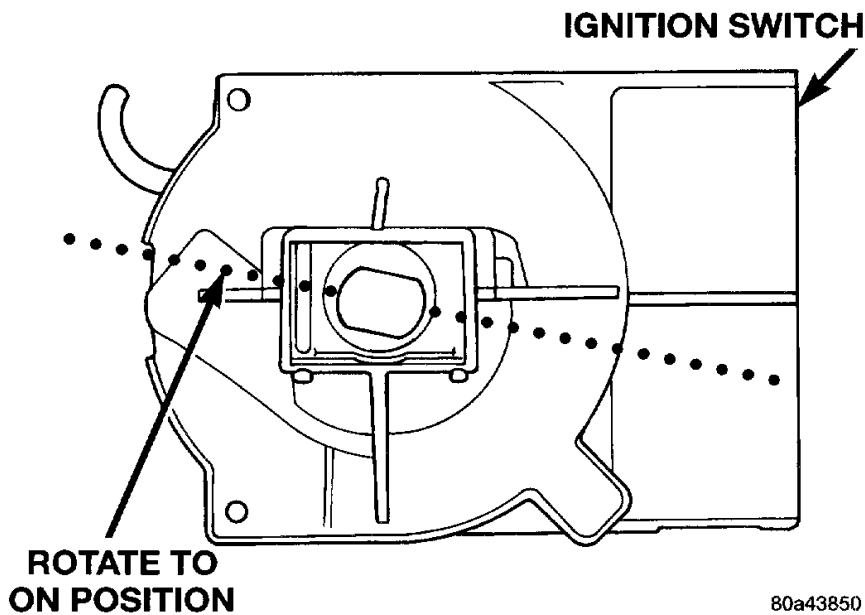
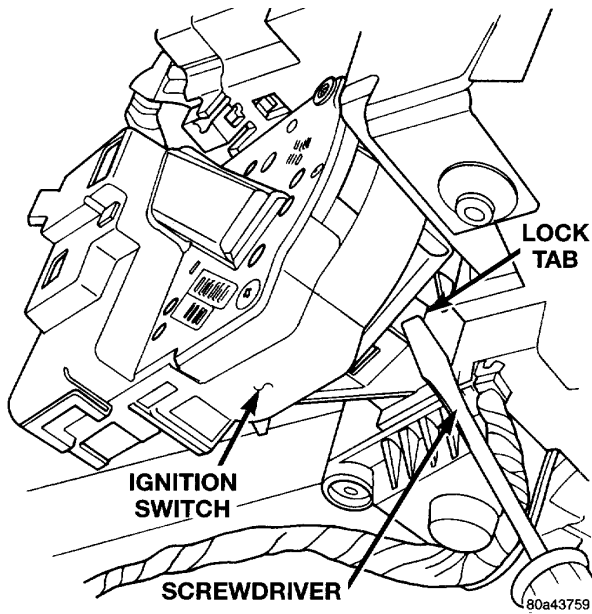

Technician Safety Information (itype_15)

WARNING: ON VEHICLES EQUIPPED WITH AIR-BAGS, REFER TO AIRBAG AND SEAT BELTS/AIR BAGS BEFORE ATTEMPTING ANY STEERING WHEEL, STEERING COLUMN, OR INSTRUMENT PANEL COMPONENT DIAGNOSIS OR SERVICE. FAILURE TO TAKE THE PROPER PRECAUTIONS COULD RESULT IN ACCIDENTAL AIR-BAG DEPLOYMENT AND POSSIBLE PERSONAL INJURY

Mechanical (including Torque) (itype_28)

Ignition Switch Tamper Proof Screw 3 Nm

Component Tests and General Diagnostics (itype_383)

WARNING: ON VEHICLES EQUIPPED WITH AIR-BAGS, REFER TO AIRBAG AND SEAT BELTS/AIR BAGS BEFORE ATTEMPTING ANY STEERING WHEEL, STEERING COLUMN, OR INSTRUMENT PANEL COMPONENT DIAGNOSIS OR SERVICE. FAILURE TO TAKE THE PROPER PRECAUTIONS COULD RESULT IN ACCIDENTAL AIR-BAG DEPLOYMENT AND POSSIBLE PERSONAL INJURY

1. Disconnect and isolate the battery negative cable. Remove the steering column shrouds. Refer to

Ignition System

Follow the procedures. Unplug the key-in ignition switch wire harness connector from the ignition switch.

2. Check for continuity between the key-in switch sense circuit and the left front door jamb switch sense circuit terminals of the key-in ignition switch. There should be continuity with the key in the ignition lock cylinder, and no continuity with the key removed from the ignition lock cylinder. If OK, go to Step 3. If not OK, replace the faulty ignition switch assembly.

3. Check for continuity between the left front door jamb switch sense circuit cavity of the key-in ignition switch wire harness connector and a good ground. There should be continuity with the driver door open, and no continuity with the driver door closed. If OK, see the diagnosis for Instrument Cluster. If not OK, repair the circuit to the driver door jamb switch as required.