

Component Procedures: Evaporative Emission Control Canister

Table of Contents

1. Parts and Labor (itype_189)
2. Components (itype_392)
3. Components (itype_32)
4. Procedures (itype_376)
5. Mechanical (including Torque) (itype_28)

Component Procedures: Evaporative Emission Control Canister

Parts and Labor (itype_189)

Parts

Qualifier	Part #	Name	Price	Note
Vapor Canister	53031904AB	Vapor Canister	0.00	

Labor

Operation	Qualifier Path	Skill	Std Hrs	Wty Hrs
Replace	Vapor Canister, R&R	C	0.6	0.5

Components (itype_392)

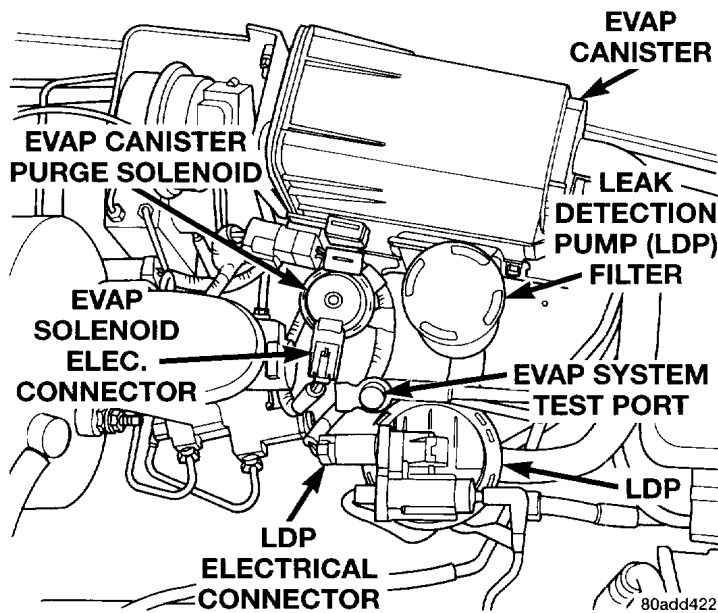

Components (itype_32)

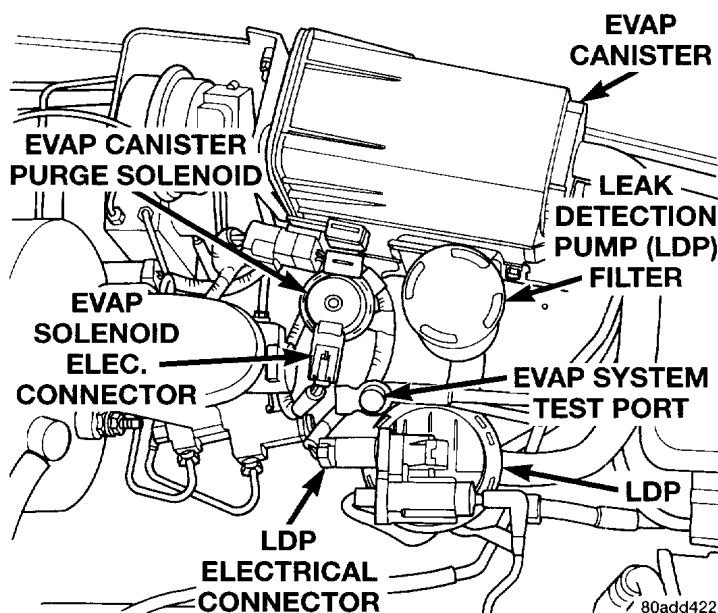

Procedures (itype_376)

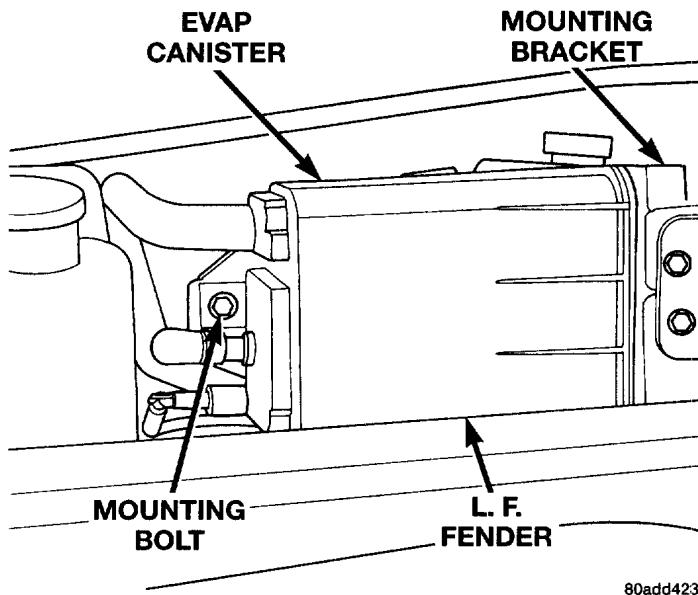
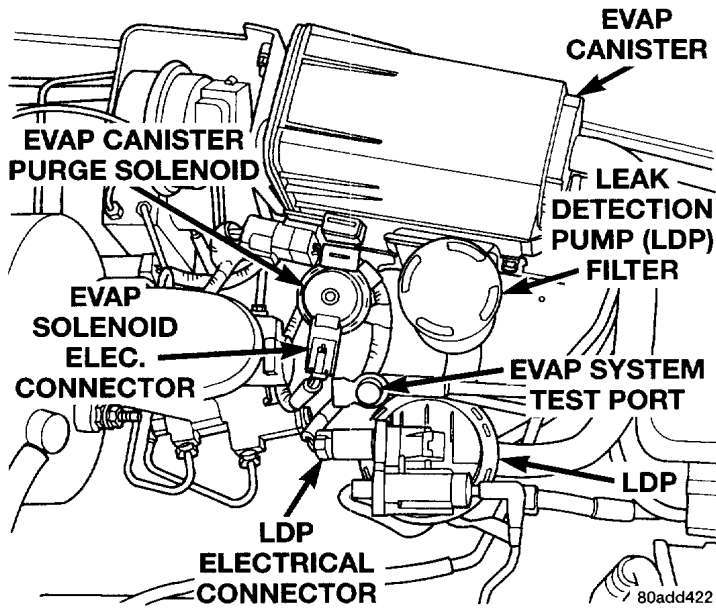

Mechanical (including Torque) (itype_28)

EVAP Canister Bolt 9 Nm