

Component Procedures: Canister Purge Solenoid

Table of Contents

1. Parts and Labor (itype_189)
2. Components (itype_392)
3. Connector Views (itype_47)
4. Components (itype_32)
5. Procedures (itype_376)

Component Procedures: Canister Purge Solenoid

Parts and Labor (itype_189)

Parts

Qualifier	Part #	Name	Price	Note
Purge Solenoid	4669475AB	Vapor Canister Compone?	140.00	

Labor

Operation	Qualifier Path	Skill	Std Hrs	Wty Hrs
Replace	Purge Solenoid, R&R	B	0.4	0.2

Components (itype_392)

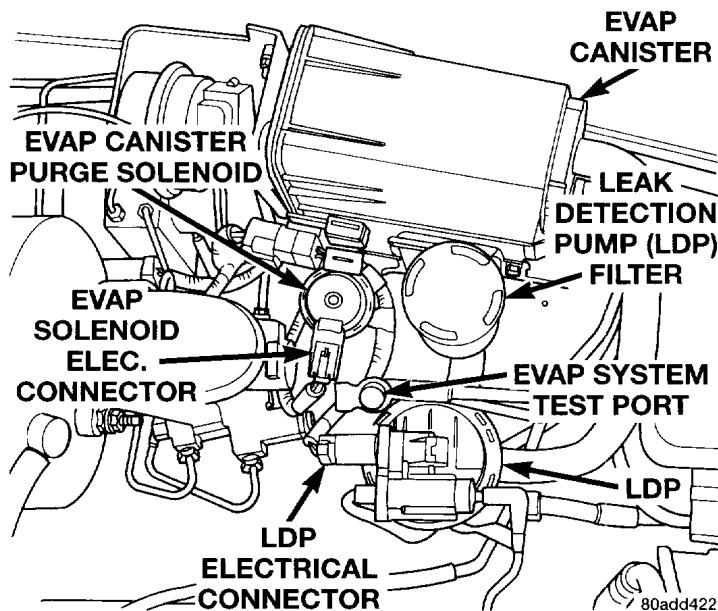

Connector Views (itype_47)

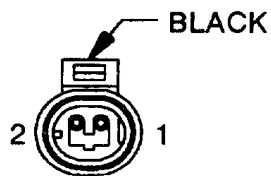

DUTY CYCLE EVAP/PURGE SOLENOID

DUTY CYCLE EVAP/PURGE SOLENOID - BLACK 2 WAY

CAV	CIRCUIT	FUNCTION
1	K52 20PK/BK	DUTY CYCLE EVAP/PURGE SOLENOID CONTROL
2	F12 20RD/LG	FUSED IGNITION SWITCH OUTPUT (ST-RUN)

Components (itype_32)

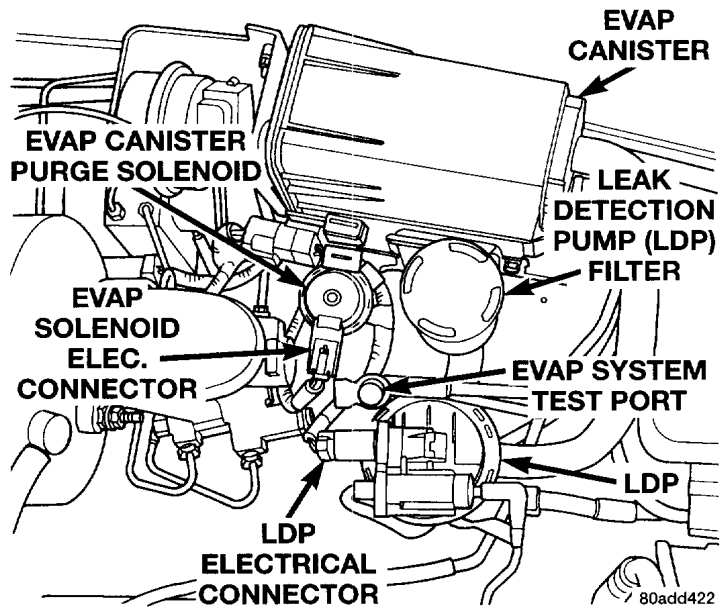

Procedures (itype_376)

