

# **Component Procedures: Instrument Panel, Gauges and Warning Indicators**

## **Table of Contents**

1. Instrument Cluster (Article 10174)
2. Warning Systems (Article 12037)
3. All Technical Service Bulletins (itype\_100)
4. Customer Interest Bulletins (itype\_109)
5. Erratic Operation (itype\_132)
6. Loose (itype\_150)
7. New / Updated Parts (itype\_117)
8. Safety (itype\_107)

# Component Procedures: Instrument Panel, Gauges and Warning Indicators

## Instrument Cluster (Article 10174)

### Instrument Cluster

Interactive Color (Non OE) diagrams for model years 2001 and older use a universal ground location diagram.

[Click here for the diagram.](#)

Page 1 of 1

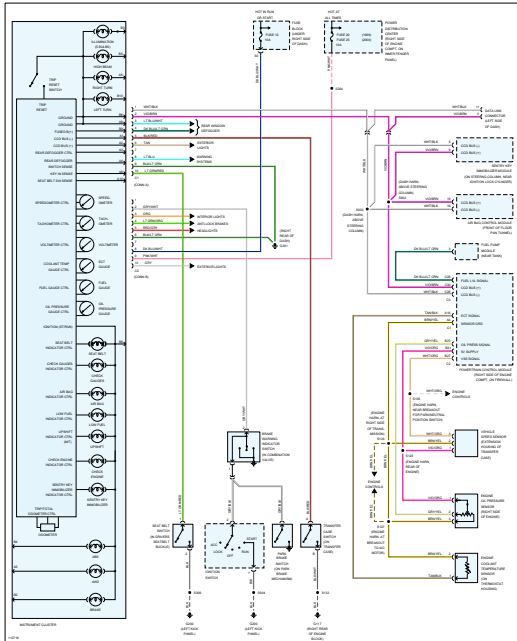

## Warning Systems (Article 12037)

### Warning Systems

Interactive Color (Non OE) diagrams for model years 2001 and older use a universal ground location diagram.

[Click here for the diagram.](#)

Page 1 of 1

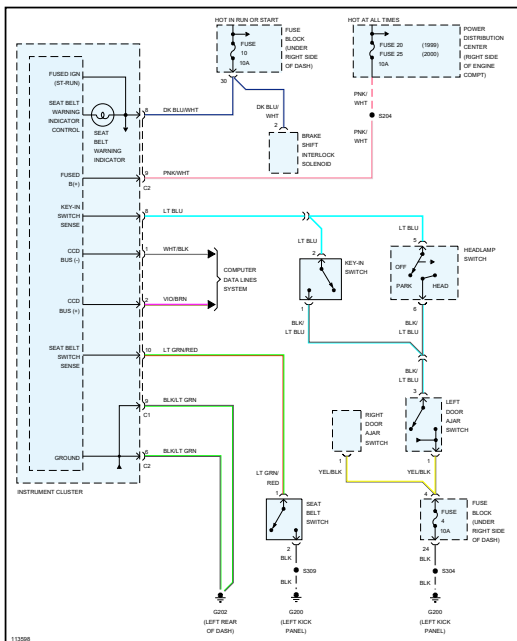

## All Technical Service Bulletins (itype\_100)

### Tsbs

- Recall 99V117000: Instrument Panel Ground Screws Loose (NHTSA99V117000, 1999/05/06)
- Recall - Instrument Panel Ground Screws (830, 1999/05/01)

- Instrument Cluster - Intermittent/Erratic Operation (08-15-99, 1999/05/21)

### **Customer Interest Bulletins (itype\_109)**

Tsbs

- Instrument Cluster - Intermittent/Erratic Operation (08-15-99, 1999/05/21)

### **Erratic Operation (itype\_132)**

Tsbs

- Instrument Cluster - Intermittent/Erratic Operation (08-15-99, 1999/05/21)

### **Loose (itype\_150)**

Tsbs

- Recall 99V117000: Instrument Panel Ground Screws Loose (NHTSA99V117000, 1999/05/06)

### **New / Updated Parts (itype\_117)**

Tsbs

- Instrument Cluster - Intermittent/Erratic Operation (08-15-99, 1999/05/21)

### **Safety (itype\_107)**

Tsbs

- Recall 99V117000: Instrument Panel Ground Screws Loose (NHTSA99V117000, 1999/05/06)

- Recall - Instrument Panel Ground Screws (830, 1999/05/01)