

# Component Procedures: Air Bag

## Table of Contents

1. Parts and Labor (itype\_189)
2. Components (itype\_392)
3. Connector Views (itype\_47)
4. Components (itype\_32)
5. Airbag System Service (Article 2038442)
6. Cleanup Procedure (Article 2038456)
7. Driver Side Airbag Module Replacement (Article 2038436)
8. Driver Side Airbag Module Trim Cover Replacement (Article 2038438)
9. Passenger Side Airbag Door Replacement (Article 2038441)
10. Passenger Side Airbag Module Replacement (Article 2038437)
11. Technician Safety Information (itype\_15)
12. Mechanical (including Torque) (itype\_28)
13. All Technical Service Bulletins (itype\_100)
14. Repair Tips (itype\_110)
15. Component Tests and General Diagnostics (itype\_383)
16. New / Updated Parts (itype\_117)

# Component Procedures: Air Bag

## Parts and Labor (itype\_189)

### Parts

Qualifier	Part #	Name	Price	Note
Passenger Inflator Module	56007282	Air Bag Components, Ai?	0.00	
Driver Inflator Module	5DS48TAZ	Air Bag Components, Ai?	0.00	

### Labor

Operation	Qualifier Path	Skill	Std Hrs	Wty Hrs
Replace	Driver Inflator Module	B	0.3	0.3
Replace	Passenger Inflator Module	B	1.6	1.4

## Components (itype\_392)

### AIRBAG

### SYSTEM

### DESCRIPTION

A dual front airbag system is standard factory-installed safety equipment on this model. The primary passenger restraints in this vehicle are the standard equipment factory-installed seat belts, which require active use by the vehicle occupants. The airbag system is a supplemental passive restraint that was designed and is intended to enhance the protection for the front seat occupants of the vehicle only when used in conjunction with the seat belts. See the owner's manual in the vehicle glove box for more information on the features, use and operation of all of the factory-installed passenger restraints, including the airbag system.

The dual front airbag system consists of the following components:

-

Airbag Control Module

(

ACM

)

- Airbag indicator lamp

- Clockspring

- Driver and passenger side airbag modules (including the airbag inflator

s)

- Driver and passenger side

knee blocker

s

- Passenger side airbag on/off switch

- Wire harness and connections.

It provides complete service information for the ACM, both airbag modules, the clockspring, and the passenger side airbag on/off switch. Complete service information for the other airbag system components can be located as follows:

- Refer to Instrument Cluster in the Instrument Panel Systems/Service and Repair for complete service information for the airbag indicator lamp.

- Refer to

Knee Diverter

/Service and Repair for complete service information on the driver side knee blocker.

- Refer to Body and Frame/Interior Trim/Glove Compartment/Glove Box in the Service and Repair for complete service information on the passenger side knee blocker.

See the proper Diagnostic Procedures to test or diagnose a problem with any component of the airbag system.

### OPERATION

The airbag system electrical circuits are continuously monitored and controlled by a microprocessor and software contained within the Airbag Control Module (ACM). The ACM also contains an impact sensor and a safing sensor, which are monitored by the ACM to determine when an impact occurs that is severe enough to require airbag system protection. When a frontal impact is severe enough, the ACM signals the inflator

units of both airbag modules to deploy the airbags.

An airbag indicator lamp in the instrument cluster lights for about seven seconds

as a bulb test, each time the ignition switch is turned to the On or Start positions. Following the bulb test, the airbag indicator lamp is turned on or off by the ACM to indicate the status of the airbag system. If the airbag indicator lamp comes on at any time other than during the bulb test, it indicates that there is a problem in the airbag system circuits. Such a problem may cause the airbags not to deploy when required, or to deploy when not required.

The driver side airbag module includes an inflatable airbag and an inflator unit behind a trim cover in the hub area of the steering wheel. The passenger side airbag module includes a second

inflatable air- bag and an inflator unit behind an airbag door in the instrument panel above the glove box.

During a frontal vehicle impact, the knee blockers work in concert with properly adjusted seat belts to restrain the driver and front seat passenger in the proper position for an airbag deployment. The knee blockers also work to absorb and distribute the crash energy from the driver and front seat passenger to the structure of the instrument panel. The driver side knee blocker is a stamped metal reinforcement located behind the instrument panel steering column opening cover. The passenger side knee blocker is integral to the glove box door.

**WARNING:**

- THE AIRBAG SYSTEM IS A SENSITIVE, COMPLEX ELECTROMECHANICAL UNIT. BEFORE ATTEMPTING TO DIAGNOSE OR SERVICE ANY AIR-BAG SYSTEM OR RELATED STEERING WHEEL, STEERING COLUMN, OR INSTRUMENT PANEL COMPONENTS YOU MUST FIRST DISCONNECT AND ISOLATE THE BATTERY NEGATIVE (GROUND) CABLE. THEN WAIT TWO MINUTES FOR THE SYSTEM CAPACITOR DISCHARGE BEFORE FURTHER SYSTEM SERVICE. THIS IS THE ONLY SURE WAY TO DISABLE THE AIRBAG SYSTEM. FAILURE TO DO THIS COULD RESULT IN ACCIDENTAL AIR-BAG DEPLOYMENT AND POSSIBLE PERSONAL INJURY.

- THE DRIVER SIDE AIRBAG MODULE INFLATOR ASSEMBLY CONTAINS SODIUM AZIDE AND POTASSIUM NITRATE. THESE MATERIALS ARE POISONOUS AND EXTREMELY FLAMMABLE. CONTACT WITH ACID, WATER, OR HEAVY METALS MAY PRODUCE HARMFUL AND IRRITATING GASES (SODIUM HYDROXIDE IS FORMED IN THE PRESENCE OF MOISTURE) OR COMBUSTIBLE COMPOUNDS. THE PASSENGER AIRBAG MODULE CONTAINS ARGON GAS PRESSURIZED TO OVER 2500 PSI. DO NOT ATTEMPT TO DISMANTLE AN AIRBAG MODULE OR TAMPER WITH ITS INFLATOR. DO NOT PUNCTURE, INCINERATE, OR BRING INTO CONTACT WITH ELECTRICITY. DO NOT STORE AT TEMPERATURES EXCEEDING 93° C (200° F).

- REPLACE AIRBAG SYSTEM COMPONENTS ONLY WITH PARTS SPECIFIED IN THE CHRYSLER MOPAR PARTS CATALOG. SUBSTITUTE PARTS MAY APPEAR INTERCHANGEABLE, BUT INTERNAL DIFFERENCES MAY RESULT IN INFERIOR OCCUPANT PROTECTION.

- THE FASTENERS, SCREWS, AND BOLTS ORIGINALLY USED FOR THE AIRBAG SYSTEM COMPONENTS HAVE SPECIAL COATINGS AND ARE SPECIFICALLY DESIGNED FOR THE AIRBAG SYSTEM. THEY MUST NEVER BE REPLACED WITH ANY SUBSTITUTES. ANY TIME A NEW FASTENER IS NEEDED, REPLACE IT WITH THE CORRECT FASTENERS PROVIDED IN THE SERVICE PACKAGE OR SPECIFIED IN THE CHRYSLER MOPAR PARTS CATALOG.

- WHEN A STEERING COLUMN HAS AN AIRBAG MODULE ATTACHED, NEVER PLACE THE COLUMN ON THE FLOOR OR ANY OTHER SURFACE WITH THE STEERING WHEEL OR AIRBAG MODULE FACE DOWN

#### DRIVER SIDE AIRBAG MODULE

The driver side airbag module protective trim cover is the most visible part of the driver side airbag system.

The driver side airbag module is mounted directly to the steering wheel. Located under the air- bag module trim cover are the horn switch, the folded airbag cushion, and the airbag cushion supporting components. The resistive membrane-type horn switch is secured with heat stakes to the inside surface of the airbag module trim cover, between the trim cover and the folded airbag cushion.

The driver side airbag module cannot be repaired, and must be replaced if deployed or in any way damaged. The driver side airbag module trim cover and the horn switch are available as a unit for service replacement.

The driver side airbag module includes a stamped metal housing to which the cushion and an inflator unit are attached and sealed. The conventional pyrotechnic-type inflator assembly is mounted to studs on the back of the airbag module housing. The inflator seals the hole in the airbag cushion so it can discharge the gas it produces directly into the cushion when supplied with the proper electrical signal. Following an airbag deployment, the airbag cushion quickly deflates by venting this gas towards the instrument panel through the porous fabric material used on the steering wheel side of the airbag cushion.

The protective trim cover is fitted to the front of the airbag module and forms a decorative cover in the center of the steering wheel. The inside of the trim cover has locking blocks molded into it that engage a lip on the airbag module metal housing. Two stamped metal retainers then fit over the inflator mounting studs on the back of the airbag module housing and are engaged in slots on the inside of the cover, securely locking the trim cover into place. The trim cover will split at predetermined breakout lines, then fold back out of the way along with the horn switch upon airbag deployment.

#### PASSENGER SIDE AIRBAG MODULE

The passenger side airbag door on the instrument panel above the glove box is the most visible part of the

passenger side airbag system. Located under the airbag door are the passenger side airbag cushion and the airbag cushion supporting components.

The passenger side airbag module includes a stamped metal housing within which the cushion and inflator are mounted and sealed. The airbag housing has three stamped metal mounting brackets spot welded to it. The mounting brackets at the top and at the lower rear of the airbag module secure the module to the instrument panel armature. The stamped metal mounting bracket at the lower front of the housing secures the passenger side airbag module to two studs on the dash panel, behind the glove box. A plastic end bracket encloses the inboard end of the housing and retains the wire harness connector for the inflator.

Following a passenger side airbag deployment, the passenger side airbag module, the passenger side air-bag door and the instrument panel assembly must be replaced. The passenger side airbag module cannot be repaired, and must be replaced if deployed or in any way damaged. The passenger side airbag door is available as a separate service item.

The hybrid-type inflator assembly includes a small canister of highly compressed argon gas. The inflator seals the hole in the airbag cushion so it can discharge the gas it produces directly into the cushion when supplied with the proper electrical signal. Following an airbag deployment, the airbag cushion quickly deflates by venting this gas through the porous fabric material used on each end panel of the airbag cushion.

The molded plastic passenger side airbag door is secured to the instrument panel at the upper and lower flanges with screws. A stamped metal bracket located on the back side of the airbag door is secured to the instrument panel armature with one screw on each end, and serves as the hinge for the door upon an airbag deployment. The airbag door has predetermined breakout lines concealed beneath its decorative cover. Upon airbag deployment, the airbag door will split at the breakout lines and the door will fold back over the top of the instrument panel, out of the way.

### Connector Views (itype\_47)

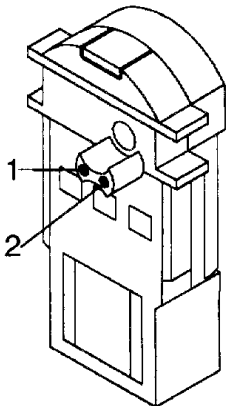

DRIVER AIRBAG SQUIB

**DRIVER AIRBAG SQUIB**

CAV	CIRCUIT	FUNCTION
1	BK/LB	DRIVER AIRBAG LINE 1
2	DG/LB	DRIVER AIRBAG LINE 2

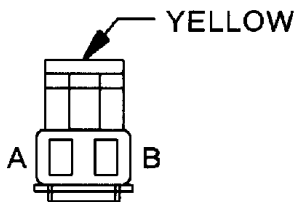

PASSENGER AIRBAG

**PASSENGER AIRBAG - YELLOW 2 WAY**

CAV	CIRCUIT	FUNCTION
A	R44 18DG/YL	PASSENGER AIRBAG LINE 2
B	R42 18BK/YL	PASSENGER AIRBAG LINE 1

### Components (itype\_32)

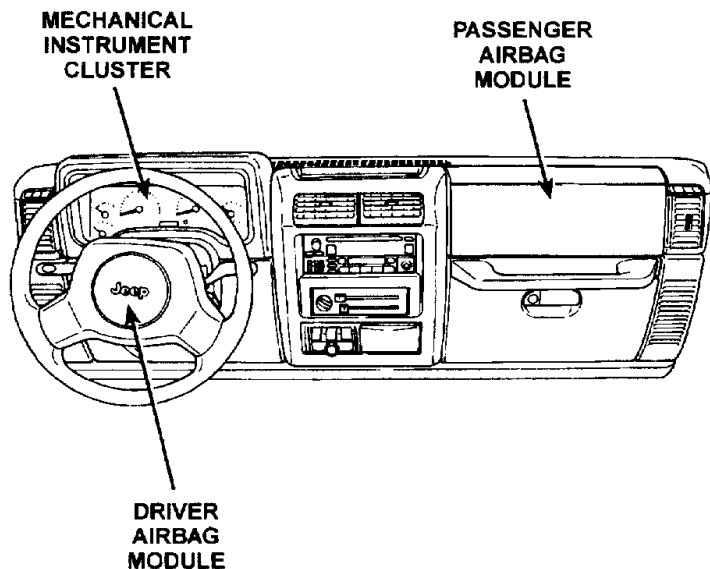

80a48362

## Airbag System Service (Article 2038442)

### Non-deployed

At no time should any source of electricity be permitted near the inflator on the back of an airbag

module. When carrying a non-deployed airbag module, the trim cover or airbag side of the module should be pointed away from the body to minimize injury in the event of an accidental deployment. If the module is placed on a bench or any other surface, the trim cover or airbag side of the module should be face up to minimize movement in the event of an accidental deployment.

In addition, the airbag system should be disarmed whenever any steering wheel, steering column, or instrument panel components require diagnosis or service. Failure to observe this warning could result in accidental airbag deployment and possible personal injury. Refer to Instrument Panel Systems/Service and Repair for additional service procedures on the instrument panel components.

### Disposal Of Non-deployed Airbag Modules

All damaged or faulty and non-deployed driver side or passenger side airbag modules which are replaced on vehicles are to be returned. If an airbag module assembly is faulty or damaged and non-deployed, refer to the parts return list in the current Chrysler Corporation Warranty Policies and Procedures for the proper handling and disposal procedures.

### Deployed

Any vehicle which is to be returned to use after an airbag deployment, must have both airbag modules, the instrument panel assembly, the steering column assembly and the clockspring replaced. These components will be damaged or weakened as a result of an airbag deployment, which may or may not be obvious during a visual inspection, and are not intended for reuse.

Other vehicle components should be closely inspected, but are to be replaced only as required by the extent of the visible damage incurred.

### Storage

An airbag module must be stored in its original, special container until used for service. Also, it must be stored in a clean, dry environment; away from sources of extreme heat, sparks, and high electrical energy. Always place or store an airbag module on a surface with its trim cover or airbag side facing up, to minimize movement in case of an accidental deployment.

## Cleanup Procedure (Article 2038456)

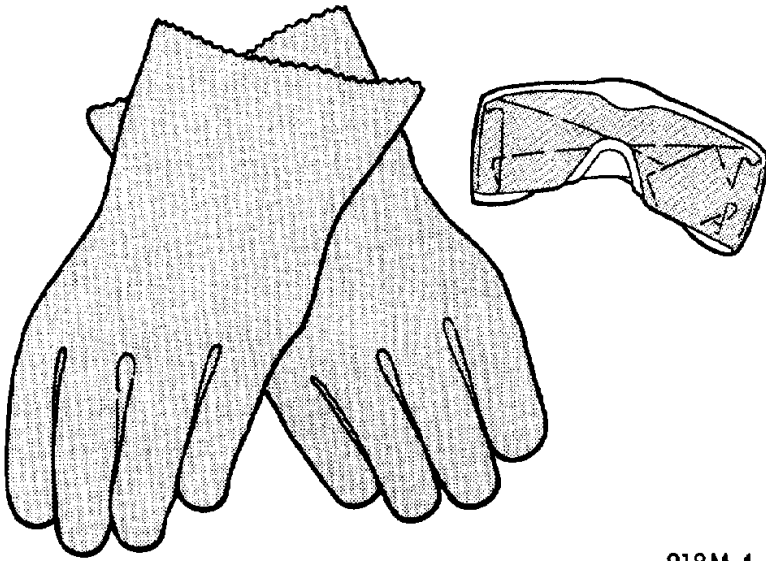

918M-4

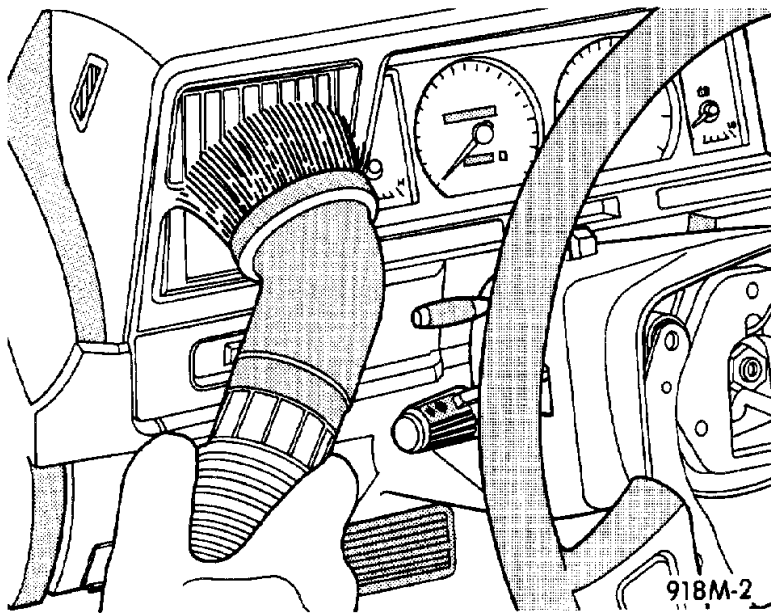

918M-2

**Driver Side Airbag Module Replacement (Article 2038436)**

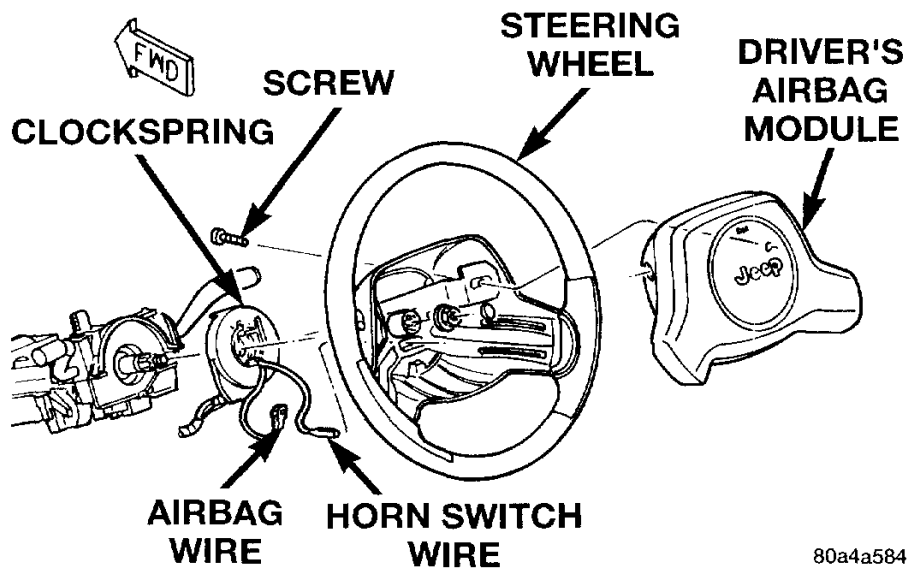

80a4a584

**Driver Side Airbag Module Trim Cover Replacement (Article 2038438)**

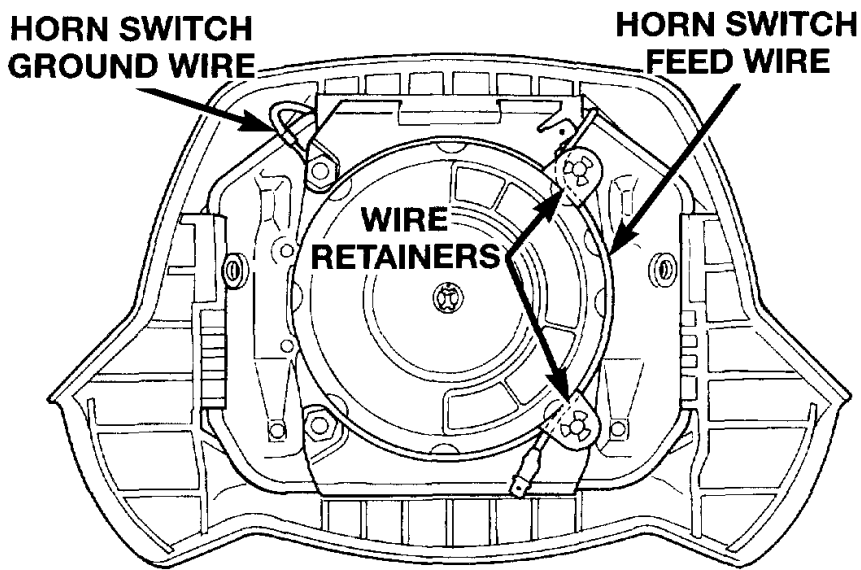

80a4a58b

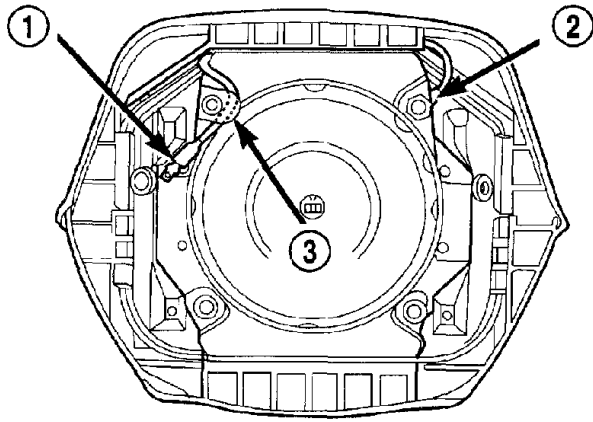

80ab88a3

- 1 - HORN SWITCH FEED WIRE
- 2 - HORN SWITCH GROUND WIRE
- 3 - WIRE RETAINER

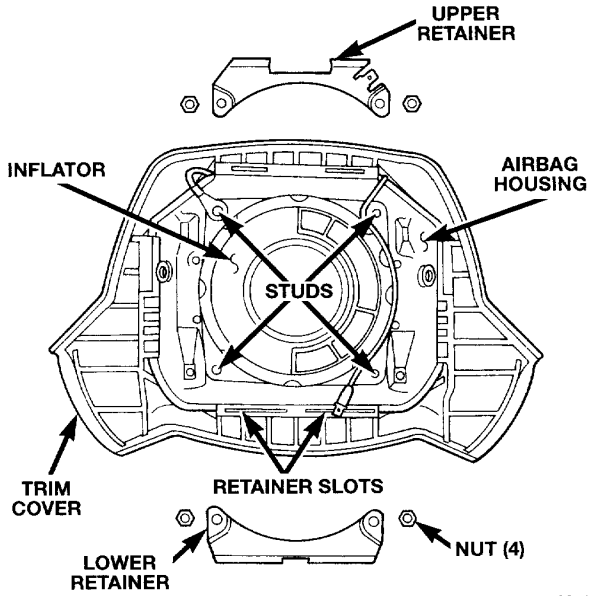

80a4a58c

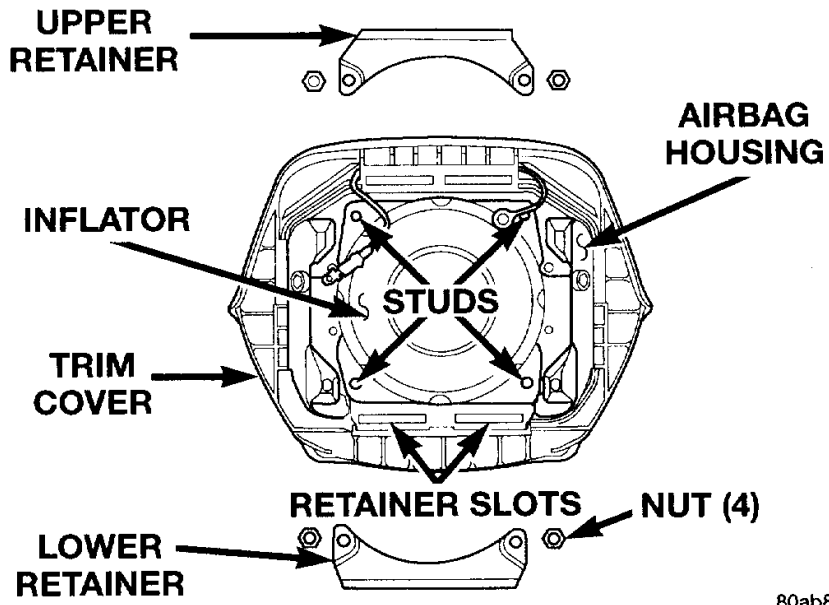

80ab88a4

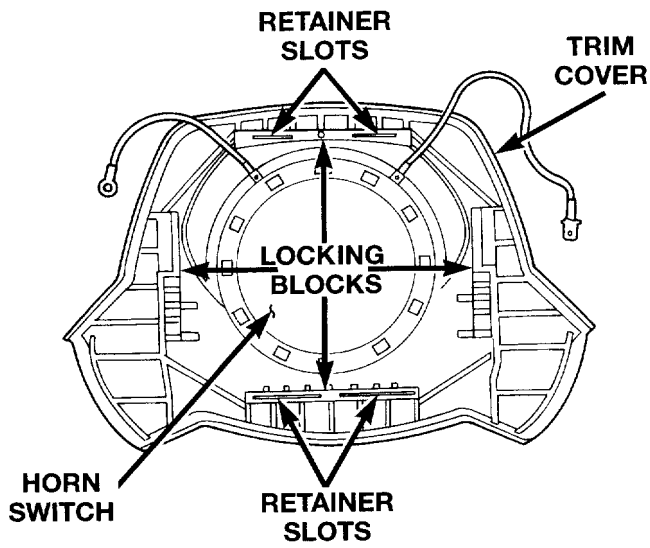

80a4a58d

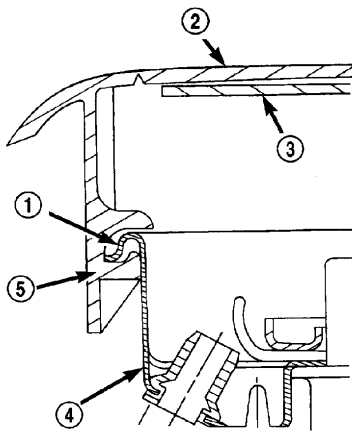
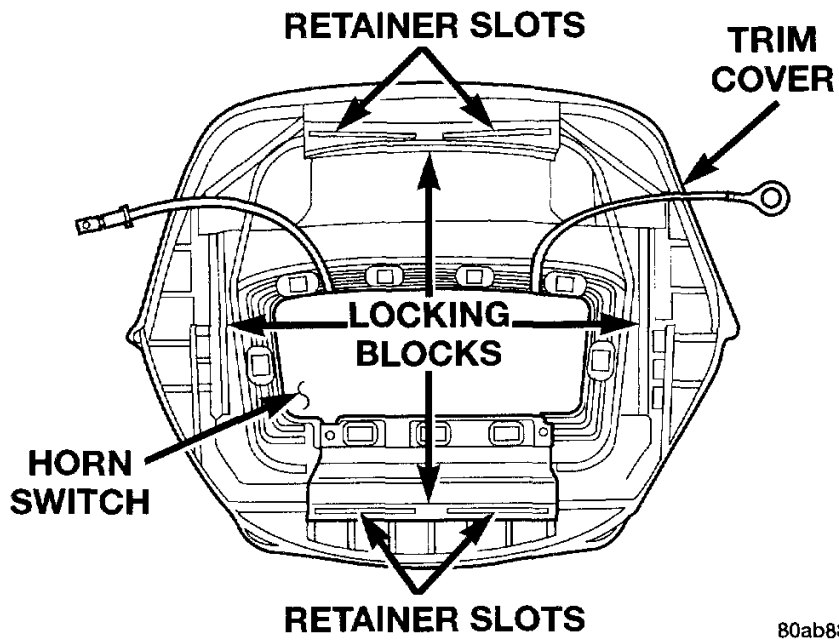

- 1 - LIP
- 2 - TRIM COVER
- 3 - HORN SWITCH
- 4 - AIRBAG HOUSING
- 5 - LOCKING BLOCK

**Passenger Side Airbag Door Replacement (Article 2038441)**

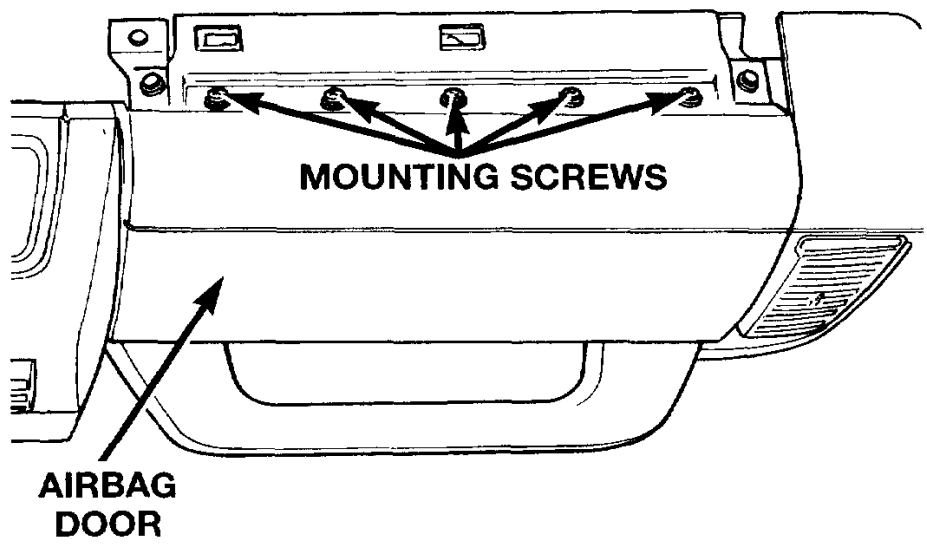

80ae5fab

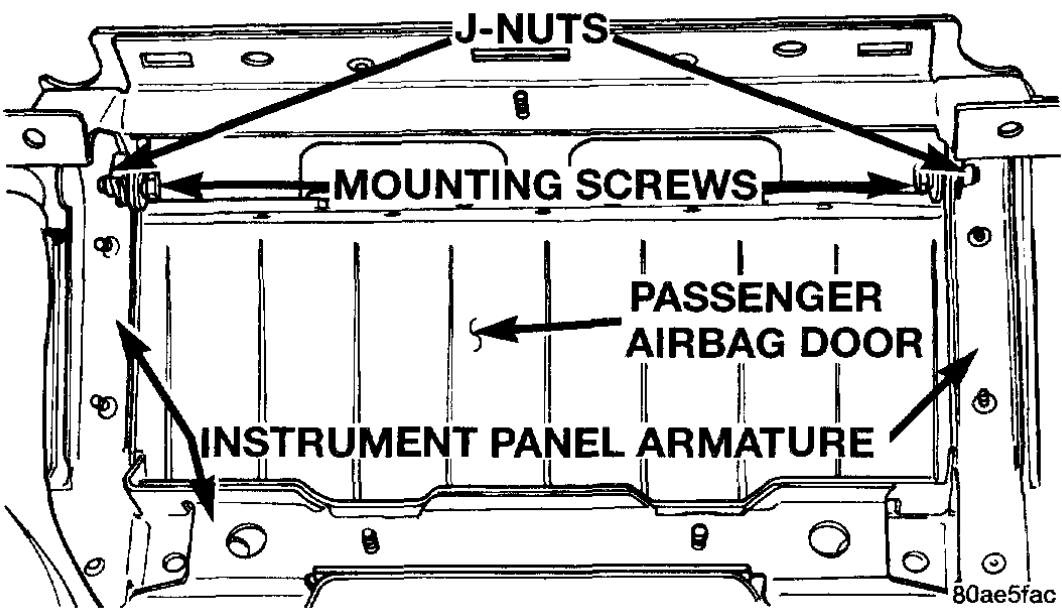

80ae5fac

Passenger Side Airbag Module Replacement (Article 2038437)

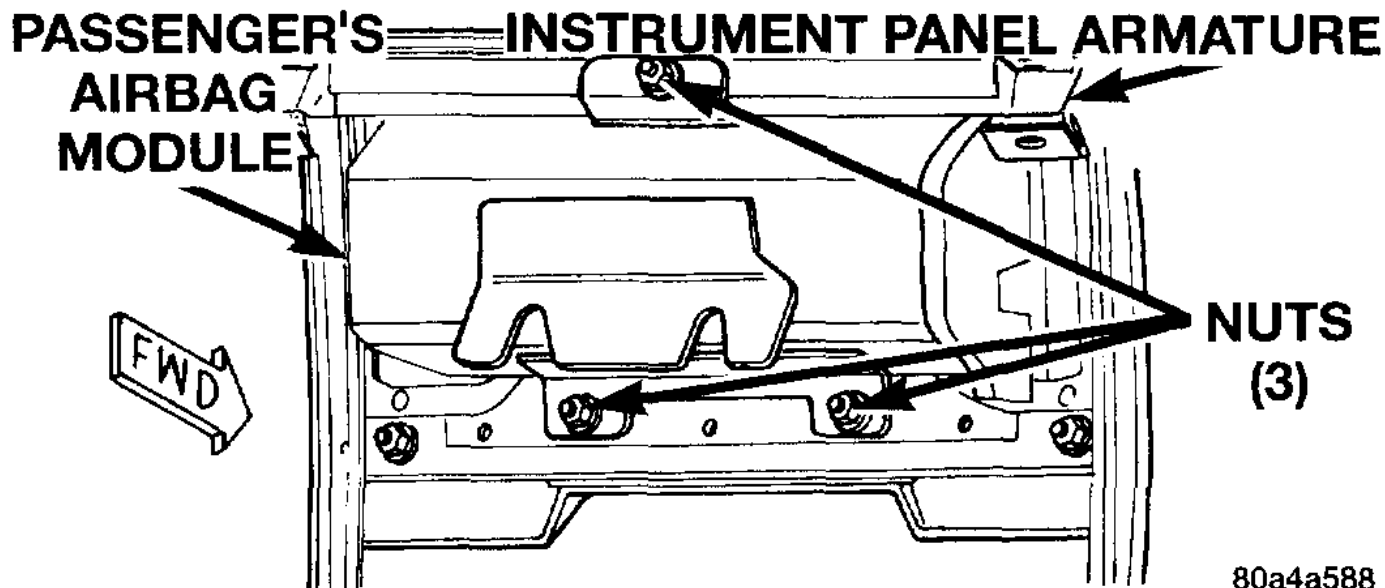

### Technician Safety Information (itype\_15)

#### WARNING:

#### - THE AIRBAG

SYSTEM IS A SENSITIVE, COMPLEX ELECTROMECHANICAL UNIT. BEFORE ATTEMPTING TO DIAGNOSE OR SERVICE ANY AIR-BAG SYSTEM OR RELATED STEERING WHEEL, STEERING COLUMN, OR INSTRUMENT PANEL COMPONENTS YOU MUST FIRST DISCONNECT AND ISOLATE THE BATTERY NEGATIVE (GROUND) CABLE. THEN WAIT TWO MINUTES FOR THE SYSTEM CAPACITOR TO DISCHARGE BEFORE FURTHER SYSTEM SERVICE. THIS IS THE ONLY SURE WAY TO DISABLE THE AIRBAG SYSTEM. FAILURE TO DO THIS COULD RESULT IN ACCIDENTAL AIR-BAG DEPLOYMENT AND POSSIBLE PERSONAL INJURY.

- IF YOU EXPERIENCE SKIN IRRITATION DURING CLEANUP, RUN COOL WATER OVER THE AFFECTED AREA. ALSO, IF YOU EXPERIENCE IRRITATION OF THE NOSE OR THROAT, EXIT THE VEHICLE FOR FRESH AIR UNTIL THE IRRITATION CEASES. IF IRRITATION CONTINUES, SEE A PHYSICIAN.

- WHEN REMOVING A DEPLOYED AIRBAG MODULE, RUBBER GLOVES, EYE PROTECTION, AND A LONG-SLEEVED SHIRT SHOULD BE WORN. THERE MAY BE DEPOSITS ON THE AIRBAG MODULE AND OTHER INTERIOR SURFACES. IN LARGE DOSES, THESE DEPOSITS MAY CAUSE IRRITATION TO THE SKIN AND EYES.

#### - THE DRIVER SIDE AIRBAG MODULE INFLATOR

ASSEMBLY CONTAINS SODIUM AZIDE AND POTASSIUM NITRATE. THESE MATERIALS ARE POISONOUS AND EXTREMELY FLAMMABLE. CONTACT WITH ACID, WATER, OR HEAVY METALS MAY PRODUCE HARMFUL AND IRRITATING GASES (SODIUM HYDROXIDE IS FORMED IN THE PRESENCE OF MOISTURE) OR COMBUSTIBLE COMPOUNDS. THE PASSENGER AIRBAG MODULE CONTAINS ARGON GAS PRESSURIZED TO OVER 2500 PSI. DO NOT ATTEMPT TO DISMANTLE AN AIRBAG MODULE OR TAMPER WITH ITS INFLATOR. DO NOT PUNCTURE, INCINERATE, OR BRING INTO CONTACT WITH ELECTRICITY. DO NOT STORE AT TEMPERATURES EXCEEDING 93° C (200° F).

- REPLACE AIRBAG SYSTEM COMPONENTS ONLY WITH PARTS SPECIFIED IN THE CHRYSLER MOPAR PARTS CATALOG. SUBSTITUTE PARTS MAY APPEAR INTERCHANGEABLE, BUT INTERNAL DIFFERENCES MAY RESULT IN INFERIOR OCCUPANT PROTECTION.

- THE FASTENERS, SCREWS, AND BOLTS ORIGINALLY USED FOR THE AIRBAG SYSTEM COMPONENTS HAVE SPECIAL COATINGS AND ARE SPECIFICALLY DESIGNED FOR THE AIRBAG SYSTEM. THEY MUST NEVER BE REPLACED WITH ANY SUBSTITUTES. ANY TIME A NEW FASTENER IS NEEDED, REPLACE IT WITH THE CORRECT FASTENERS PROVIDED IN THE SERVICE PACKAGE OR SPECIFIED IN THE CHRYSLER MOPAR PARTS CATALOG.

- WHEN A STEERING COLUMN HAS AN AIRBAG MODULE ATTACHED, NEVER PLACE THE COLUMN ON THE FLOOR OR ANY OTHER SURFACE WITH THE STEERING WHEEL OR AIRBAG MODULE FACE DOWN.

- USE EXTREME CARE TO PREVENT ANY FOREIGN MATERIAL FROM ENTERING THE DRIVER SIDE AIRBAG MODULE, OR BECOMING ENTRAPPED BETWEEN THE AIRBAG CUSHION AND THE DRIVER SIDE AIRBAG TRIM COVER. FAILURE TO OBSERVE THIS WARNING COULD RESULT IN OCCUPANT INJURIES UPON AIRBAG DEPLOYMENT.

- THE DRIVER SIDE AIRBAG MODULE TRIM COVER MUST NEVER BE PAINTED. REPLACEMENT TRIM COVERS ARE SERVICED IN THE ORIGINAL COLORS. PAINT MAY CHANGE THE WAY IN WHICH THE MATERIAL OF THE TRIM COVER RESPONDS TO AN AIR BAG

DEPLOYMENT. FAILURE TO OBSERVE THIS WARNING COULD RESULT IN OCCUPANT INJURIES UPON AIRBAG DEPLOYMENT.

- THE HORN SWITCH IS INTEGRAL TO THE AIR-BAG MODULE TRIM COVER. SERVICE OF THIS COMPONENT SHOULD BE PERFORMED

ONLY BY CHRYSLER-TRAINED AND AUTHORIZED DEALER SERVICE TECHNICIANS. FAILURE TO TAKE THE PROPER PRECAUTIONS TO FOLLOW THE PROPER PROCEDURES COULD RESULT IN ACCIDENTAL, INCOMPLETE, OR IMPROPER AIRBAG DEPLOYMENT AND POSSIBLE OCCUPANT INJURIES.

- THE PASSENGER SIDE AIRBAG DOOR MUST NEVER BE PAINTED. REPLACEMENT AIRBAG DOORS ARE SERVICED IN THE ORIGINAL COLORS. PAINT MAY CHANGE THE WAY IN WHICH THE MATERIAL OF THE AIRBAG DOOR RESPONDS TO AN AIRBAG DEPLOYMENT FAILURE TO OBSERVE THIS WARNING COULD RESULT IN OCCUPANT INJURIES UPON AIRBAG DEPLOYMENT

### **Mechanical (including Torque) (itype\_28)**

Tighten the trim cover retainer mounting nuts on the airbag housing studs nuts to 10 Nm (90 in. lbs.)

Tighten the two driver side airbag module mounting screws to 10.2 Nm (90 in. lbs.)

Tighten the three nuts that secure the passenger side airbag module upper and lower mounting brackets to the studs on the instrument panel armature nuts to 12 Nm (105 in. lbs.)

Tighten the two screws that secure the passenger side airbag door bracket to the instrument panel armature screws to

Tighten the five screws that secure the passenger side airbag door lower flange to the instrument panel above the glove box opening screws to 2.2 Nm (20 in. lbs.)

Tighten the five screws that secure the passenger side airbag door upper flange to the top of the instrument panel screws to

### **All Technical Service Bulletins (itype\_100)**

Tsbs

- Airbag/Clock Spring - Service (08-010-01, 2001/05/25)
- Driver Airbag - Trim Cover Service (19-009-01, 2001/10/26)

### **Repair Tips (itype\_110)**

Tsbs

- Airbag/Clock Spring - Service (08-010-01, 2001/05/25)

### **Component Tests and General Diagnostics (itype\_383)**

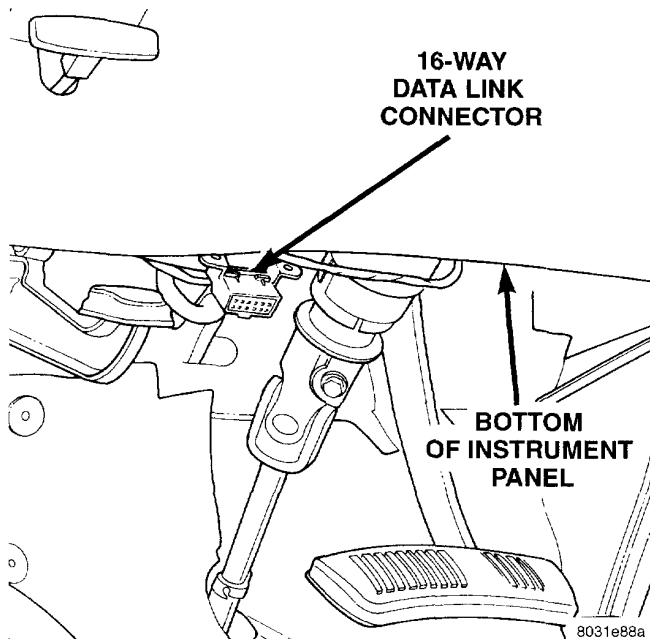

## **New / Updated Parts (itype\_117)**

Tsbs

- Driver Airbag - Trim Cover Service (19-009-01, 2001/10/26)