

Component Procedures: Crankshaft Main Bearing

Table of Contents

1. Parts and Labor (itype_189)
2. Removal and Installation (Article 2036699)
3. Rebuild Specifications (Article 2039310)

Component Procedures: Crankshaft Main Bearing

Parts and Labor (itype_189)

Parts

Qualifier	Part #	Name	Price	Note
Bearings	83500300	25 - Bearings	24.50	Includes: One Standard Upp?
Bearings > No.1-5	83507079	26 - Bearings	8.75	Includes: One Standard Upp?
Bearings > Thrust Bearing > ?	83507084	26 - Bearings	32.95	Includes: One Standard Upp?
Bearings > Thrust Bearing > ?	83507080AB	26 - Bearings	0.00	Includes: One Standard Upp?

Labor

Operation	Qualifier Path	Skill	Std Hrs	Wty Hrs
Replace	Main Bearings > All	B	4.0	2.4
Replace	Main Bearings > All > NOTE > To R&R Oil Pump, ?	B	0.4	0.3
Replace	Main Bearings > One	B	3.0	2.2
Replace	Main Bearings > One > NOTE > To R&R Oil Pump, ?	B	0.4	0.3

Removal and Installation (Article 2036699)

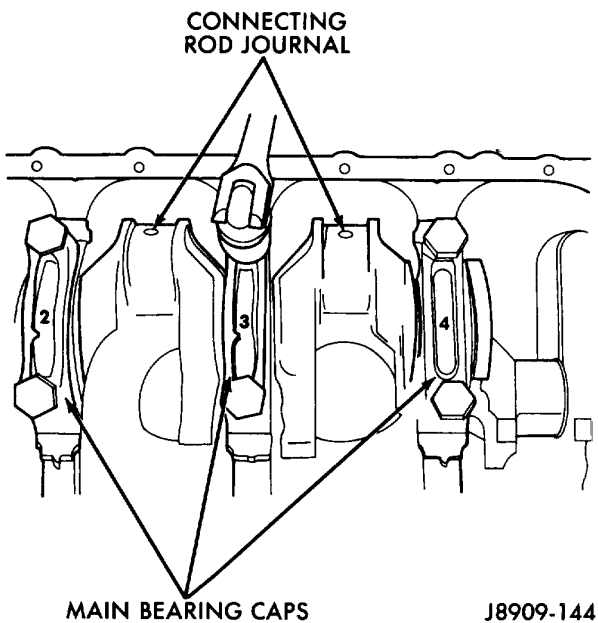

COTTER
PIN

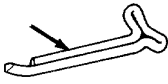

FABRICATED
TOOL

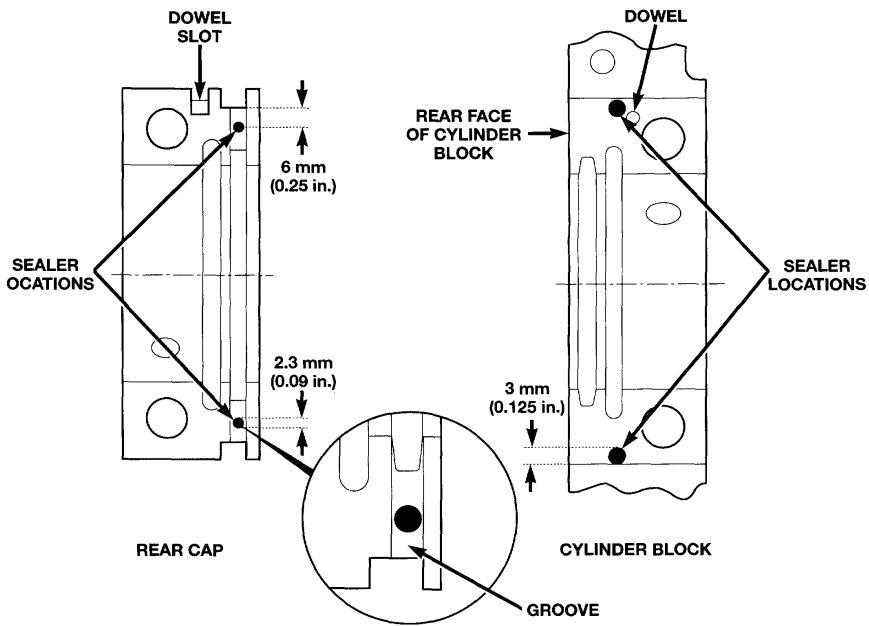
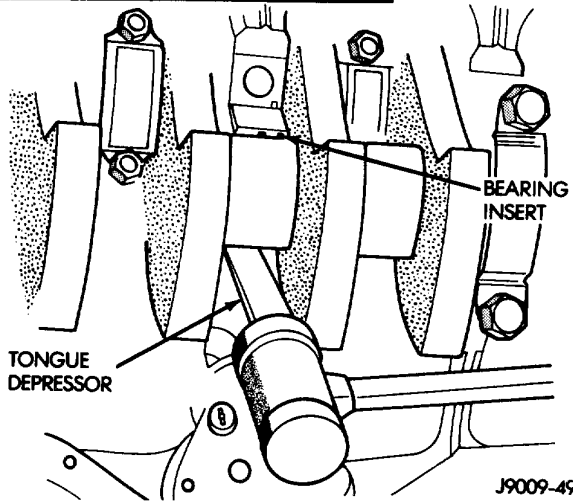

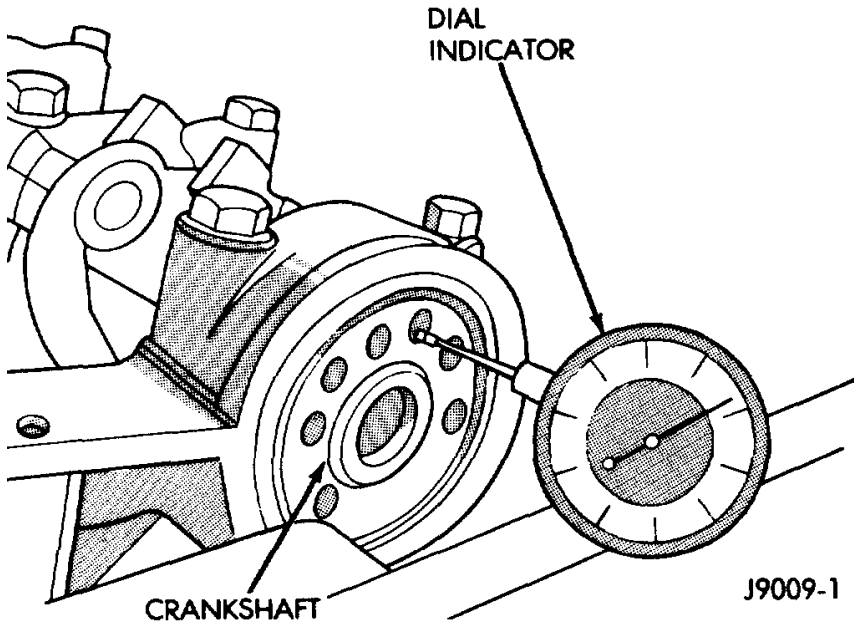

Rebuild Specifications (Article 2039310)

Crankshaft Journals #1 - #4		Corresponding Crankshaft Bearing Insert	
Color Code	Diameter	Upper Insert Size	Lower Insert Size
Yellow	63.5025-63.4898 mm (2.5001-2.4996 in.)	Yellow - Standard	Yellow - Standard
Orange	63.4898-63.4771 mm (2.4996-2.4991 in.) 0.0127 mm (0.0005 in.) Undersize	Blue - Undersize 0.025 mm (0.001 in.)	Yellow - Standard
Blue	63.4771-63.4644 mm (2.4991-2.4986 in.) 0.0254 mm (0.001 in.) Undersize	Blue - Undersize 0.025 mm (0.001 in.)	Blue - Undersize 0.025 mm (0.001 in.)
Green	63.4644-63.4517 mm (2.4986-2.4981 in.) 0.0381 mm (0.0015 in.) Undersize	Blue - Undersize 0.025 mm (0.001 in.)	Green - Undersize 0.051 mm (0.002 in.)
Red	63.2485-63.2358 mm (2.4901-2.4896 in.) 0.254 mm (0.010 in.) Undersize	Red - Undersize 0.254 mm (0.010 in.)	Red - Undersize 0.254 mm (0.010 in.)

Crankshaft Journals #5 Only		Corresponding Crankshaft Bearing Insert	
Color Code	Diameter	Upper Insert Size	Lower Insert Size
Yellow	63.4873-63.4746 mm (2.4995-2.4990 in.)	Yellow - Standard	Yellow - Standard
Orange	63.4746-63.4619 mm (2.4990-2.4985 in.) 0.0127 mm (0.0005 in.) Undersize	Blue - Undersize 0.025 mm (0.001 in.)	Yellow - Standard
Blue	63.4619-63.4492 mm (2.4985-2.4980 in.) 0.0254 mm (0.001 in.) Undersize	Blue - Undersize 0.025 mm (0.001 in.)	Blue - Undersize 0.025 mm (0.001 in.)
Green	63.4492-63.4365 mm (2.4980-2.4975 in.) 0.0381 mm (0.0015 in.) Undersize	Blue - Undersize 0.025 mm (0.001 in.)	Green - Undersize 0.051 mm (0.002 in.)
Red	63.2333-63.2206 mm (2.4895-2.4890 in.) 0.254 mm (0.010 in.) Undersize	Red - Undersize 0.254 mm (0.010 in.)	Red - Undersize 0.254 mm (0.010 in.)