

Component Procedures: Connecting Rod Bearing

Table of Contents

1. Parts and Labor (itype_189)
2. Components (itype_392)
3. Fitting Connecting Rod Bearings (Article 2036685)
4. Bearing Clearances (Article 2043035)

Component Procedures: Connecting Rod Bearing

Parts and Labor (itype_189)

Labor

Operation	Qualifier Path	Skill	Std Hrs	Wty Hrs
Replace	Connecting Rod Bearing > One	B	3.5	2.0
Replace	Connecting Rod Bearing > One > NOTE > To R&R ?	B	0.4	0.3
Replace	Connecting Rod Bearing > Each Additional	B	0.4	0.2
Replace	Connecting Rod Bearing > Each Additional > NO?	B	0.4	0.3

Components (itype_392)

CONNECTING ROD BEARING

CLEARANCE

Engine

connecting rod

bearing clearances can be determined by use of Plastigage, or equivalent. The following is the recommended procedures for the use of Plastigage:

1. Remove oil film from surface to be checked. Plastigage is soluble in oil.
2. Place a piece of Plastigage across the entire width of the bearing cap shell. Position the Plastigage approximately 6.35 mm (1/4 inch) off center and away from the oil holes. In addition, suspect areas can be checked by placing the Plastigage in the suspect area.
3. The crankshaft must be turned until the connecting rod to be checked starts moving toward the top of the engine. Only then should the rod cap with Plastigage in place be assembled. Tighten the rod cap nuts to required torque. DO NOT rotate the crankshaft or the Plastigage may be smeared, giving inaccurate results.
4. Remove the bearing cap and compare the width of the flattened Plastigage with the scale provided on the package. Plastigage generally comes in 2 scales (one scale is in inches and the other is a metric scale). Locate the band closest to the same width. This band shows the amount of clearance. Differences in readings between the ends indicate the amount of taper present. Record all readings taken.
5. Plastigage is available in a variety of clearance ranges. The 0.025 - 0.076 mm (0.001 - 0.003 inch) range is usually the most appropriate for checking engine bearing clearances.

Fitting Connecting Rod Bearings (Article 2036685)

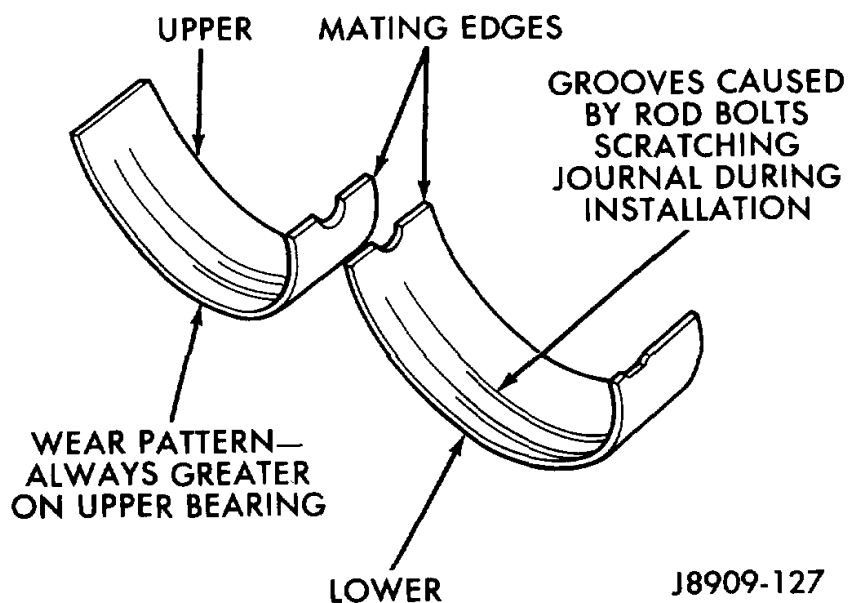

ABNORMAL CONTACT AREA
CAUSED BY LOCKING TABS NOT
FULLY SEATED OR BEING BENT

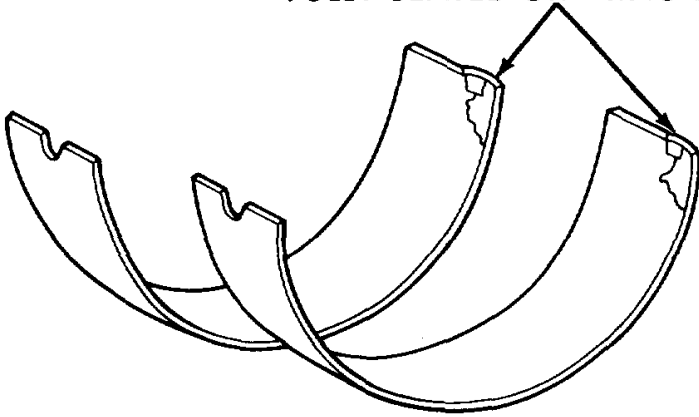

J8909-128

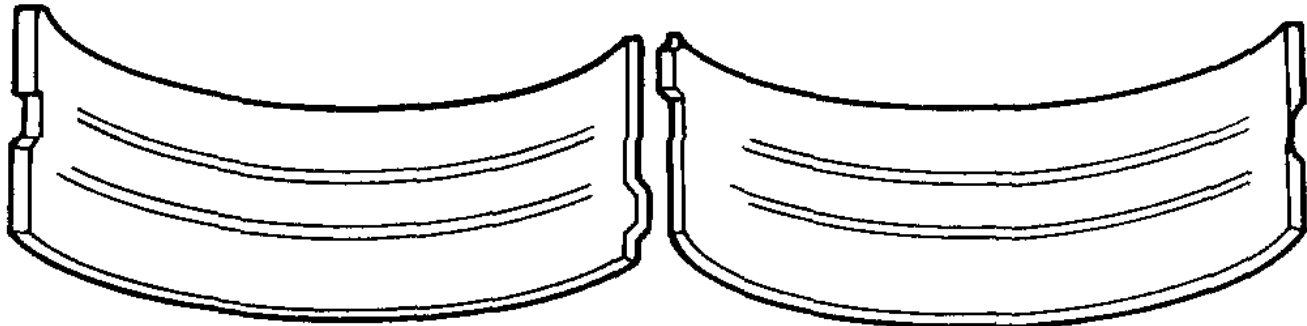

LOWER

UPPER

J8909-129

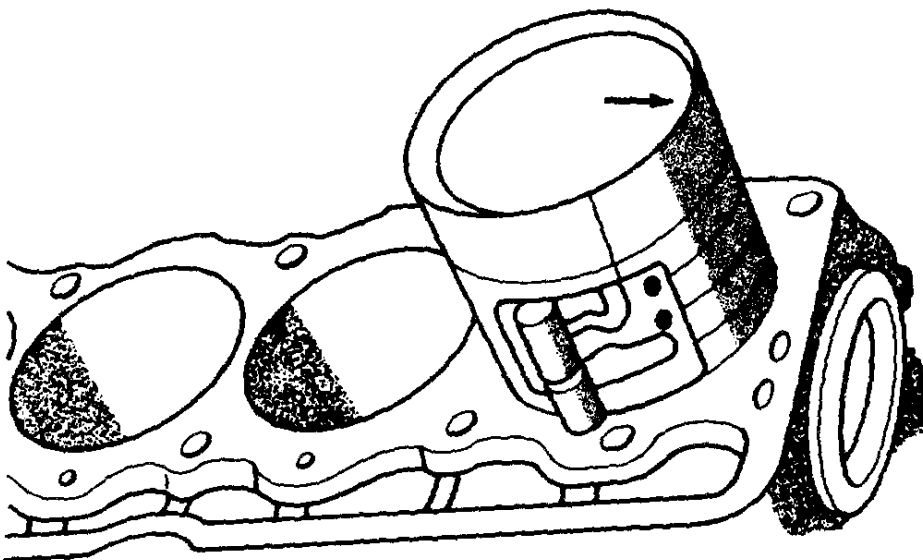

J9009-41

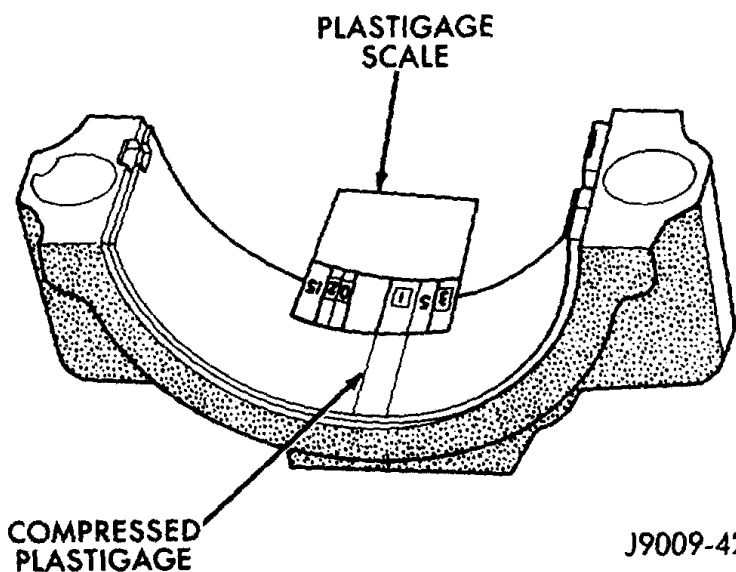

CRANKSHAFT JOURNAL		CORRESPONDING CONNECTING ROD BEARING INSERT	
Color Code	Diameter	Upper Insert Size	Lower Insert Size
Yellow	53.2257-53.2079 mm (2.0955-2.0948 in.)	Yellow - Standard	Yellow - Standard
Orange	53.2079 - 53.1901 mm (2.0948 - 2.0941 in.) 0.0178 mm (0.0014 in.) Undersize	Yellow - Standard	Blue - Undersize 0.025 mm (0.001 in.)
Blue	53.1901 - 53.1724 mm (2.0941 - 2.0934 in.) 0.0356 mm (0.0014 in.) Undersize	Blue - Undersize 0.025 mm (0.001 in.)	Blue - Undersize 0.025 mm (0.001 in.)
Red	52.9717 - 52.9539 mm (2.0855 - 2.0848 in.) 0.254 mm (0.010 in.) Undersize	Red - Undersize 0.254 mm (0.010 in.)	Red - Undersize 0.254 mm (0.010 in.)

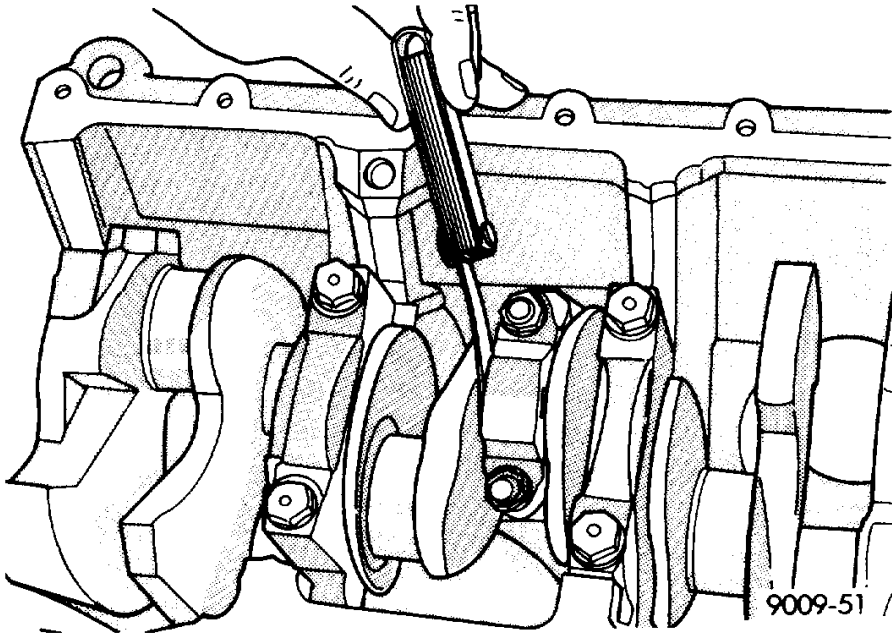

Bearing Clearances (Article 2043035)

Bearing Clearance

0.025-0.076 mm (0.001-0.003 in)

Preferred

0.044-0.050 mm (0.0015-0.0020 in)

Side Clearance

0.25-0.48 mm (0.010-0.019 in)