

Component Procedures: Fuel Gauge Sender

Table of Contents

1. Parts and Labor (itype_189)
2. Components (itype_392)
3. Connector Views (itype_47)
4. Components (itype_32)
5. Procedures (itype_376)
6. Component Tests and General Diagnostics (itype_383)

Component Procedures: Fuel Gauge Sender

Parts and Labor (itype_189)

Parts

Qualifier	Part #	Name	Price	Note
Fuel Gauge Sending Unit > 15?	4897756AD	Fuel Gauge Sending Unit	54.50	
Fuel Gauge Sending Unit > 19?	4897757AC	Fuel Gauge Sending Unit	56.45	

Labor

Operation	Qualifier Path	Skill	Std Hrs	Wty Hrs
Replace	Fuel Gauge Sending Unit, R&R	B	1.8	0.8

Components (itype_392)

SYSTEM OPERATION

The

fuel gauge sending unit

(

fuel level sensor

) is attached to the side of the

fuel pump module

. The sending unit consists of a float, an arm, and a variable resistor (track). The resistor track is used to send electrical signals to the

Powertrain Control Module

PCM

)

for

fuel gauge

operation and for OBD II emission requirements.

For fuel gauge operation: As fuel level increases, the float and arm move up. This decreases the sending unit resistance, causing the fuel gauge to read full. As fuel level decreases, the float and arm move down. This increases the sending unit resistance causing the fuel gauge to read empty.

After this fuel level signal is sent to the PCM, the PCM will transmit the data across the CCD bus

circuits to the

instrument panel

. Here it is translated into the appropriate fuel gauge level reading.

For OBD II emission monitor requirements: A

voltage signal

is sent from the resistor track on the sending unit to the PCM to indicate fuel level. The purpose of this feature is to prevent the OBD II system from recording/setting false misfire and

fuel system

monitor trouble codes. The feature is activated if the fuel level in the tank is less than approximately 15 percent

of its rated capacity. If equipped with a

Leak Detection Pump

EVAP system

monitor), this feature will also be activated if the fuel level in the tank is more than approximately

85 percent

of its rated capacity.

Connector Views (itype_47)

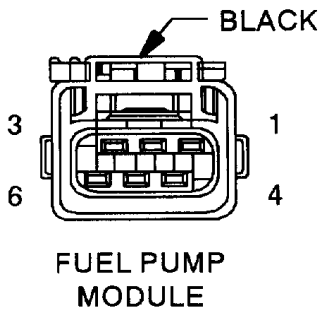

FUEL PUMP MODULE - BLACK 6 WAY

CAV	CIRCUIT	FUNCTION
1	A141 18DG/WT	FUEL PUMP RELAY OUTPUT
2	-	-
3	K226 20DB/LG	FUEL LEVEL SENSOR SIGNAL
4	K167 20BR/YL	SENSOR GROUND
5	-	-
6	Z1 18BK	GROUND

Components (itype_32)

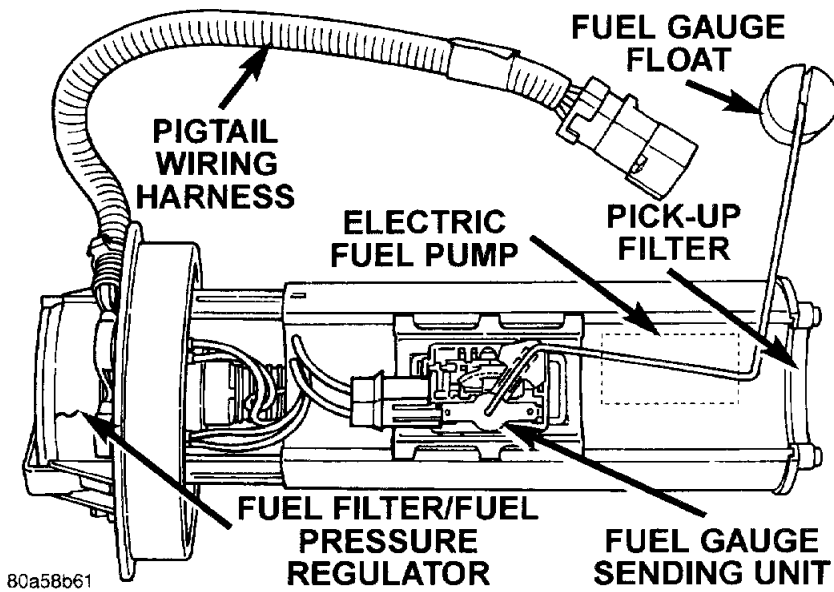

Procedures (itype_376)

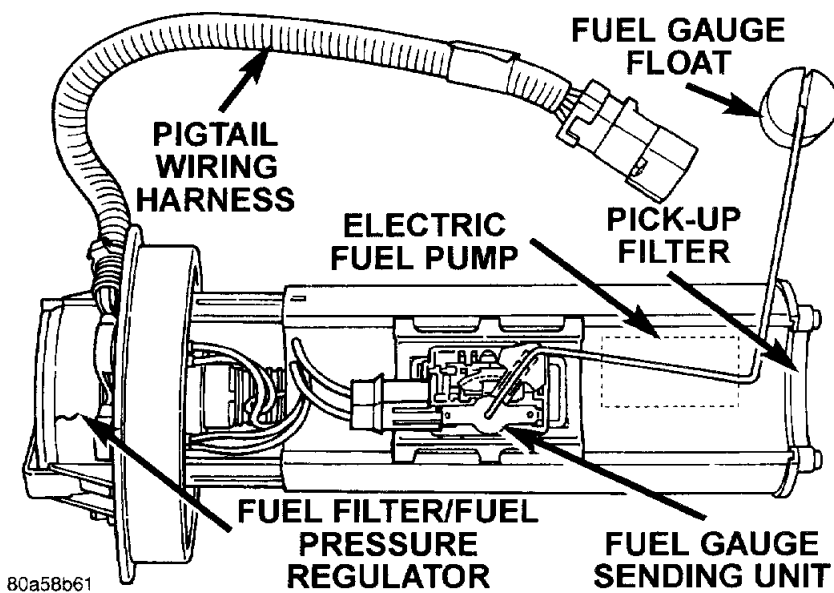

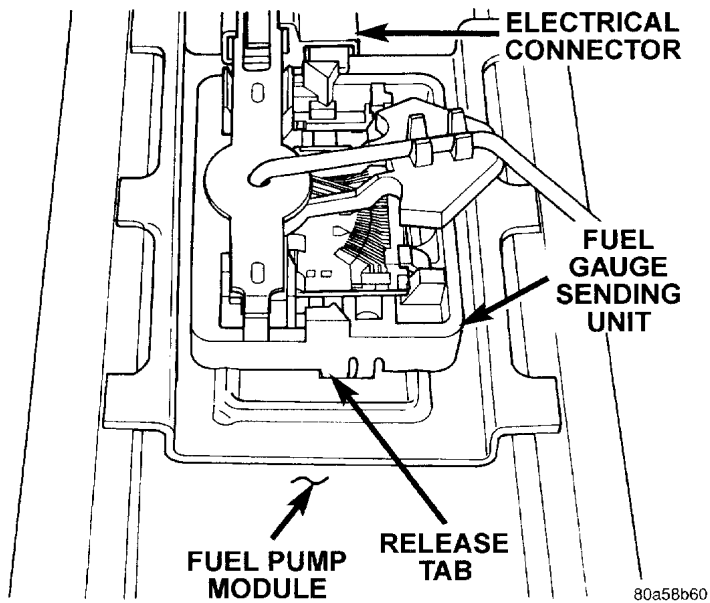

Component Tests and General Diagnostics (itype_383)

The fuel gauge sending unit contains a variable resistor (track). As the float moves up or down, electrical resistance will change. Refer to Instrument Panel and Gauges for Fuel Gauge testing. To test the gauge sending unit only, it must be removed from vehicle. The unit is part of the fuel pump module.

- . Refer to Fuel Pump Module Removal/ Installation for procedures. Measure the resistance across the sending unit terminals. With float in up position, resistance should be 20 ohms.
- . With float in down position, resistance should be 270 ohms.