

# **Component Procedures: Timing Chain**

## **Table of Contents**

1. Parts and Labor (itype\_189)
2. Timing Chain & Sprockets Replacement (Article 2049218)

# Component Procedures: Timing Chain

## Parts and Labor (itype\_189)

### Parts

Qualifier	Part #	Name	Price	Note
Timing Chain	J3242300	19 - Timing Chain	0.00	

### Labor

Operation	Qualifier Path	Skill	Std Hrs	Wty Hrs
Replace	Timing Chain, R&R	B	3.1	2.3
Replace	Timing Chain, R&R > NOTE > With AC, Add	B	0.9	0.6
Replace	Timing Chain, R&R > NOTE > With PS, Add	B	0.3	0.0

## Timing Chain & Sprockets Replacement (Article 2049218)

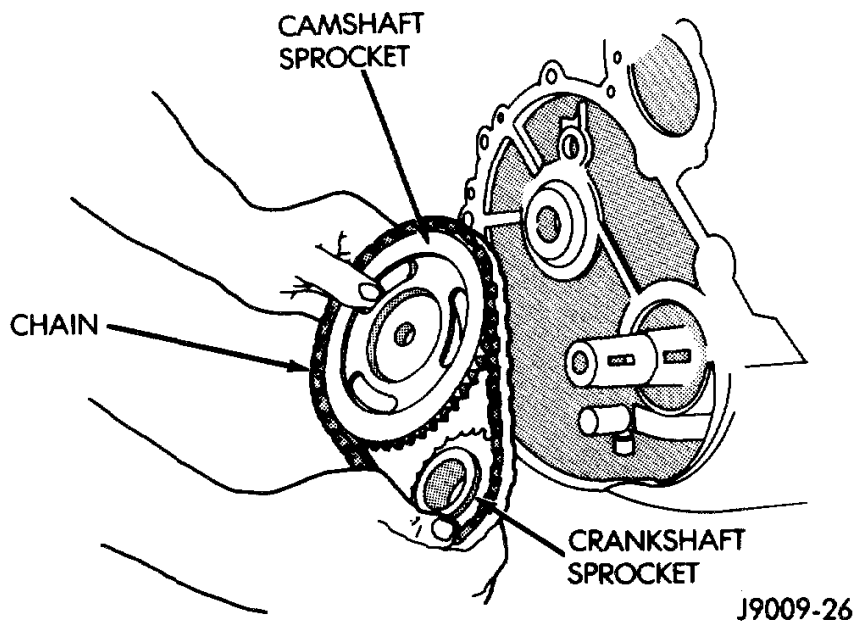
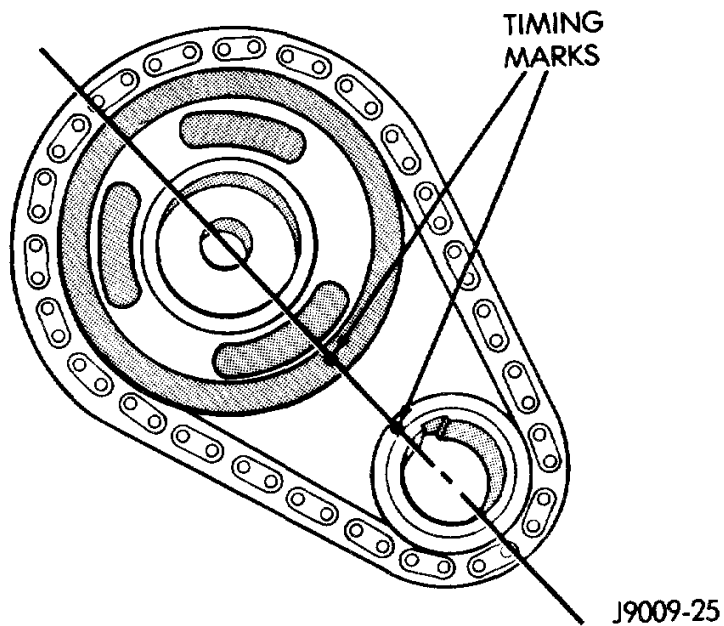

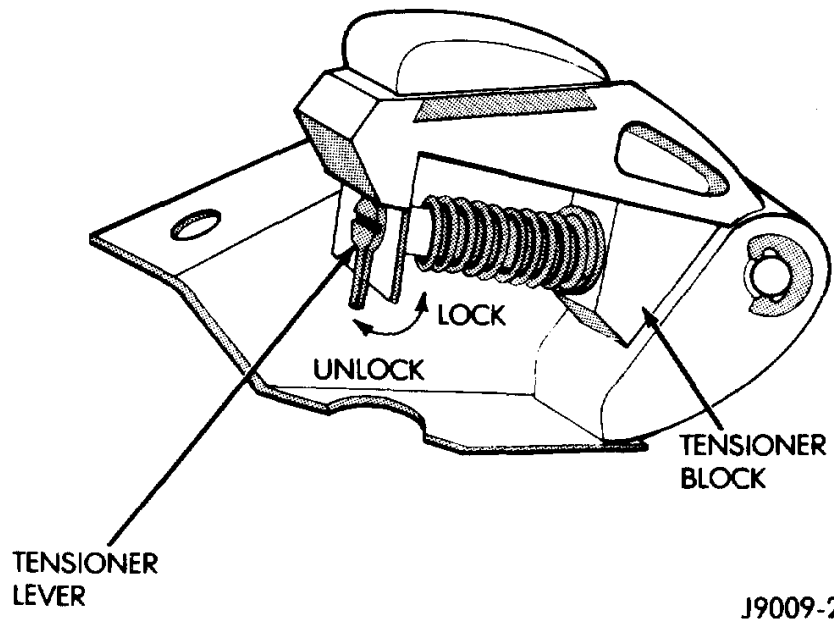

J9009-27

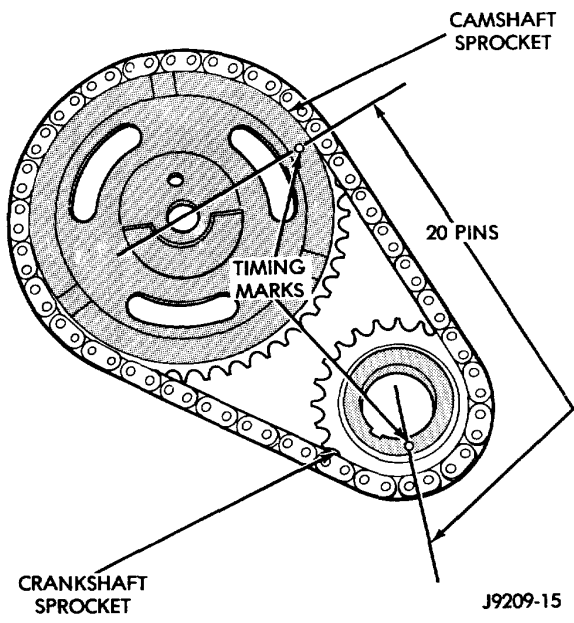

J9209-15