

Component Procedures: Air Bag Systems

Table of Contents

1. Parts and Labor (itype_189)
2. Components (itype_392)
3. Wiring Diagrams (Article 2072661)
4. Schematic Diagrams (Article 2072660)
5. All Technical Service Bulletins (itype_100)
6. Customer Interest Bulletins (itype_109)
7. Repair Tips (itype_110)
8. Diagnostic Strategies (Article 2072749)
9. Electrical / Mechanical Repair (itype_413)
10. Erratic Operation (itype_132)
11. New / Updated Parts (itype_117)

Component Procedures: Air Bag Systems

Parts and Labor (itype_189)

Labor

Operation	Qualifier Path	Skill	Std Hrs	Wty Hrs
Diagnose/Test	System, Diagnosis	B	0.5	0.0

Components (itype_392)

AIRBAG SYSTEM

The airbag system is designed to provide increased driver and passenger protection if the vehicle is involved in a front-end collision. The system is designed to be used in conjunction with the seat belt system.

Currently, Chrysler Corporation uses two types of

Airbag Control Module

s

(

ACM

)

. The

ASDM

system is a mechanically-triggered system utilizing two front impact sensors and a sensor inside the module.

The

AECM

is an electronically-triggered system that uses only its own internal electronic sensor to trigger the airbags. The TJ Body uses only the AECM system.

Whenever the ignition key is turned to the RUN or START position, the Airbag Control Module (ACM) performs a lamp check by turning the AIRBAG warning lamp on. The lamp stays lit for

6

to

8 seconds

, then goes OFF. If the lamp remains OFF, it means the ACM has checked the system and found it to be free of discernable malfunctions. The airbag system is monitored by the ACM.

The ACM monitors critical input and output circuits within the airbag system, making sure they are operating correctly. Some circuits are tested continuously; others are checked only under certain circumstances. The ACM provides diagnostic information about the airbag system to the technician through the DRB via the CCD bus.

The AIRBAG warning lamp is the only point at which "symptoms" of a system malfunction can be observed by the customer.

The deceleration or g-force resulting from the impact of a front-end collision causes the electronic sensor inside of the ACM to be triggered. This causes the inflators to be actuated, thus deploying the airbags. The total time between determining to deploy and deflation of the airbag is

1/10th

of a second.

1999 Wranglers will be equipped with a passenger airbag ON/OFF switch. This switch has an LED that will light when the switch is in the "OFF" position. While in the "OFF" position a circuit board inside the switch will simulate a passenger airbag to prevent the ACM from logging a DTC. However it is important that the ignition be in the OFF before moving the ON/OFF switch to the OFF or ON position, otherwise the ACM may log a DTC and turn on the airbag warning lamp due to a momentary open of the switch contacts.

Use the test procedures in this book to find the cause of any customer complaint regarding the AIRBAG warning lamp such as:

- warning lamp does not come on at all

- warning lamp stays ON

AIRBAG DIAGNOSTIC TROUBLE CODES

Airbag diagnostic trouble codes consist of active and stored codes. If more than one exists, diagnostic priority should be given to the active code(s).

Each diagnostic trouble code is diagnosed by following a specific testing procedure. The diagnostic test procedures contain step-by-step instructions for determining the cause of the trouble codes. It is necessary to perform all of the tests in this book to diagnose an individual code.

Always begin by reading the diagnostic trouble codes using the DRB. If more than one code exists, diagnostic

priority should be given to the active code(s).

Active diagnostic trouble codes for the airbag system are not permanent and will change the moment the reason for the code is corrected. In certain test procedures, diagnostic trouble codes are used as a diagnostic tool.

Active Codes

An active trouble code indicates an on-going malfunction. This means that the defect is currently there every time the airbag control module checks that circuit/function. It is impossible to erase an active code; active codes automatically erase themselves when the reason for the code has been corrected.

With the exception of the warning lamp trouble codes or malfunctions, when a malfunction is detected, the AIRBAG lamp remains lit for a minimum of

12 seconds

or as long as the malfunction is present.

Stored Codes

Airbag codes are automatically stored in the ACM's memory when the ignition is turned OFF with the exception of the Loss of Ignition Run Only code, which is an active code only.

A "stored" code indicates there was an active code present at some time. However, the code currently may not be present as an active code, although another active code could be.

When a trouble code occurs, the AIRBAG warning lamp illuminates for minimum (even if the problem existed for less than

). The code is stored, along with the time

in minutes

it was active, and the number of times the ignition has been cycled since the problem was last detected.

The minimum time shown for any code will be one minute, even if the code was actually present for less than one minute. Thus, the time shown for a code that was present for

two minutes

13 seconds

, for example, would be

three minutes

If a malfunction is not active while performing a diagnostic test procedure, the active code diagnostic test will not locate the source of the problem. In this case, the stored code can indicate an area to inspect.

If no obvious problems are found, erase stored codes, and with the ignition "ON", wiggle the wire harness and connectors, rotate the steering wheel from stop to stop. Recheck for codes periodically as you work through the system. This procedure may uncover a malfunction that is difficult to locate.

Airbag Trouble Codes

The Airbag Control Module may report any of the following diagnostic trouble codes.

For the following ACTIVE OR STORED codes, replace the Airbag Control Module (ACM) even if set intermittently:

- AECM Accelerometer
- Internal Diagnostic 1
- AECM Output Driver
- AECM Stored Energy Logic
- AECM Stored Energy Driver
- AECM Stored Energy Passenger
- Internal Diagnostic 2
- Internal Diagnostic 3
- Internal Diagnostic 4
- Safing Sensor Shorted

For these codes, refer to the appropriate diagnostic procedure:

- Driver Squib Circuit Open
- Driver Squib Circuit Shorted
- Loss of Ignition Run Only
- Loss of Ignition to Run/Start
- No Cluster CCD Bus Message
- No CCD Communication
- Passenger Squib Circuit Shorted
- Passenger Squib Circuit Open
- Either Squib Term Shorted to Battery
- Either Squib Term Short to Ground
- Warning Lamp Circuit Open/Shorted

Wiring Diagrams (Article 2072661)

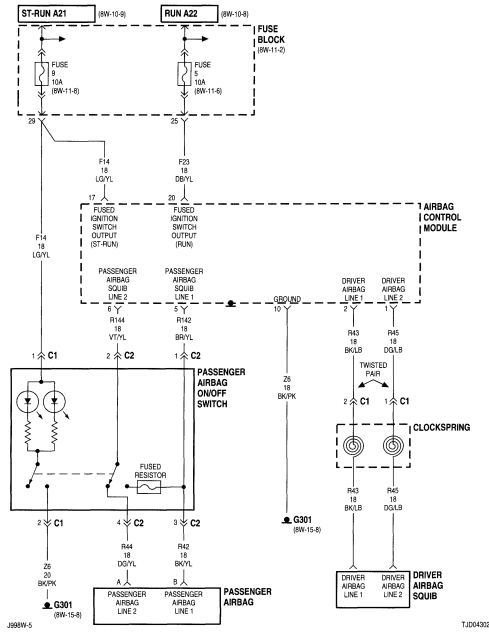

J999W-5 TJD04302

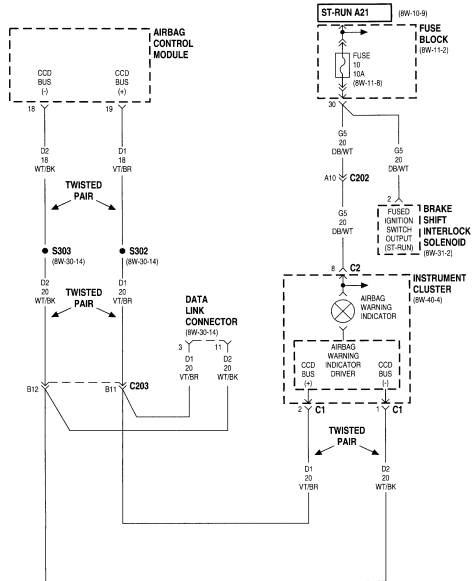

TJ04303 J999W-5

Schematic Diagrams (Article 2072660)

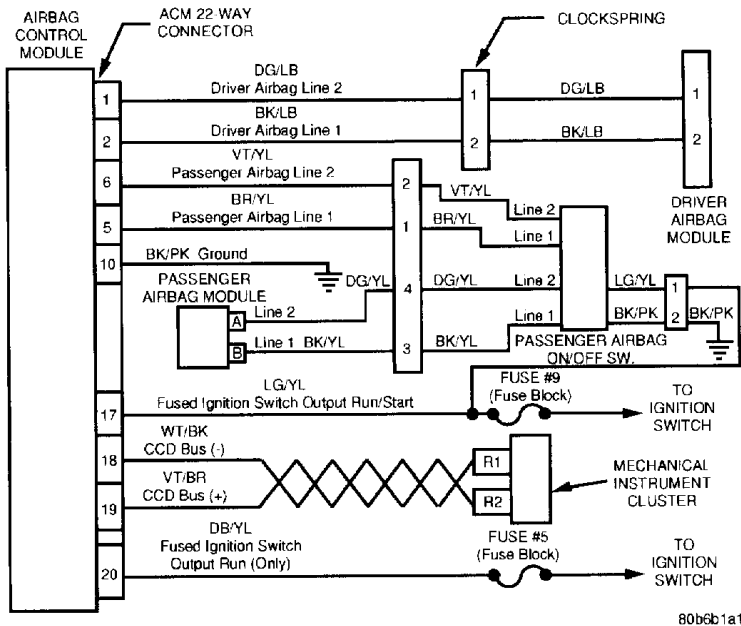

All Technical Service Bulletins (itype_100)

Tsbs

- Restraints - Use Of Salvaged Restraint System Components (31-003-11, 2011/11/10)
- Restraints - Replacement Seat Covers/Seat Cover Repairs (31-004-11, 2011/11/10)
- Air Bag - On/Off Switches (08-025-01, 2001/11/23)
- Airbag/Clock Spring - Service (08-010-01, 2001/05/25)
- Driver Airbag - Trim Cover Service (19-009-01, 2001/10/26)
- Air Bag System - ON-OFF Switch Availability (08-17-98C, 1998/12/30)
- Instrument Cluster - Intermittent/Erratic Operation (08-15-99, 1999/05/21)

Customer Interest Bulletins (itype_109)

Tsbs

- Instrument Cluster - Intermittent/Erratic Operation (08-15-99, 1999/05/21)

Repair Tips (itype_110)

Tsbs

- Restraints - Use Of Salvaged Restraint System Components (31-003-11, 2011/11/10)
- Restraints - Replacement Seat Covers/Seat Cover Repairs (31-004-11, 2011/11/10)
- Air Bag - On/Off Switches (08-025-01, 2001/11/23)
- Airbag/Clock Spring - Service (08-010-01, 2001/05/25)
- Air Bag System - ON-OFF Switch Availability (08-17-98C, 1998/12/30)

Diagnostic Strategies (Article 2072749)

Non Standards

- BCM Related Diagnostic Charts (2072751)

Electrical / Mechanical Repair (itype_413)

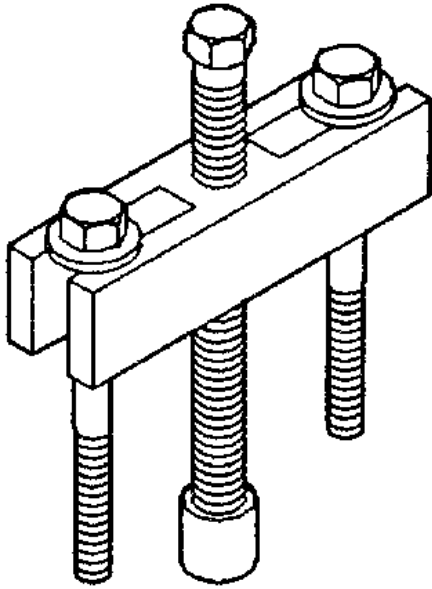

Erratic Operation (itype_132)

Tsbs

- Instrument Cluster - Intermittent/Erratic Operation (08-15-99, 1999/05/21)

New / Updated Parts (itype_117)

Tsbs

- Driver Airbag - Trim Cover Service (19-009-01, 2001/10/26)
- Instrument Cluster - Intermittent/Erratic Operation (08-15-99, 1999/05/21)