

Component Procedures: Speaker

Table of Contents

1. Parts and Labor (itype_189)
2. Components (itype_392)
3. Components (itype_32)
4. Instrument Panel Speaker Replacement (Article 2072086)
5. Sound Bar 1 Replacement (Article 2072087)
6. Sound Bar 2 Replacement (Article 2072088)
7. Technician Safety Information (itype_15)
8. Mechanical (including Torque) (itype_28)
9. Component Tests and General Diagnostics (itype_383)

Component Procedures: Speaker

Parts and Labor (itype_189)

Labor

| Operation | Qualifier Path | Skill | Std Hrs | Wty Hrs |
|-----------|----------------------------------|-------|---------|---------|
| Replace | Door Radio Speaker > One Side | C | 0.5 | 0.3 |
| Replace | Front Speaker > Left Side | C | 1.0 | 0.8 |
| Replace | Front Speaker > Right Side | C | 0.5 | 0.4 |
| Replace | Rear Speaker > Sound Bar Mounted | C | 0.4 | 0.3 |

Components (itype_392)

DESCRIPTION

The standard equipment speaker

system includes two full-range speakers. Each speaker is mounted behind a removable bezel located on the outboard ends of the lower instrument panel.

The sound bar option adds two full-range speakers to the standard speaker system, for a total of four speakers. Each of the additional speakers is mounted behind a grille located on the outboard ends of the sound bar, which is attached from side-to-side to the sport bar above the rear seating area of the vehicle.

Components (itype_32)

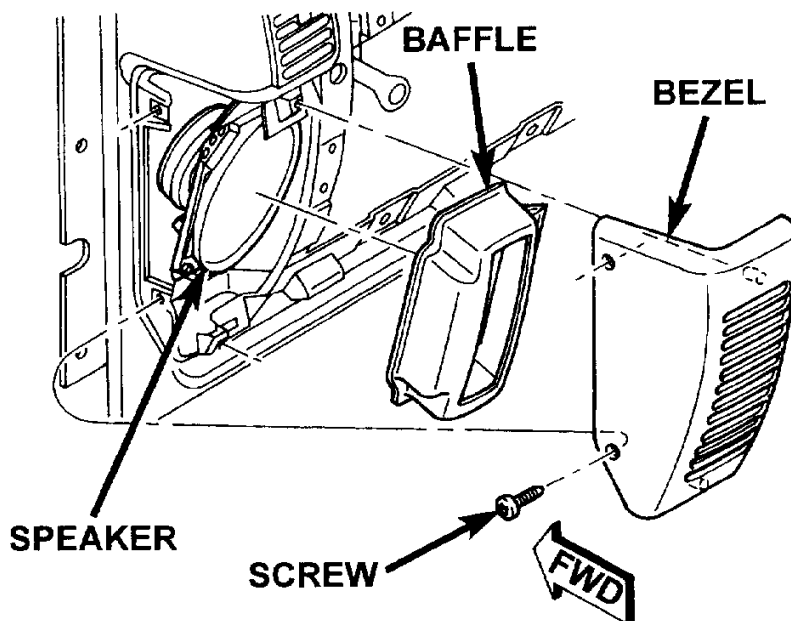

80aa980f

Instrument Panel Speaker Replacement (Article 2072086)

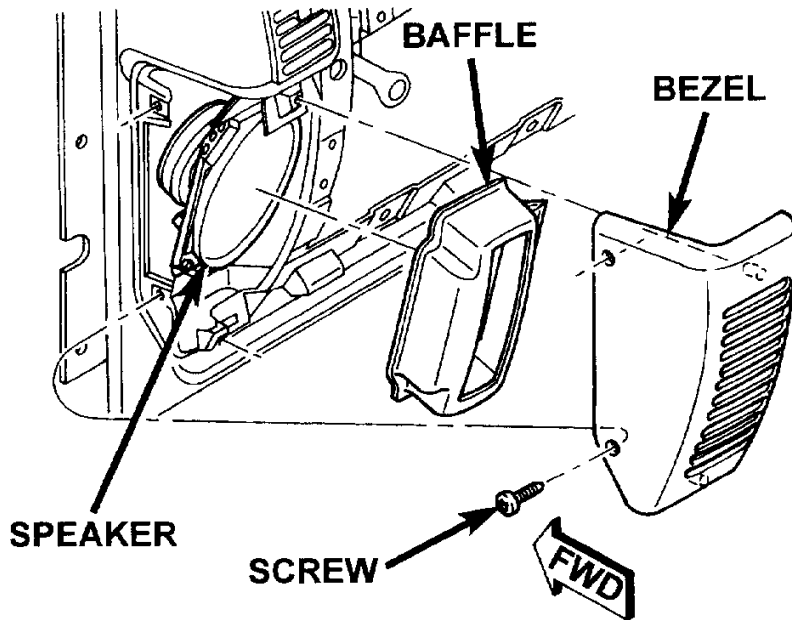

80aa980f

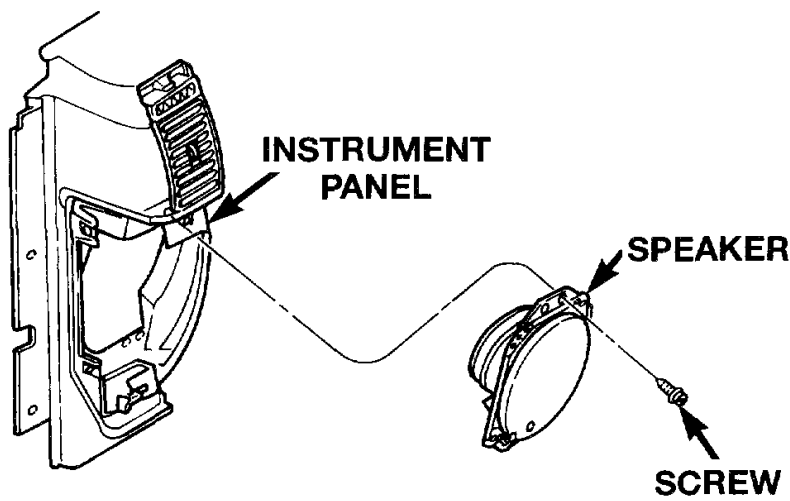

80a483de

Sound Bar 1 Replacement (Article 2072087)

REMOVAL

1. Disconnect and isolate the battery negative cable.
2. Remove the four screws that secure the speaker grille and speaker to the sound bar.
3. Lower the speaker and grille from the sound bar far enough to access the speaker wire harness connector.
4. Unplug the wire harness connector from the speaker.
5. Remove the speaker and grille from the sound bar.
6. Remove the speaker grille from the speaker.
7. Reverse the removal procedures to install. Tighten the mounting screws to 1.1 Nm (10 in. lbs.)

Sound Bar 2 Replacement (Article 2072088)

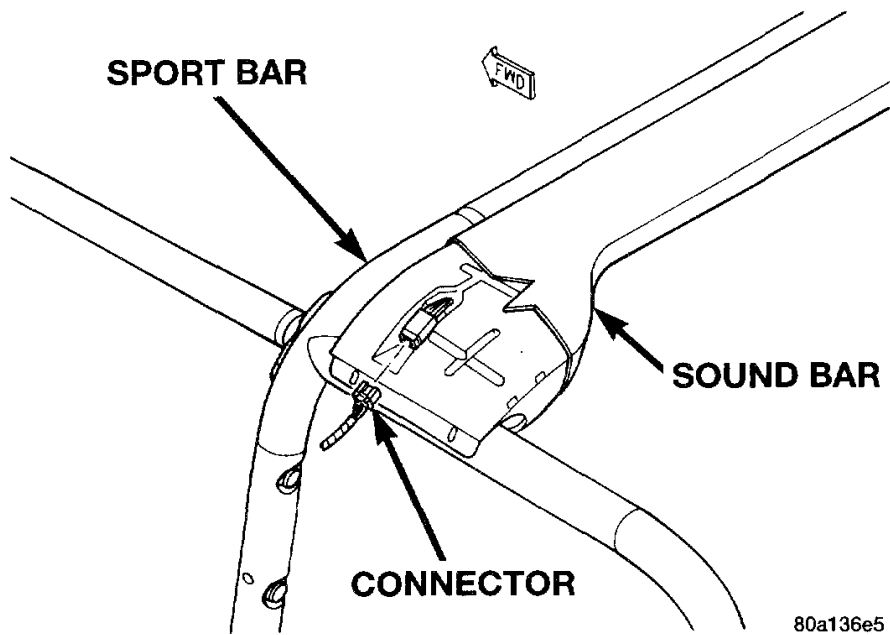

80a136e5

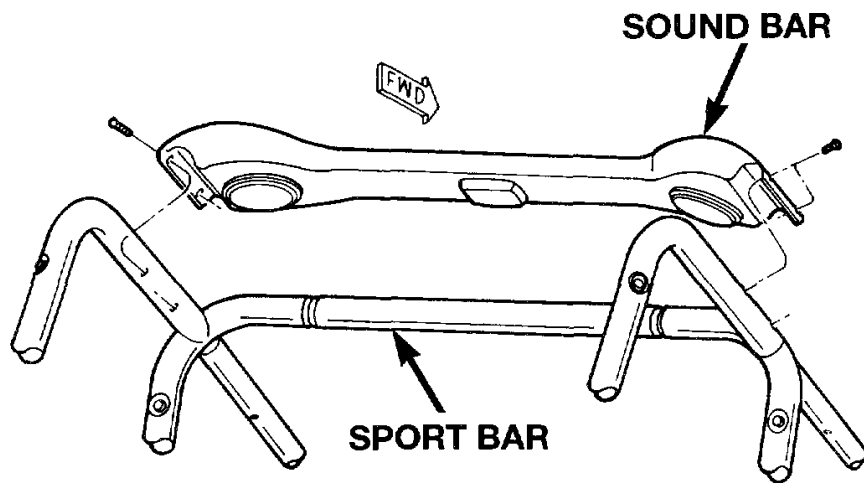

80a136e6

Technician Safety Information (itype_15)

WARNING: ON VEHICLES EQUIPPED WITH AIRBAGS, REFER TO RESTRAINT SYSTEMS / AIRBAG SYSTEMS BEFORE ATTEMPTING A STEERING WHEEL, STEERING COLUMN, OR INSTRUMENT PANEL COMPONENT DIAGNOSIS OR SERVICE. FAILURE TO TAKE THE PROPER PRECAUTIONS COULD RESULT IN ACCIDENTAL AIRBAG DEPLOYMENT AND POSSIBLE PERSONAL INJURY

Mechanical (including Torque) (itype_28)

Tighten the speaker mounting screws to 1.1 Nm (10 in. lbs.)

Tighten the speaker bezel mounting screws to 2.2 Nm (20 in. lbs.)
 Tighten the mounting screws to
 Tighten the sound bar mounting screws to 11 Nm (100 in. lbs.)

Component Tests and General Diagnostics (itype_383)

WARNING: ON VEHICLES EQUIPPED WITH AIR-BAGS, REFER TO AIRBAG AND SEAT BELTS/AIR BAGS BEFORE ATTEMPTING ANY STEERING WHEEL, STEERING COLUMN, OR INSTRUMENT PANEL COMPONENT DIAGNOSIS OR SERVICE. FAILURE TO TAKE THE PROPER PRECAUTIONS COULD RESULT IN ACCIDENTAL AIR-BAG DEPLOYMENT AND POSSIBLE PERSONAL INJURY

CAUTION

: The speaker output of the radio

is a "floating ground" system. Do not allow any speaker lead to short to ground, as damage to the radio may result.

1. Turn the ignition switch to the On position. Turn the radio on. Adjust the balance and fader controls to check the performance of each individual speaker. Note the speaker locations that are not performing correctly. Go to Step 2.

2. Turn the radio off. Disconnect and isolate the battery negative cable. Remove the radio. Unplug the wire harness connectors at the radio. Check both the speaker feed (+) circuit and return (-) circuit cavities for the inoperative speaker location(s) at the radio wire harness connectors for continuity to ground. In each case, there should be no continuity. If OK, go to Step 4. If not OK, go to Step 3.

3. Leave the radio wire harness connectors unplugged. Unplug the wire harness connector at the inoperative speaker. Check both the speaker feed (+) circuit and return (-) circuit cavities of the speaker wire harness connector for continuity to ground. In each case, there should be no continuity. If OK, replace the shorted speaker. If not OK, repair the shorted circuit as required.

4. Plug in the speaker wire harness connector. Check the resistance between the speaker feed (+) circuit and return (-) circuit cavities of the radio wire harness connectors for the inoperative speaker location(s). The meter should read between

3 and 8 ohms

(speaker resistance). If OK, go to Step 5. If not OK, go to Step 6.

5. Install a known good radio. Connect the battery negative cable. Turn the ignition switch to the On position. Turn on the radio and test the speaker operation. If OK, replace the faulty radio. If not OK, replace the faulty speaker.

6. Turn the radio off. Turn the ignition switch to the Off position. Disconnect and isolate the battery negative cable. Remove the test radio. Unplug the speaker wire harness connector at the inoperative speaker. Check the resistance between the speaker feed (+) circuit cavities of the radio wire harness connector and the speaker wire harness connector. Repeat the check between the speaker return (-) circuit cavities of the radio wire harness connector and the speaker wire harness connector. In each case, there should be no measurable resistance. If OK, replace the faulty speaker. If not OK, repair the speaker wire harness circuit(s) as required.