

Component Procedures: Oil Pan

Table of Contents

1. Parts and Labor (itype_189)
2. Removal and Installation (Article 2071512)
3. Mechanical (including Torque) (itype_28)

Component Procedures: Oil Pan

Parts and Labor (itype_189)

Parts

Qualifier	Part #	Name	Price	Note
Oil Pan	53020560	32 - Oil Pan	0.00	

Labor

Operation	Qualifier Path	Skill	Std Hrs	Wty Hrs
Replace	Oil Pan, R&R	B	2.7	1.7

Removal and Installation (Article 2071512)

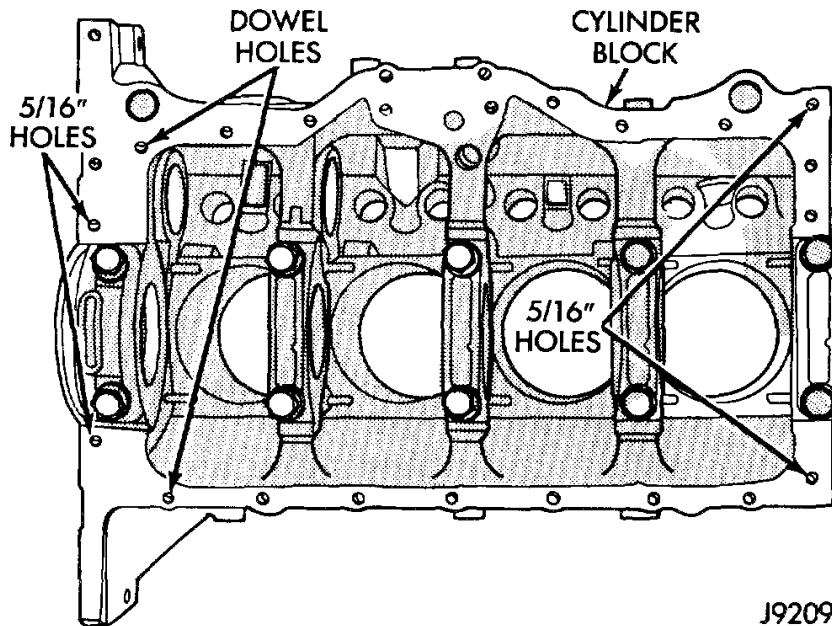
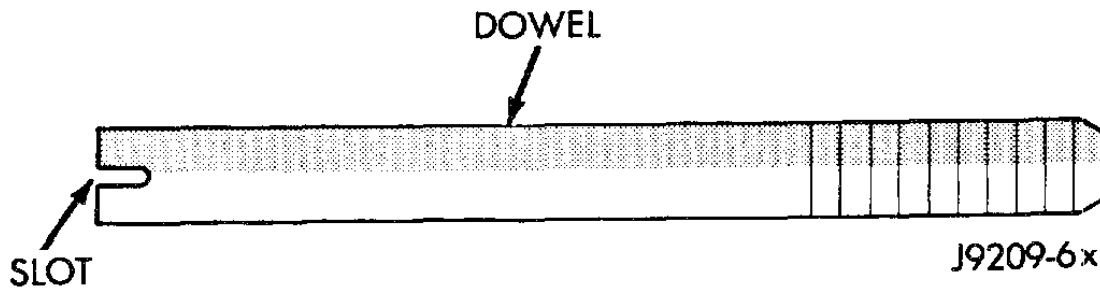
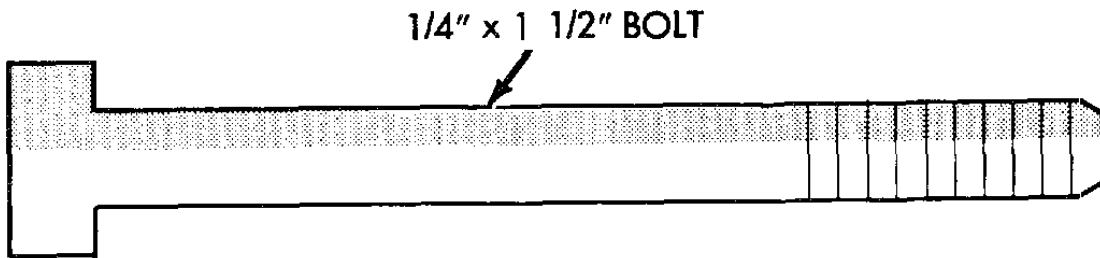

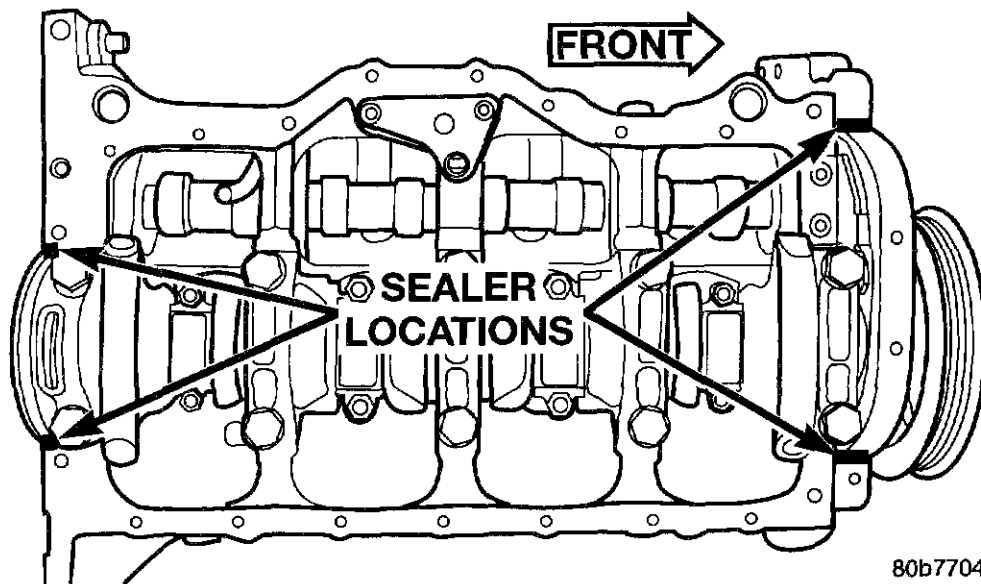

80b7704a

(A) 5/16" BOLTS

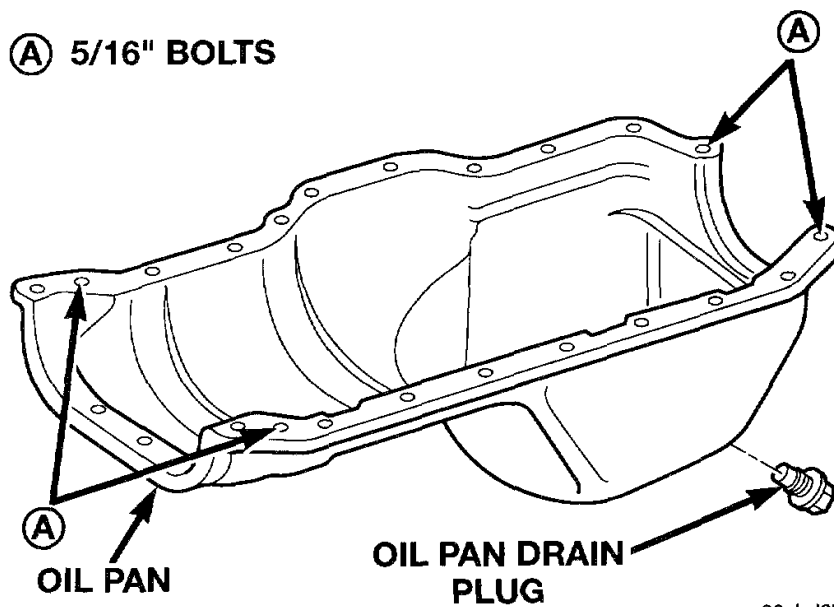

80abd2b5

Mechanical (including Torque) (itype_28)

Oil Pan 1/4 - 20 Bolts 84 in.lb

5/16 - 18 Bolts 132 in.lb

Drain Plug 25 ft.lb