

Component Procedures: Engine

Table of Contents

1. Exploded Parts Diagram (itype_83)
2. Parts and Labor (itype_189)
3. Engine Description and Operation (Article 2047653)
4. Removal and Installation (Article 2047227)
5. Cleaning and Inspection (Article 2047235)
6. Disassembly and Assembly (Article 2047240)
7. Standard Procedures (Article 2047228)
8. General Specifications (Article 2038539)
9. Engine Dimensions (Article 2038540)
10. Tightening Specifications (Article 2038541)
11. All Technical Service Bulletins (itype_100)
12. General Information (Article 2047375)
13. Diagnosis and Testing Procedures (Article 2047376)
14. Diagnosis By Symptom (Article 2047203)
15. Electrical / Mechanical Repair (itype_413)
16. Emissions (itype_106)

Component Procedures: Engine

Exploded Parts Diagram (itype_83)

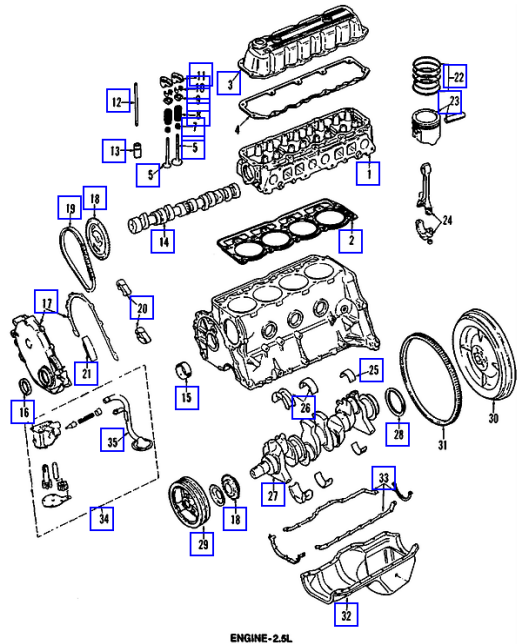

Parts and Labor (itype_189)

Parts

Qualifier	Part #	Name	Price	Note
Short Block	4856744	Engine Assembly, Engin?	970.00	Includes: Block With Pisto?
Overhaul Gasket Set > Lower ?	4713023AD	Overhaul Gasket Set	0.00	For Complete Overhaul Set,?
Overhaul Gasket Set > Upper ?	4798992AC	Overhaul Gasket Set	58.45	For Complete Overhaul Set,?

Labor

Operation	Qualifier Path	Skill	Std Hrs	Wty Hrs
Replace	Complete Assembly With Transfer Of Parts	B	10.0	0.0
Replace	Complete Assembly With Transfer Of Parts > NO?	B	1.0	0.0
Replace	Complete Assembly With Transfer Of Parts > NO?	B	0.5	0.0
Replace	Complete Assembly With Transfer Of Parts > NO?	B	0.7	0.0
Replace	Complete Assembly Without Transfer Of Parts	B	7.0	0.0
Replace	Complete Assembly Without Transfer Of Parts >?	B	1.0	0.0
Replace	Complete Assembly Without Transfer Of Parts >?	B	0.5	0.0
Replace	Complete Assembly Without Transfer Of Parts >?	B	0.7	0.0
Replace	Long Block	B	13.5	0.0
Replace	Long Block > NOTE > With AC, Add	B	1.0	0.0
Replace	Long Block > NOTE > With PS, Add	B	0.5	0.0
Replace	Long Block > NOTE > With Skid Plate, Add	B	0.7	0.0
Replace	Short Block	A	15.5	7.6
Replace	Short Block > NOTE > To Grind Valves, Add	A	2.6	2.2
Replace	Short Block > NOTE > With AC, Add	A	1.0	0.8
Replace	Short Block > NOTE > With PS, Add	A	0.5	0.3
Replace	Short Block > NOTE > With Skid Plate, Add	A	0.7	0.4
Overhaul/Rebuild	Engine, Overhaul	A	27.5	0.0
Overhaul/Rebuild	Engine, Overhaul > NOTE > With AC, Add	A	1.0	0.0
Overhaul/Rebuild	Engine, Overhaul > NOTE > With PS, Add	A	0.5	0.0
Overhaul/Rebuild	Engine, Overhaul > NOTE > With Skid Plate, Add	A	0.7	0.0

Engine Description and Operation (Article 2047653)

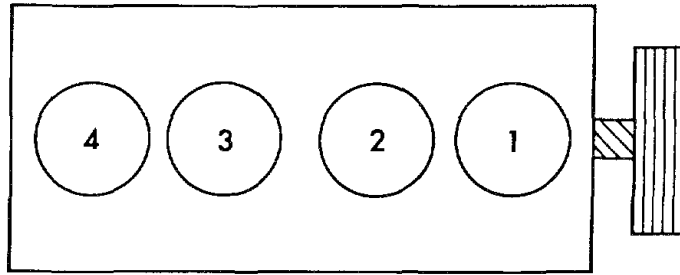

ENGINE
FIRING ORDER

1-3-4-2

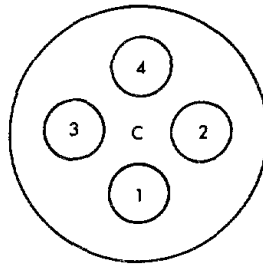

J9209-3

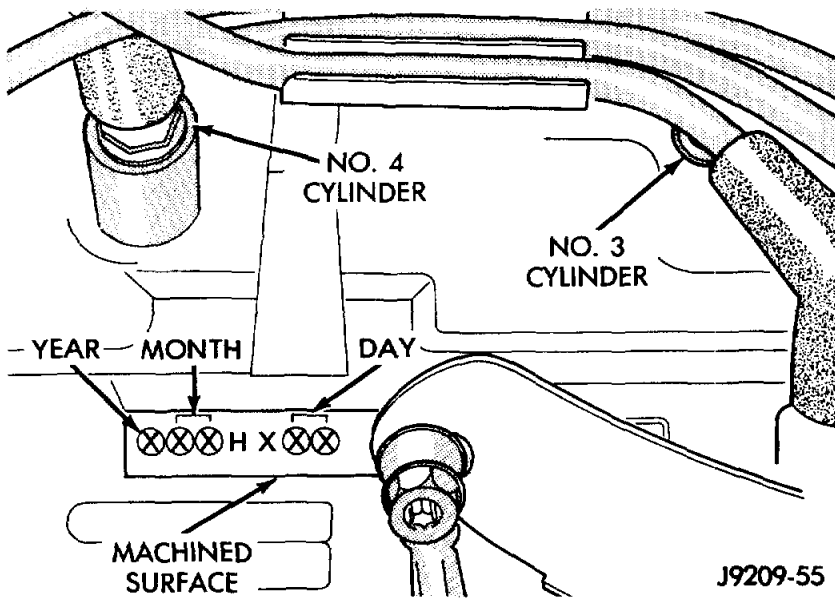

Removal and Installation (Article 2047227)

Non Standards

- Removal (2047233)
- Installation (2047234)

Cleaning and Inspection (Article 2047235)

Non Standards

- Cylinder Block (2047236)
- Cylinder Head (2047237)
- Hydraulic Valve Tappets (2047238)
- Rocker Arms and Pushrods (2047239)

Disassembly and Assembly (Article 2047240)

Non Standards

- Cylinder Block (2047241)

- Cylinder Head (2047250)

Standard Procedures (Article 2047228)

Non Standards

- Engine Performance (2047229)
- Form-In-Place Gaskets (2047230)
- Hydrostatic Locked Engine (2047231)
- Measuring With Plastigage (2047242)
- Repair Damaged or Worn Threads (2047232)
- Service Engine Assembly (Short Block) (2047243)

General Specifications (Article 2038539)

Engine Type In-Line 4-Cylinder, OHV

Bore 98.4 mm (3.88 in.)

Stroke 81.0 mm (3.19 in.)

Displacement 2.5L (150 cu. in.)

Compression Ratio 9.1 : 1

Cylinder Compression Pressure 827-1034 kPa (120-150 psi)

Max. Pressure Variation 206 kPa (30 psi)

Torque 190 Nm (140 ft. lbs.) @ 3500 rpm

Firing Order 1-3-4-2

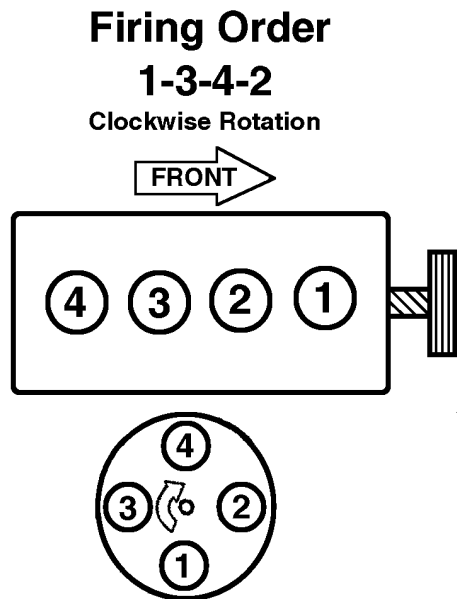

Lubrication Pressure Feed-Full Flow Filtration

Engine Oil Capacity 3.8L (4.0 qts)

Cooling System Liquid Cooled-Forced Circulation

Cooling System Capacity 8.5L (9 qts)

Cylinder Block Cast Iron

Crankshaft Cast Nodular Iron

Cylinder Head Cast Nodular Iron

Camshaft Cast Nodular Iron

Pistons Aluminum Alloy (with struts)

Piston Combustion Cavity Double Quench

Connecting Rods Cast Nodular Iron

Engine Dimensions (Article 2038540)

Camshaft

Hydraulic Tappet Clearance Zero Lash

Bearing Clearance 0.025 - 0.076 mm 0.001 - 0.003 in.

Bearing Journal Diameter

No. 1 51.54 - 51.56 mm 2.029 - 2.030 in.
No. 2 51.28 - 51.31 mm 2.019 - 2.020 in.
No. 3 51.03 - 51.05 mm 2.009 - 2.010 in.
No. 4 50.78 - 50.80 mm 1.999 - 2.000 in.
Base Circle Runout 0.03 mm - max. 0.001 in. - max.
Camshaft Lobe Lift
Exhaust 6.579 mm 0.259 in.
Intake 6.477 mm 0.255 in.
Valve Lift
Exhaust 10.528 mm 0.4145 in.
Intake 10.350 mm 0.4075 in.
Intake Valve Timing
Opens 15.4° ± ½ BTDC
Closes 58° ± ½ ABDC
Exhaust Valve Timing
Opens 52.8 BBDC
Closes 26.2° ± ½ ATDC
Valve Overlap 41.6° ± ½
Intake Duration 253.3° ± ½
Exhaust Duration 259° ± ½
Crankshaft
End Play 0.038 - 0.165 mm 0.0015 - 0.0065 in.
Main Bearing Journal Diameter 63.489 - 63.502 mm 2.4996 - 2.5001 in.
Main Bearing Journal Width No. 1 27.58 - 27.89 mm 1.086 - 1.098 in.
Main Bearing Journal Width No. 2 32.28 - 32.33 mm 1.271 - 1.273 in.
Main Bearing Journal Width No. 3-4-5 30.02 - 30.18 mm 1.182 - 1.188 in.
Main Bearing Clearance 0.03 - 0.06 mm 0.001 - 0.0025 in.
Main Bearing Clearance (Preferred) 0.051 mm 0.002 in.
Connecting Rod Journal Diameter 53.17 - 53.23 mm 2.0934 - 2.0955 in.
Connecting Rod Journal Width 27.18 - 27.33 mm 1.070 - 1.076 in.
Out-of-Round (Max. All Journals) 0.013 mm 0.0005 in.
Taper (Max. -All Journals) 0.013 mm 0.0005 in.
Cylinder Block
Deck Height 236.73 mm 9.320 in.
Deck Clearance 0.000 mm 0.000 in.
Cylinder Bore Diameter-Standard 98.45 - 98.48 mm 3.8759 - 3.8775 in.
Cylinder Bore Diameter-Taper (Max.) 0.025 mm 0.001 in.
Cylinder Bore Diameter-Out-of-Round (Max.) 0.025 mm 0.001 in.
Tappet Bore Diameter 23.000 - 23.025 mm 0.9055 - 0.9065 in.
Flatness 0.03 mm per 25 mm 0.001 in. per 1 in.
0.05 mm per 152 mm 0.002 in. per 6 in.
Flatness Max. 0.20 mm for total length 0.008 in. for total length
Main Bearing Bore Diameter 68.3514 - 68.3768 mm 2.691 - 2.692 in.
Connecting Rods
Total Weight (Less Bearing) 657 - 665 grams 23.17 - 23.45 oz.
Length (Center-to-Center) 155.52 - 155.62 mm 6.123 - 6.127 in.
Piston Pin Bore Diameter 23.59 - 23.62 mm 0.9288 - 0.9298 in.
Bore (Less Bearings) 56.08 - 56.09 mm 2.2080 - 2.2085 in.
Bearing Clearance (Preferred) 0.044 - 0.050 mm 0.0015 - 0.0020 in.
Side Clearance 0.25 - 0.48 mm 0.010 - 0.019 in.
Twist (Max.) 0.001 mm per mm 0.001 in. per inch
Bend (Max.) 0.001 mm per mm 0.001 in. per inch.
Cylinder Compression Pressure
Ratio. 9.1:1
Pressure Range 827 - 1034 kPa 120 - 150 psi
Max. Variation Between Cylinders 206 kPa 30 psi
Cylinder Head Combustion Chamber 49.9 - 52.9 cc 3.04 - 3.23 cu. in.
Valve Guide I.D. (Integral) 7.95 - 7.97 mm 0.313 - 0.314 in.
Valve Stem-to-Guide Clearance 0.025 - 0.076 mm 0.001 - 0.003 in.
Intake Valve Seat Angle 44.5° ± ½

Exhaust Valve Seat Angle 44.5° ± ½

Valve Seat Width 1.01 - 1.52 mm 0.040 - 0.060 in.

Valve Seat Runout 0.064 mm 0.0025 in.

Rocker Arm Ratio 1.6:1

Push Rod Length 241.300 - 241.808 mm 9.500 - 9.520 in.

Push Rod Diameter 7.92 - 8.00 mm 0.312 - 0.315 in.

Hydraulic Tappet Diameter 22.962 - 22.974 mm 0.904 - 0.9045 in.

Tappet-to-Bore Clearance 0.025 - 0.063 mm 0.001 - 0.0025 in.

Valves

Length (Tip-to-Gauge Dimension Line) - Intake 124.435 - 125.070 mm 4.899 - 4.924 in.

Length (Tip-to-Gauge Dimension Line) - Exhaust 125.120 - 125.755 mm 4.927 - 4.952 in.

Valve Stem Diameter 7.899 - 7.925 mm 0.311 - 0.312 in.

Stem-to-Guide Clearance 0.025 - 0.076 mm 0.001 - 0.003 in.

Valve Head Diameter - Intake 48.387 - 48.641 mm 1.905 - 1.915 in.

Valve Head Diameter - Exhaust 37.973 - 38.227 mm 1.495 - 1.505 in.

Valve Face Angle - Intake 45° ± ½

Valve Face Angle - Exhaust 45° ± ½

Tip Refinishing (Max. Allowable) 0.25 mm 0.010 in.

Valve Springs

Free Length (Approx.) 47.65 mm 1.876 in.

Spring Tension - Valve Closed 271 - 307 N @ 41.656 mm 61 - 69 lbf. @ 1.64 in.

Spring Tension - Valve Open 818.5 - 871.9 N @ 30.89 mm 184 - 196 lbf @ 1.216 in.

Inside Diameter 21.0 mm - 21.51 mm 0.827 - 0.847 in.

Installed Height 41.656 mm 1.640 in.

Pistons

Weight (Less Pin) 417 - 429 grams 14.7 - 15.1 oz.

Piston Pin Bore (Centerline to Piston Top) 40.61 - 40.72 mm 1.599 - 1.603 in.

Piston-to-Bore Clearance 0.018 - 0.038 mm 0.0008 - 0.0015 in.

Piston Ring Groove Height - Compression Rings 1.530 - 1.555 mm 0.0602 - 0.0612 in.

Piston Ring Groove Height - Compression Rings 4.035 - 4.060 mm 0.1589 - 0.1598 in.

Piston Ring Groove Diameter - Compression Ring #1 88.39 - 88.65 mm 3.48 - 3.49 in.

Piston Ring Groove Diameter - Compression Ring # 2 87.63 - 87.88 mm 3.45 - 3.4599 in.

Piston Ring Groove Diameter - Oil Control Ring 89.66 - 89.92 mm 3.53 - 3.54 in.

Piston Pin Bore Diameter 23.650 - 23.658 mm 0.9312 - 0.9315 in.

Piston Pin Diameter 23.637 - 23.640 mm 0.9306 - 0.9307 in.

Piston-to-Pin Clearance 0.0102 - 0.0208 mm 0.0005 - 0.0009 in.

Piston-to-Pin Connecting Rod (Press Fit) 8.9 kN 2000 lbf.

Piston Rings

Ring Gap Clearance - Top Compression Ring 0.229 - 0.610 mm 0.0090 - 0.0240 in.

Ring Gap Clearance - 2nd Compression Ring 0.483 - 0.965 mm 0.0190 - 0.0380 in.

Ring Gap Clearance - Oil Control Steel Rails 0.254 - 1.500 mm 0.010 - 0.060 in.

Ring Side Clearance - Compression Ring 0.042 - 0.084 mm 0.0017 - 0.0033 in.

Ring Side Clearance - Oil Control Ring 0.06 - 0.21 mm 0.0024 - 0.0083 in.

Oil Pump

Gear-to-Body Clearance (Radial) 0.051 - 0.102 mm 0.002 - 0.004 in.

Gear-to-Body Clearance (Radial)

(Preferred) 0.051 mm 0.002 in.

Gear End Clearance - Plastigage 0.051 - 0.152 mm 0.002 - 0.006 in.

Gear End Clearance - Plastigage

Gear End Clearance - Feeler Gauge 0.1016 - 0.2032 mm 0.004 - 0.008 in.

Gear End Clearance - Feeler Gauge

(Preferred) 0.1778 mm 0.007 in.

Oil Pressure

Min. Pressure (600 rpm) 89.6 kPa 13 psi

At Idle Speed (800 rpm) 172 - 241 kPa 25 - 35 psi

At 1600 rpm & Higher 255 - 517 kPa 37 - 75 psi

Oil Pressure Relief 517 kPa 75 psi

Tightening Specifications (Article 2038541)

DESCRIPTION TORQUE

A/C Compressor Bracket-to-Engine Bolts 34 N.m 25 ft. lbs.
A/C Compressor Mounting Bolts 27 N.m 20 ft. lbs.
Block Heater Nut 1.8 N.m 16 in. lbs.
Camshaft Sprocket Bolt 108 N.m 80 ft. lbs.
Clutch Cover to Flywheel Bolts 31 N.m 23 ft. lbs.
Connecting Rod Nuts 45 N.m 33 ft. lbs.
Cylinder Block Drain Plugs 41 N.m 30 ft. lbs.
Cylinder Head Bolts Torque Sequence

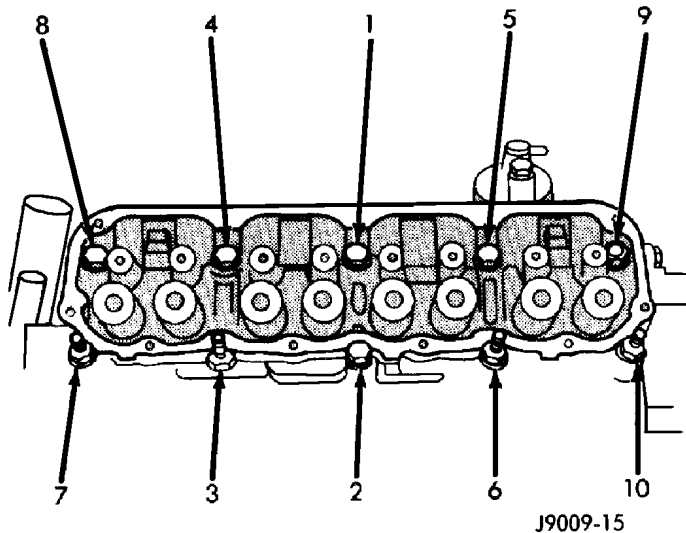

Fig. 51 Engine cylinder head Bolt Tightening Sequence

Cylinder Head Bolts (#1-10 & #12-14) 149 N.m 110 ft. lbs.
Cylinder Head Bolt (#11) 135 N.m 100 ft. lbs.
Cylinder Head Cover Bolts 13 N.m 115 in. lbs.
Dipstick Tube Bracket to Cylinder Block Bolts 19 N.m 168 in. lbs.
Distributor Hold-Down Clamp Bolt 23 N.m 204 in. lbs.
Engine Mounts-Front
Insulator Bracket Bolts 81 N.m 60 ft. lbs.
Insulator Bracket Nuts 47 N.m 35 ft. lbs.
Insulator Thru-Bolt 81 N.m 60 ft. lbs.
Engine Mounts-Rear
Support Cushion/Crossmember Nuts 22 N.m 192 in. lbs.
Support Cushion/Bracket Nuts 46 N.m 34 ft. lbs.
Transmission Support Bracket Bolts 43 N.m 32 ft. lbs.
Transmission Support Bracket/Cushion Bolt 75 N.m 55 ft. lbs.
Transmission Support Adaptor Bracket Bolt 75 N.m 55 ft. lbs.
Exhaust Manifold /Pipe Nuts 27 N.m 20 ft. lbs.
Flywheel/Converter Housing Bolts 38 N.m 28 ft. lbs.
Flywheel to Crankshaft Bolts 143 N.m 105 ft. lbs.
Front Cover to Block Bolts (1/4-20) 7 N.m 60 in. lbs.
Front Cover to Block Bolts (5/16-18) 22 N.m 1.192 in. lbs.
Generator Adjusting Bolt 24 N.m 18 ft. lbs.
Generator Pivot Bolt/Nut 38 N.m 28 ft. lbs.
Mounting Bracket-to-Engine Bolts 38 N.m 28 ft. lbs.
Mounting/Head Bolts 45 N.m 33 ft. lbs.
Main Bearing Bolts 108 N.m 80 ft. lbs.
Oil Filter Adaptor Bolt 102 N.m 75 ft. lbs.
Oil Filter Connector 68 N.m 50 ft. lbs.
Oil Filter 18 N.m 13 ft. lbs.
Oil Galley Plug 41 N.m 30 ft. lbs.

Oil Pan Bolts (1/4-20) 9.5 N.m 84 in. lbs.
Oil Pan Bolts (5/16-18) 15 N.m 132 in. lbs.
Oil Pan Drain Plug 34 N.m 25 ft. lbs.
Oil Pressure Sending Unit 15 N.m 130 in. lbs.
Oil Pump Attaching Bolts (Short) 23 N.m 204 in. lbs.
Oil Pump Attaching Bolts (Long) 23 N.m 204 in. lbs.
Oil Pump Cover Bolts 8 N.m 70 in. lbs.
Power Steering Pump Pressure Hose Nut 52 N.m 38 ft. lbs.
Rocker Arm Assembly to Cylinder Head Capscrews 28 N.m 21 ft. lbs.
Spark Plugs 37 N.m 27 ft. lbs.
Starter Motor Mounting Bolts 45 N.m 33 ft. lbs.
Tensioner Bracket to Cylinder Block Bolts 19 N.m 168 in. lbs.
Thermostat Housing Bolts 18 N.m 156 in. lbs.
Throttle Body Bolts 10 N.m 90 in. lbs.
Vibration Damper Bolt 108 N.m 80 ft. lbs.
Water Pump to Block Bolts 31 N.m 23 ft. lbs.

All Technical Service Bulletins (itype_100)

Tsbs

- Recall - Spark Plug Defect (8061, 1998/12/01)
- Recall - Spark Plugs (8062, 1998/12/01)

General Information (Article 2047375)

GENERAL INFORMATION

Engine diagnosis is helpful in determining the causes of malfunctions not detected and remedied by routine maintenance.

These malfunctions may be classified as either performance (e.g., engine idles rough and stalls) or mechanical (e.g., a strange noise). Information concerning additional tests and diagnosis is provided within the following diagnosis:

^ Cylinder

Compression Pressure

Test.

^ Cylinder Combustion Pressure Leakage Test.

^ Engine

Cylinder Head Gasket

Failure Diagnosis.

^

Intake Manifold

Leakage Diagnosis.

Diagnosis and Testing Procedures (Article 2047376)

Non Standards

- Checking For Oil Leaks (2047377)
- Cylinder Combustion Pressure Leakage Test (2047378)
- Cylinder Head Gasket Failure Diagnosis (2047383)
- Hydraulic Tappet Leakdown Test (2047384)
- Intake Manifold Leak Diagnosis (2047379)

Diagnosis By Symptom (Article 2047203)

Non Standards

- Engine Diagnosis-Mechanical (2047204)
- Engine Diagnosis-Performance (2047205)

Electrical / Mechanical Repair (itype_413)

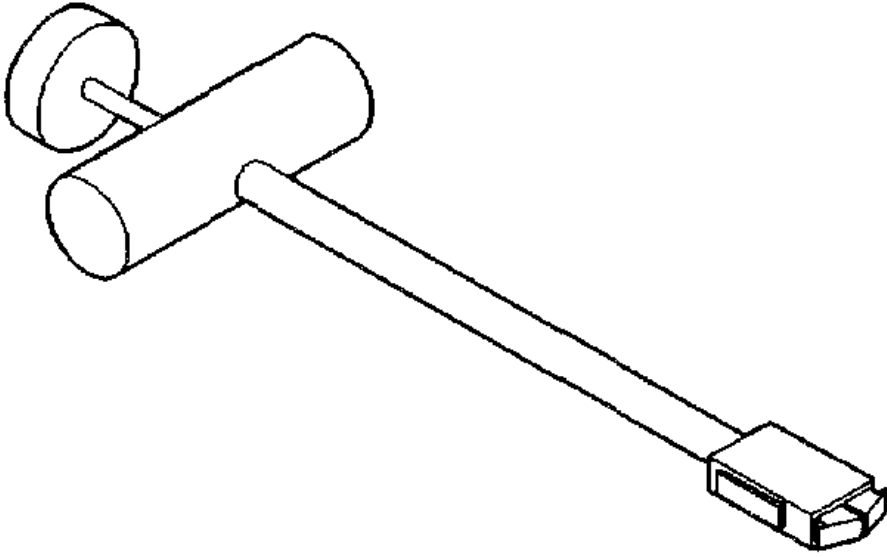
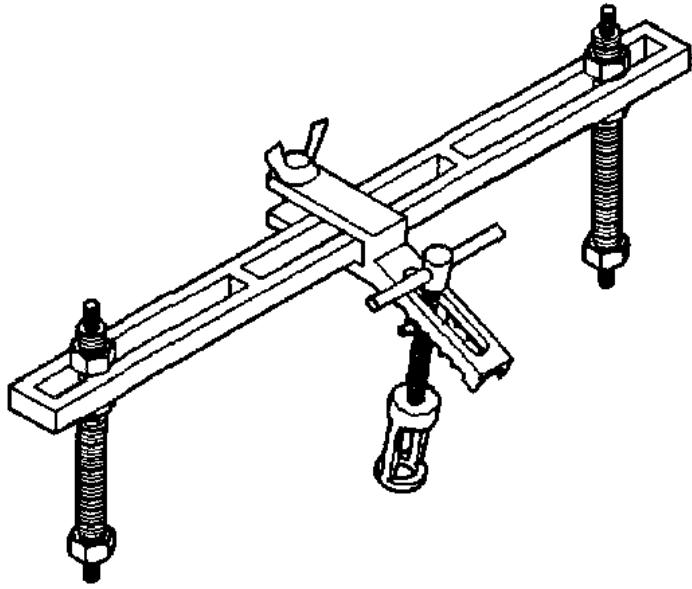

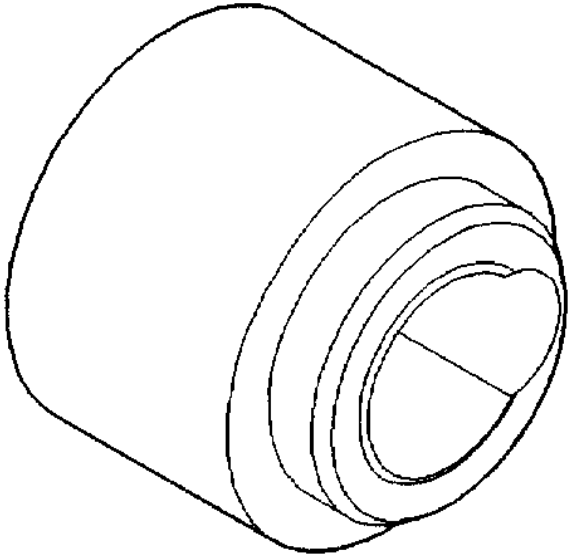
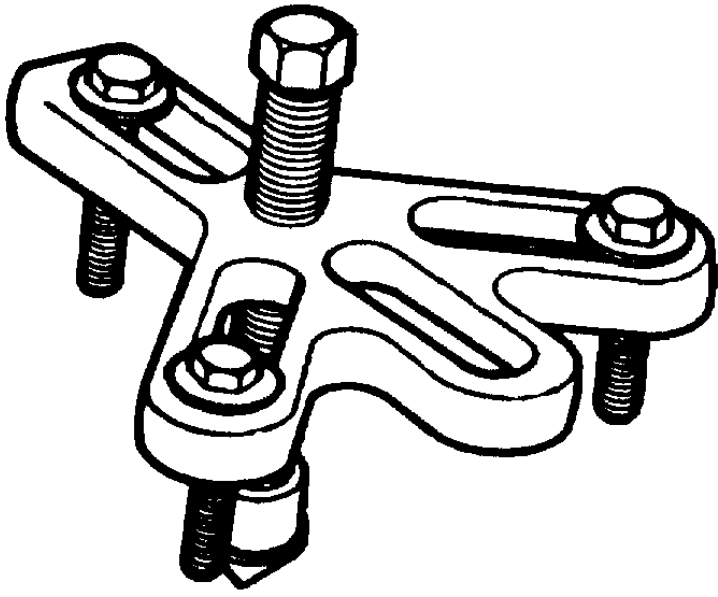

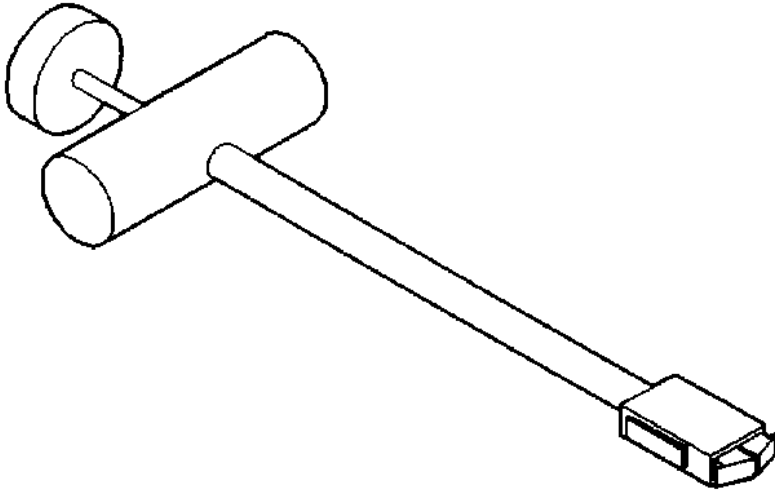

Emissions (itype_106)

Tsbs

- Recall - Spark Plug Defect (8061, 1998/12/01)
- Recall - Spark Plugs (8062, 1998/12/01)