

Component Procedures: Radiator

Table of Contents

1. Parts and Labor (itype_189)
2. Components (itype_392)
3. Procedures (itype_376)
4. Mechanical (including Torque) (itype_28)

Component Procedures: Radiator

Parts and Labor (itype_189)

Parts

Qualifier	Part #	Name	Price	Note
Radiator > Manual Trans	52080180AE	1 - Radiator	347.00	
Radiator > Auto Trans	52080181AF	1 - Radiator	350.00	

Labor

Operation	Qualifier Path	Skill	Std Hrs	Wty Hrs
Replace	Radiator, R&R	B	1.8	1.1

Components (itype_392)

RADIATOR

A heavy duty down-flow aluminum/plastic radiator is used. The radiator consists of an aluminum core and plastic end tanks, which are fastened to the core with clinch tabs and sealed with a high temperature rubber gasket. On automatic transmission equipped vehicles, the lower tank contains a concentric-tube transmission oil cooler.

CAUTION:

Plastic tanks, while stronger than brass, are subject to damage by impact, such as wrenches, mishandling, etc. If the plastic tank has been damaged, individual parts are not available, and the radiator must be replaced.

Procedures (itype_376)

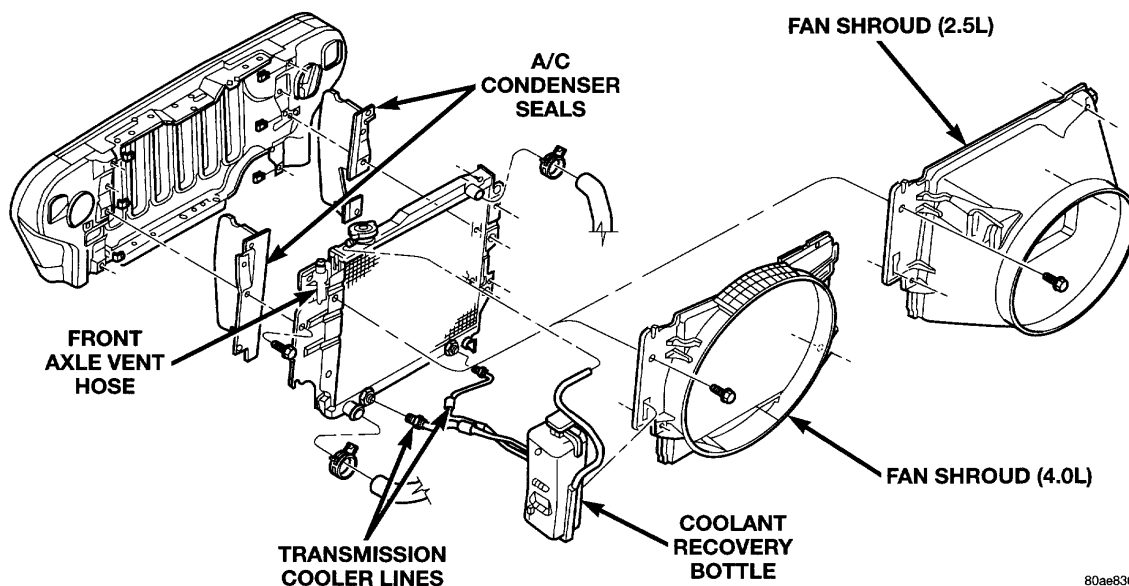

80ae8360

Mechanical (including Torque) (itype_28)

Radiator 72 in.lb