

# **Component Procedures: Shift Interlock**

## **Table of Contents**

1. Selector Cable Adjustment (Article 1367663)
2. Electrical (OE) (itype\_21)
3. Automatic Transaxle Shift Mechanism Location Index (Article 1368504)
4. All Technical Service Bulletins (itype\_100)
5. Customer Interest Bulletins (itype\_109)
6. Key Interlock Solenoid Inspection (Article 1358650)
7. Selector Lever Component Inspection (Article 1371376)
8. Selector Lever Inspection (Article 1371377)
9. Shift-Lock Inspection (Article 1367670)
10. Starting problems (itype\_171)
11. New / Updated Parts (itype\_117)

# Component Procedures: Shift Interlock

## Selector Cable Adjustment (Article 1367663)

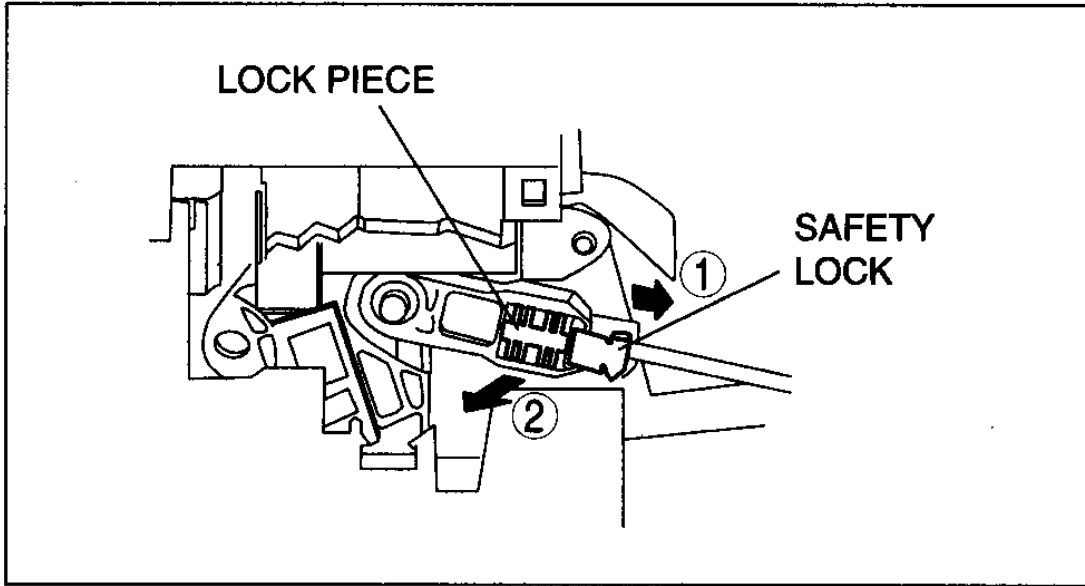

b3e0518w005

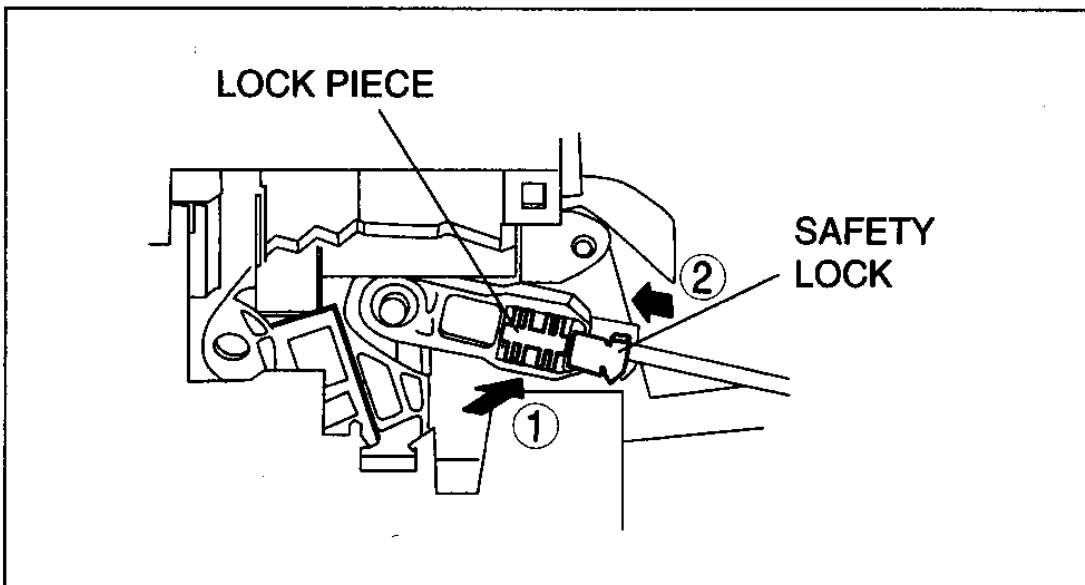

b3e0518w006

Electrical (OE) (itype\_21)

KEY INTERLOCK SYSTEM/SHIFT-LOCK SYSTEM

0518

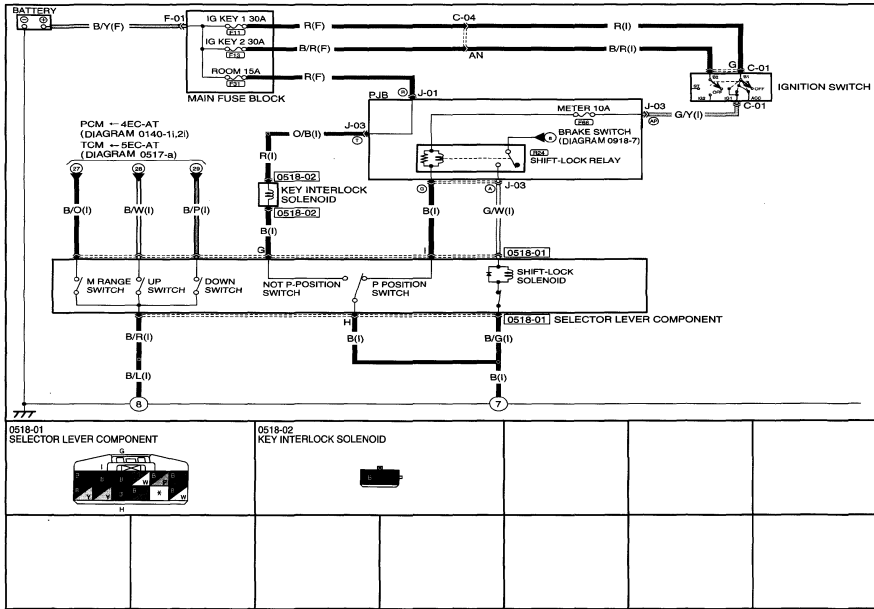

KEY INTERLOCK SYSTEM/SHIFT-LOCK SYSTEM

0518

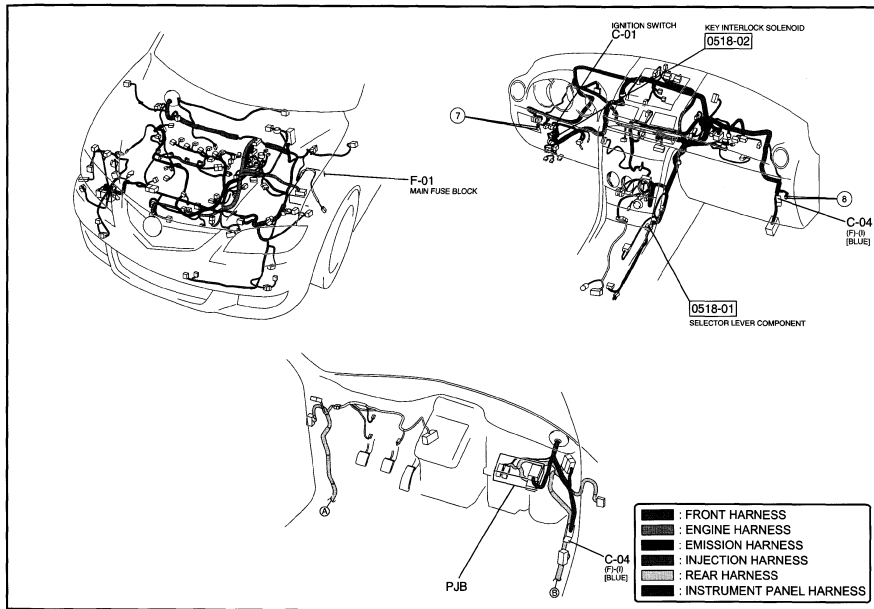

Automatic Transaxle Shift Mechanism Location Index (Article 1368504)

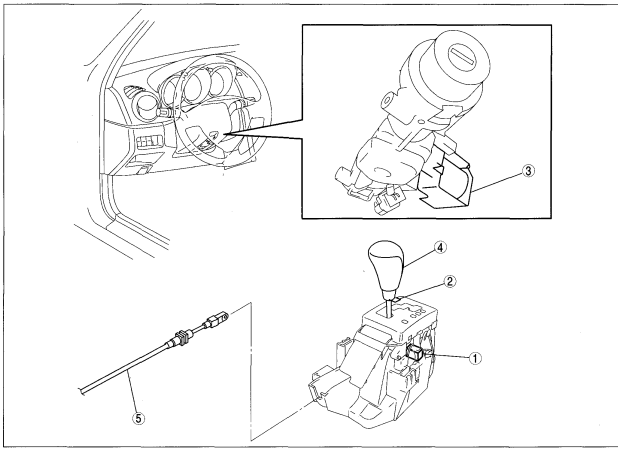

1	Shift-lock solenoid (See SHIFT-LOCK INSPECTION.) (See SHIFT-LOCK SOLENOID INSPECTION.)
2	Emergency override button (See EMERGENCY OVERRIDE BUTTON INSPECTION.)
3	Key interlock solenoid (See KEY INTERLOCK SOLENOID INSPECTION.)

4	Selector lever (See SELECTOR LEVER INSPECTION.) (See SELECTOR LEVER COMPONENT INSPECTION.) (See SELECTOR LEVER COMPONENT REMOVAL/INSTALLATION.) (See SELECTOR LEVER DISASSEMBLY/ASSEMBLY.)
5	Selector cable (See SELECTOR CABLE ADJUSTMENT.)

### All Technical Service Bulletins (itype\_100)

Tsbs

- A/T - Intermittent Engine No Start In PARK (0500212, 2012/02/29)

### Customer Interest Bulletins (itype\_109)

Tsbs

- A/T - Intermittent Engine No Start In PARK (0500212, 2012/02/29)

### Key Interlock Solenoid Inspection (Article 1358650)

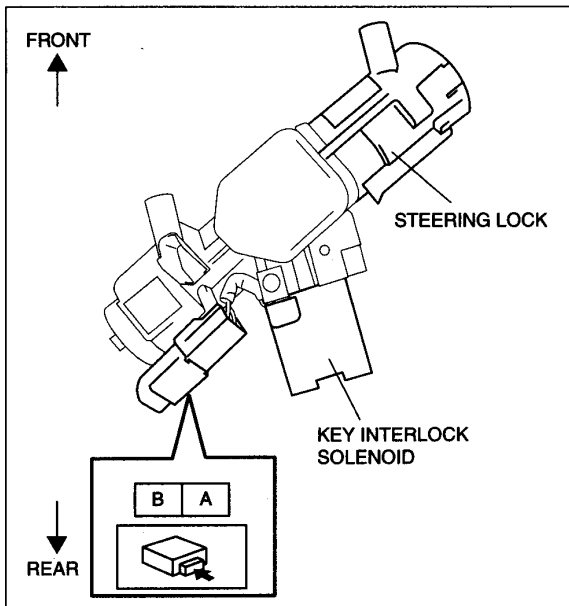

### Selector Lever Component Inspection (Article 1371376)

○—○ : Continuity

Selector lever position/range	Connector terminal												
	A	B	C	D	E	F	G	H	I	J	K	L	
M range - M			○									○	
M range Center M	○											○	
M range + M		○										○	
P position									○	○			
Except P position							○	○					

C3U0518W002

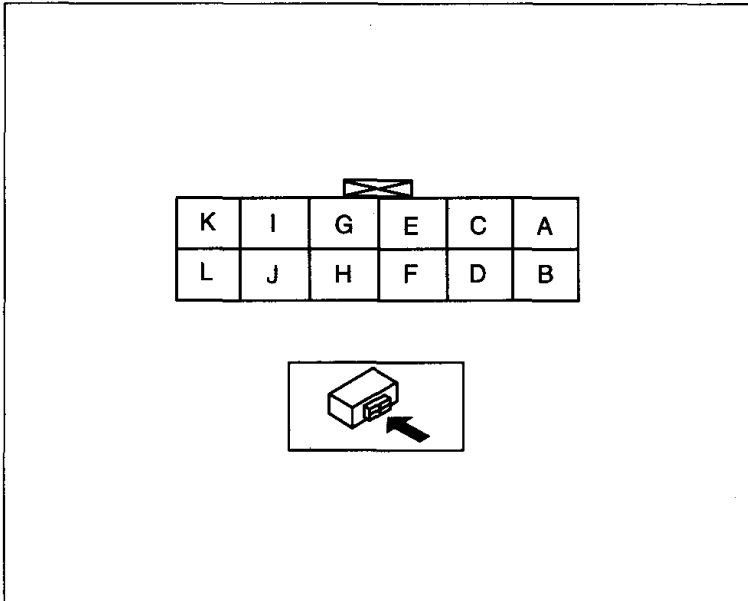

B3E0518W003

### Selector Lever Inspection (Article 1371377)

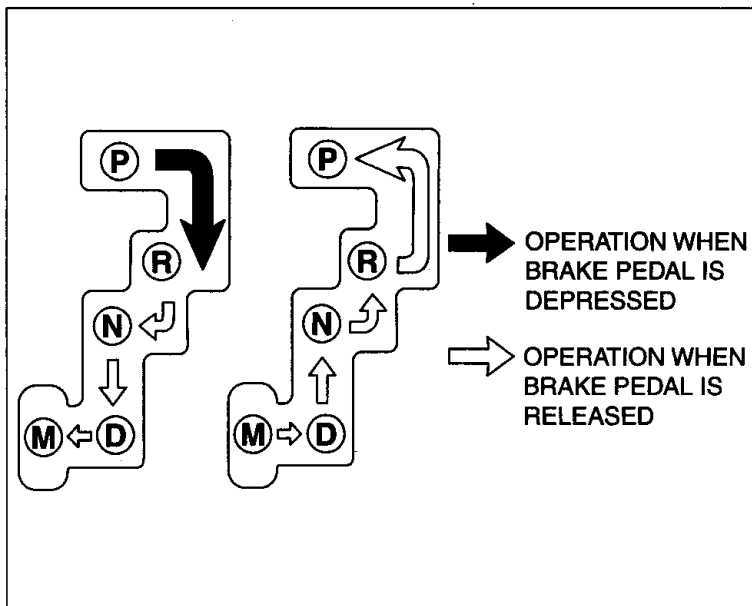

chu0514w002

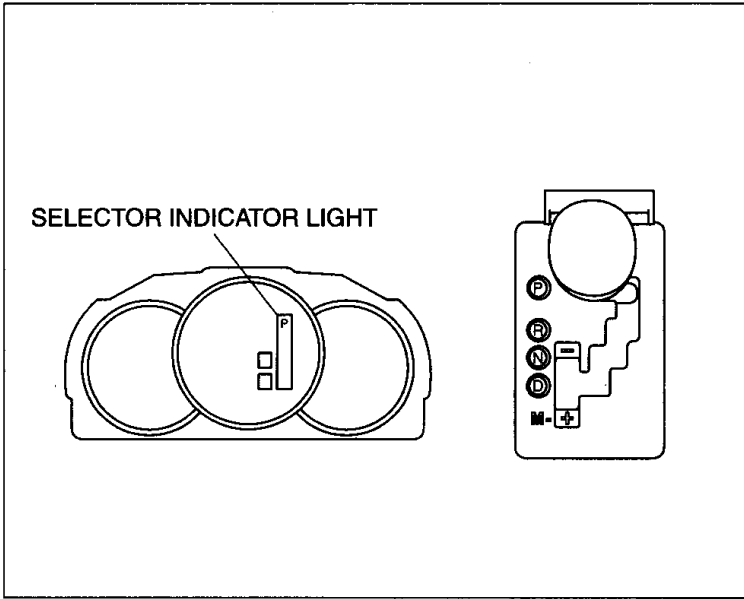

B3E0518W002

### Shift-Lock Inspection (Article 1367670)

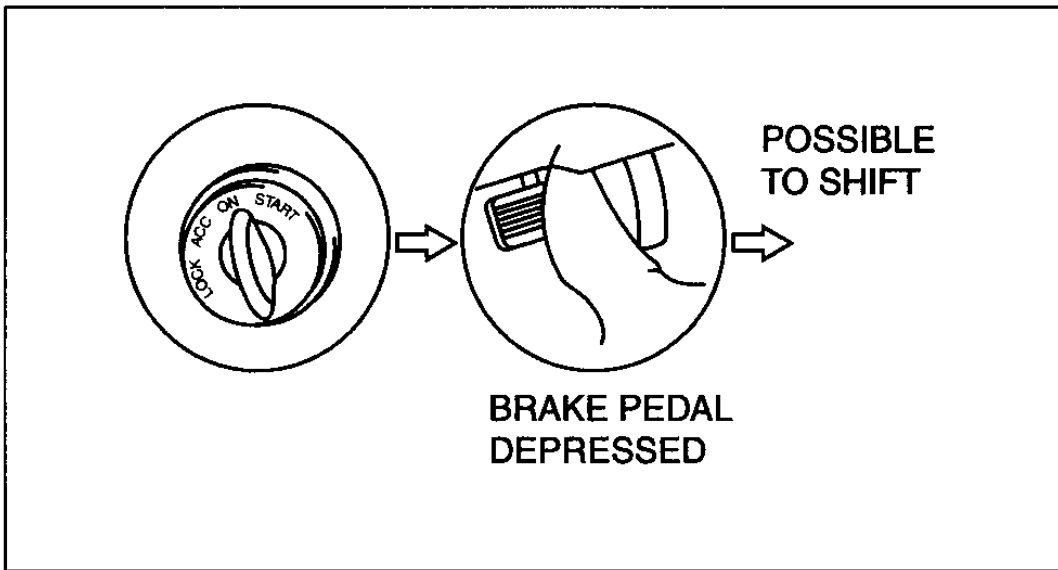

C3U0518W004

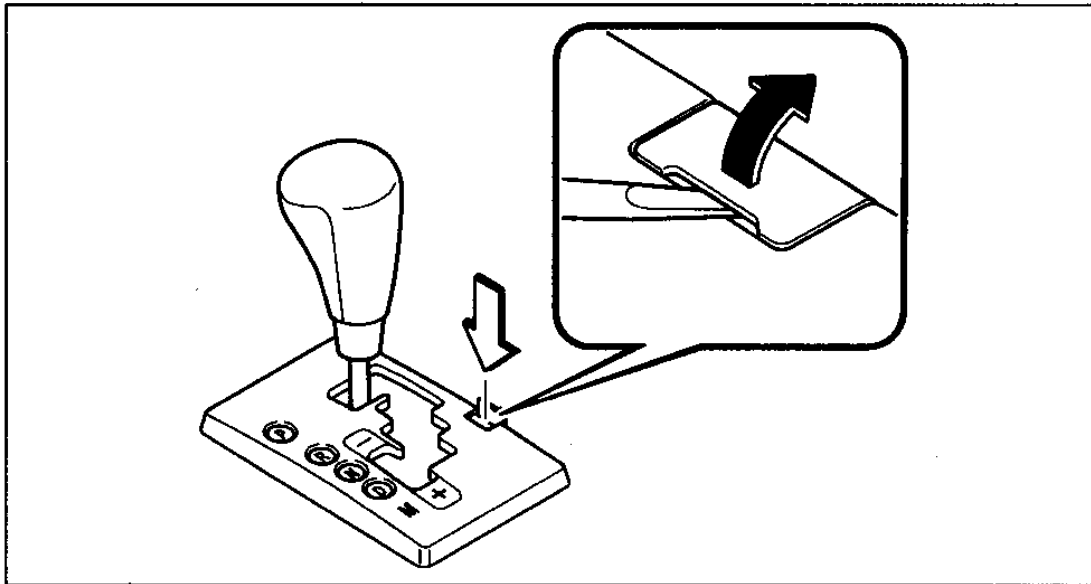

c3u0518w001

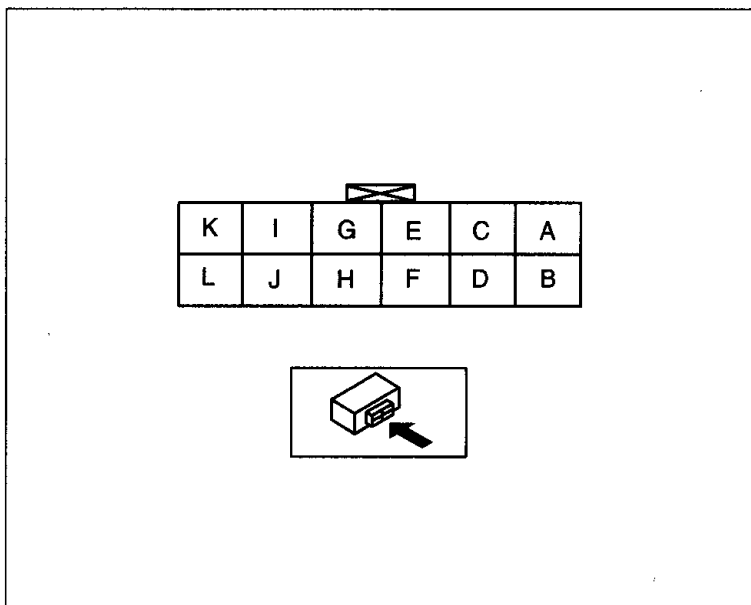

B3E0518W003

**Starting problems (itype\_171)**

Tsbs

- A/T - Intermittent Engine No Start In PARK (0500212, 2012/02/29)

**New / Updated Parts (itype\_117)**

Tsbs

- A/T - Intermittent Engine No Start In PARK (0500212, 2012/02/29)