

Component Procedures: Front Steering Knuckle

Table of Contents

1. Parts and Labor (itype_189)
2. Removal and Replacement (itype_401)

Component Procedures: Front Steering Knuckle

Parts and Labor (itype_189)

Parts

Qualifier	Part #	Name	Price	Note
Front Suspension > Knuckle > ?	BAK633021	2 - Knuckle	0.00	
Front Suspension > Knuckle > ?	BAK633031	2 - Knuckle	149.70	
Front Suspension > Knuckle > ?	BR5S33021	2 - Knuckle	0.00	
Front Suspension > Knuckle > ?	BR5S33031	2 - Knuckle	237.25	

Labor

Operation	Qualifier Path	Skill	Std Hrs	Wty Hrs
Replace	Front Suspension > Knuckle > One Side	B	1.6	1.2
Replace	Front Suspension > Knuckle > Both Sides	B	2.8	1.8

Removal and Replacement (itype_401)

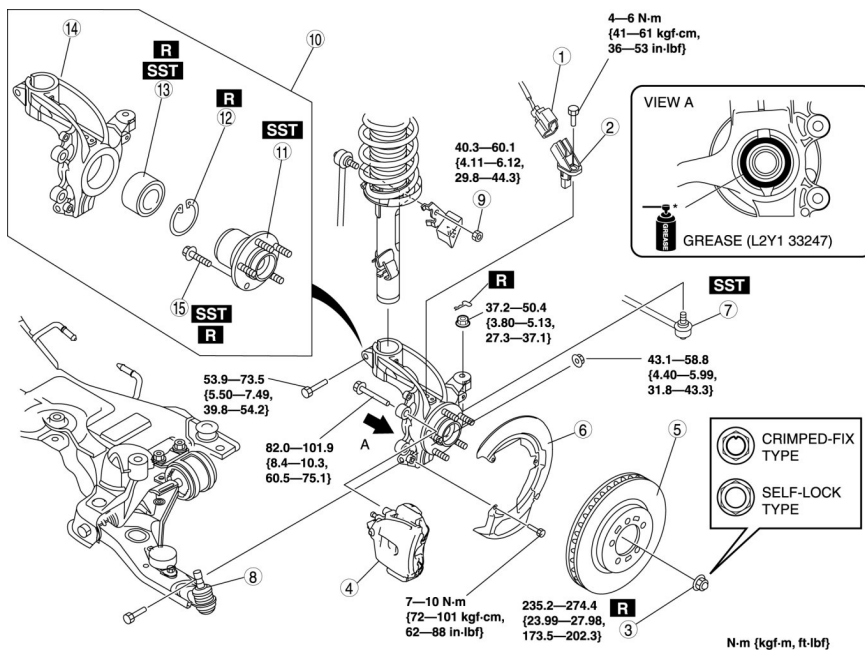

1	ABS wheel-speed sensor connector
2	ABS wheel-speed sensor
3	Locknut (crimped-fix type)/Locknut (self-lock type) (See Locknut (Crimped-fix Type) Removal Note.) (See Locknut (Crimped-fix Type) Installation Note.)
4	Brake caliper component (See Brake Caliper Removal Note.)
5	Disc plate (See FRONT BRAKE (DISC) REMOVAL/INSTALLATION[L,F, L3].) (See FRONT BRAKE (DISC) REMOVAL/INSTALLATION[L3 WITH TC].)
6	Dust cover
7	Tie-rod end ball joint (See FRONT CROSSMEMBER REMOVAL/INSTALLATION.)
8	Front lower arm ball joint
9	Stabilizer control link upper nut
10	Wheel hub, steering knuckle component (See Wheel Hub, Steering Knuckle Component Removal Note.) (See Wheel Hub, Steering Knuckle Component Installation Note.)
11	Wheel hub component (See Wheel Hub Component Removal Note.) (See Wheel Hub Component Installation Note.)
12	Retaining clip
13	Wheel bearing (See Wheel Bearing Removal Note.) (See Wheel Bearing Installation Note.)
14	Steering knuckle
15	Hub bolt (See Wheel Hub Bolt Removal Note.) (See Wheel Hub Bolt Installation Note.)

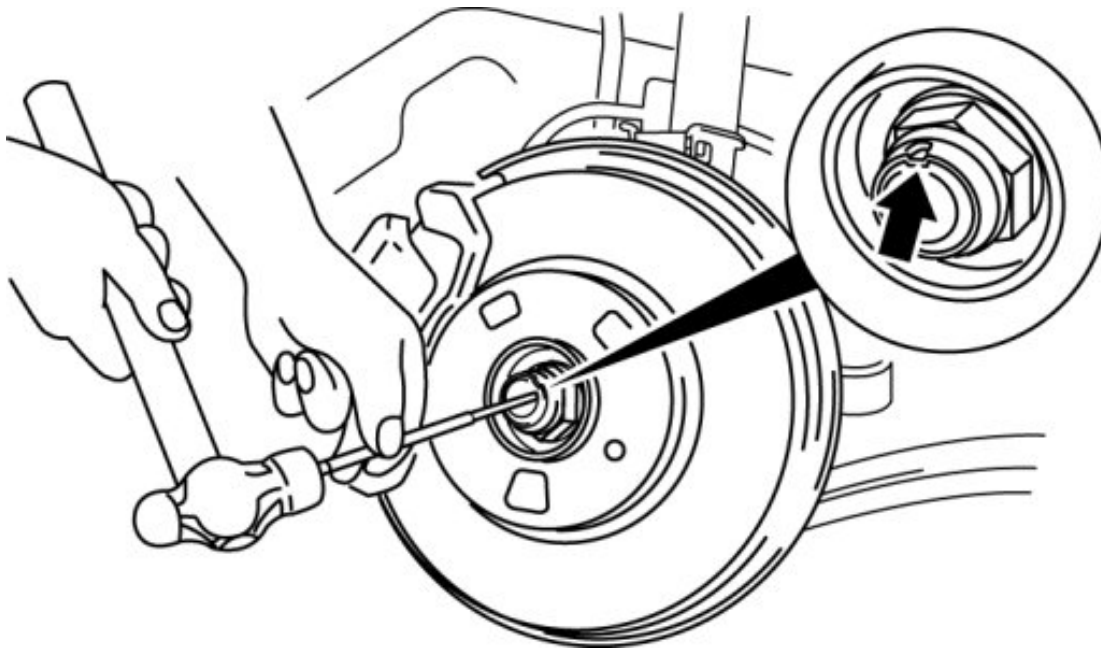

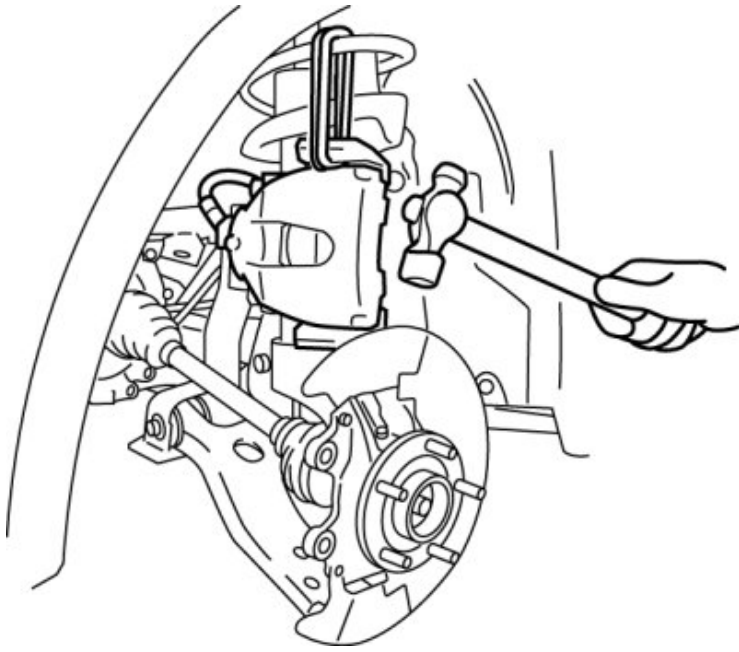
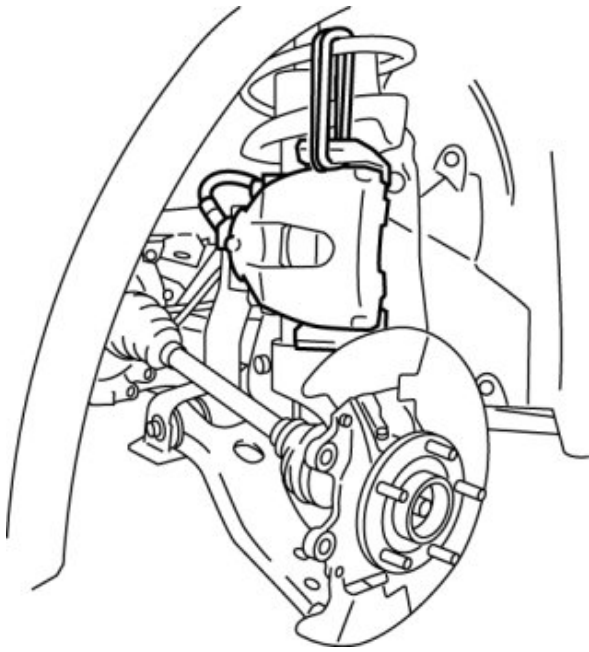

49 G033 102

49 G033 105

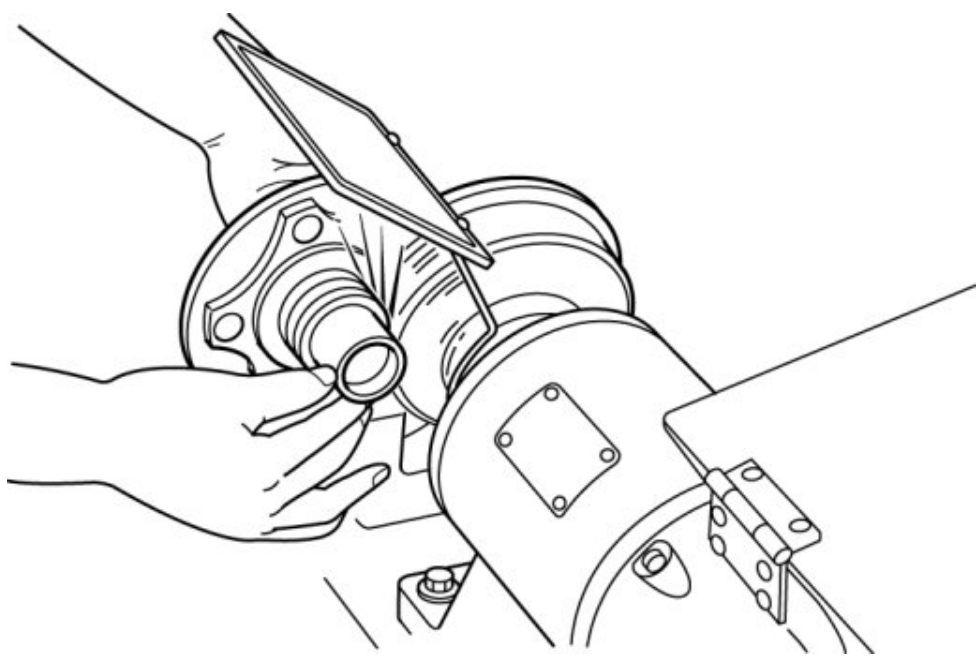
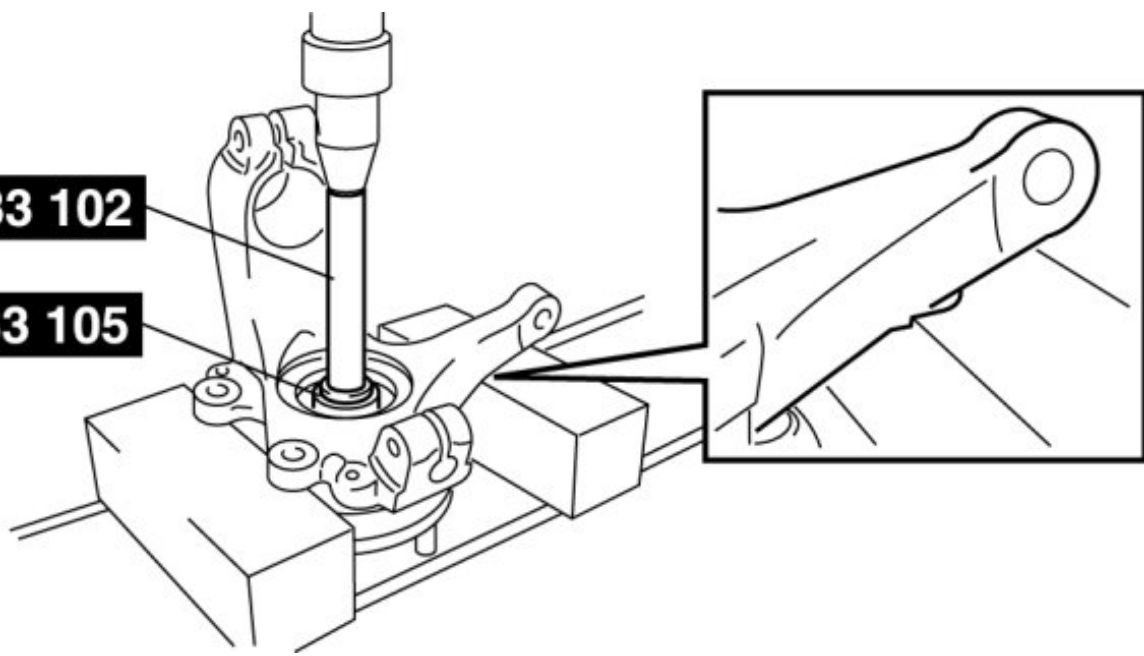

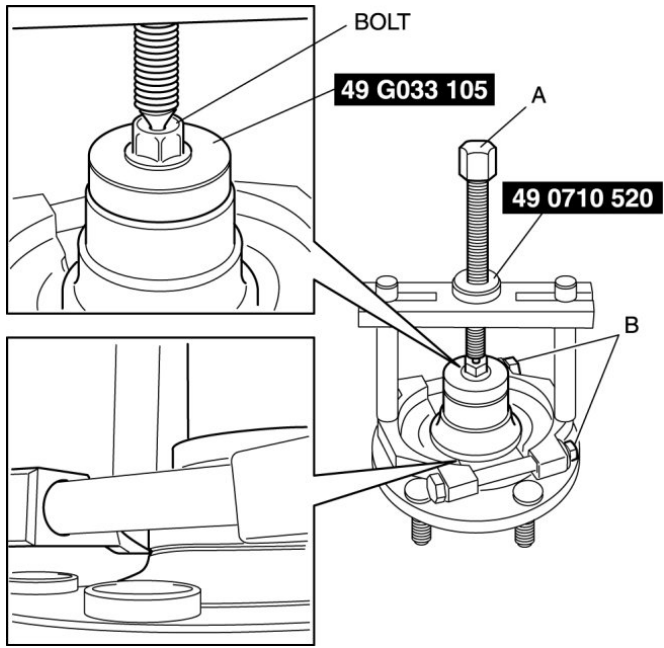
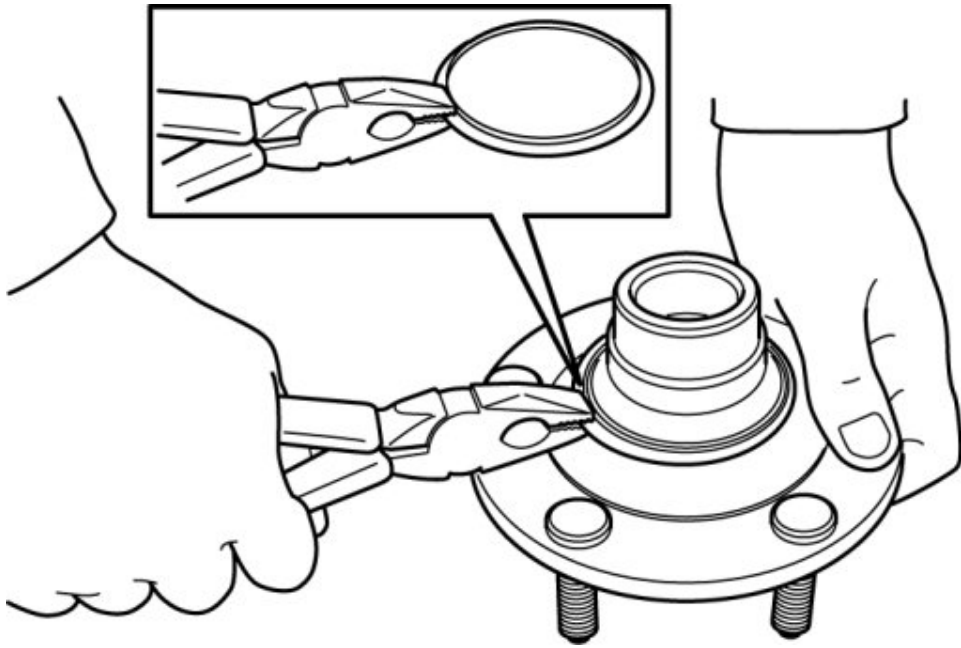

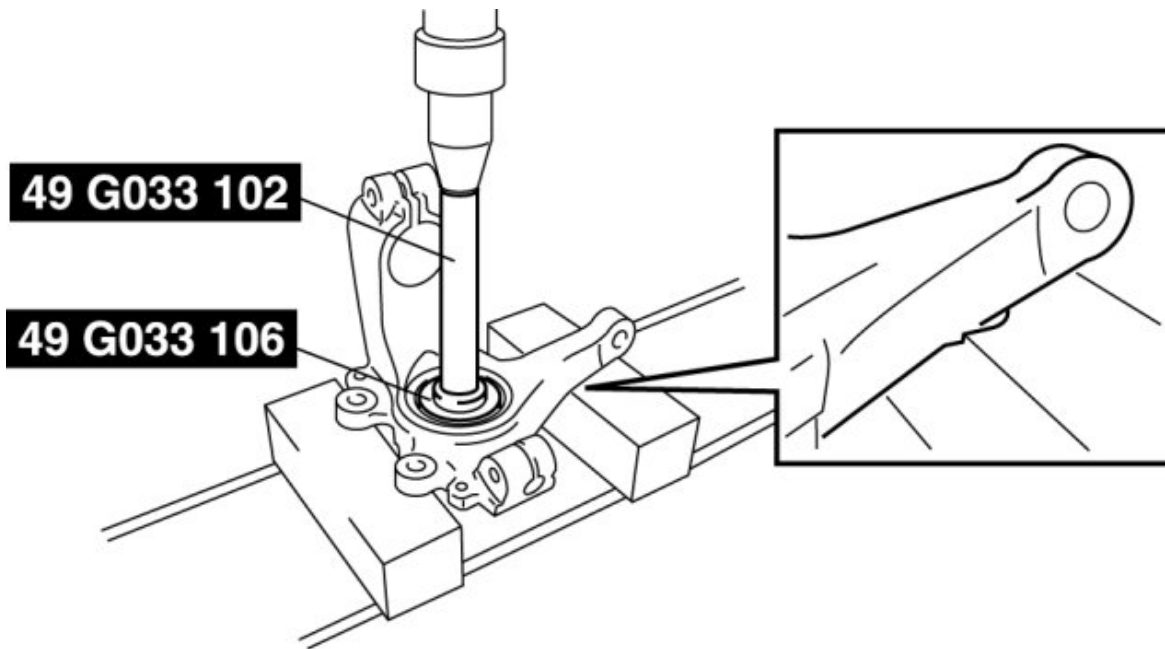
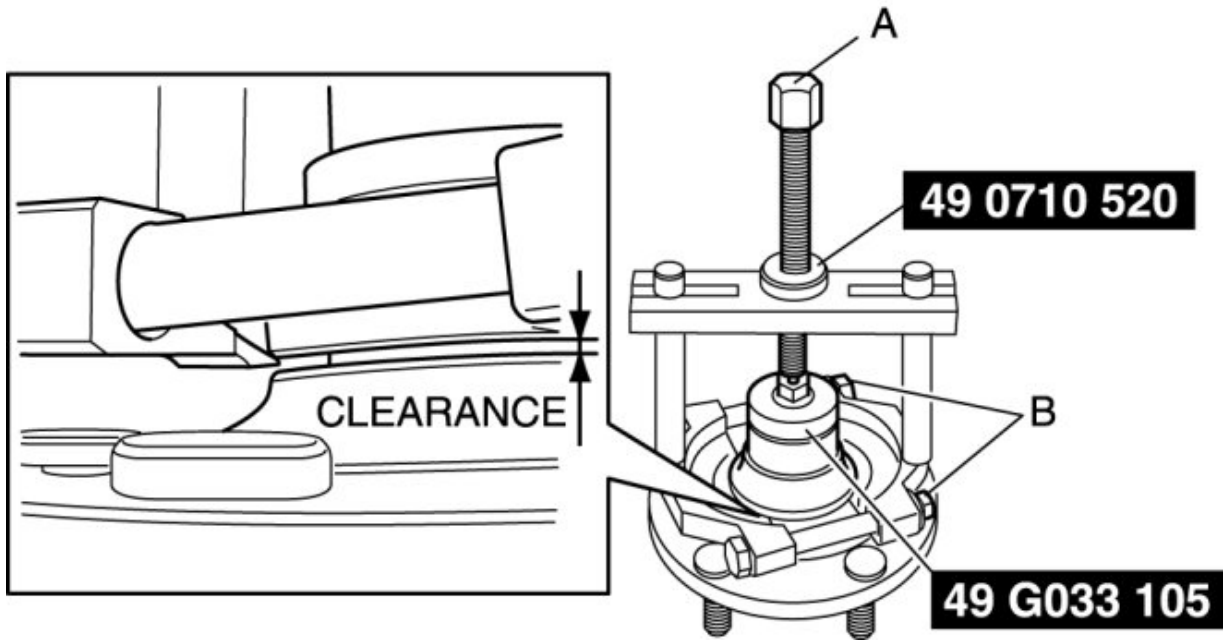

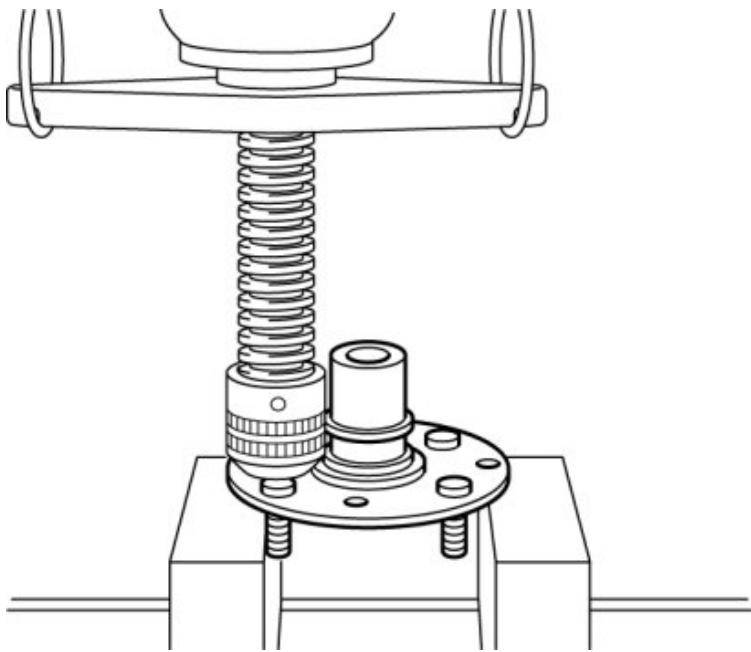
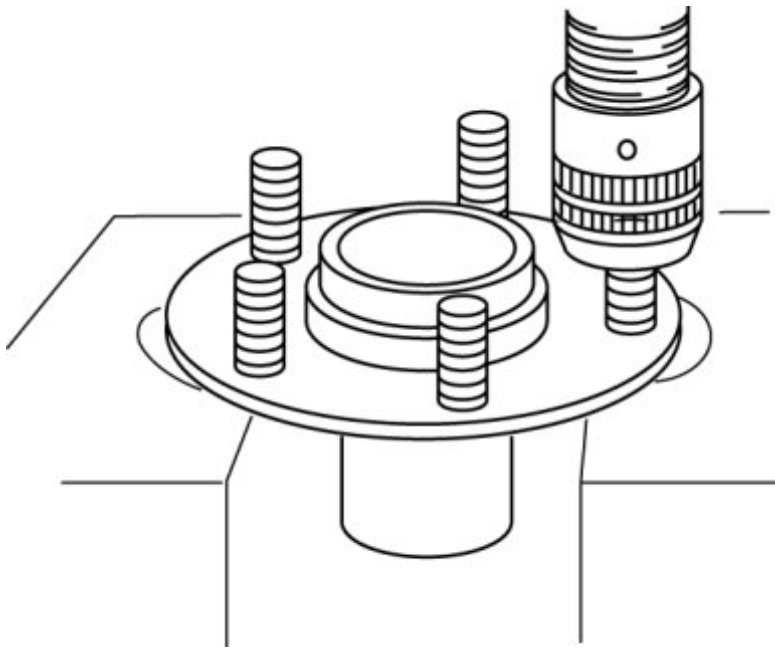

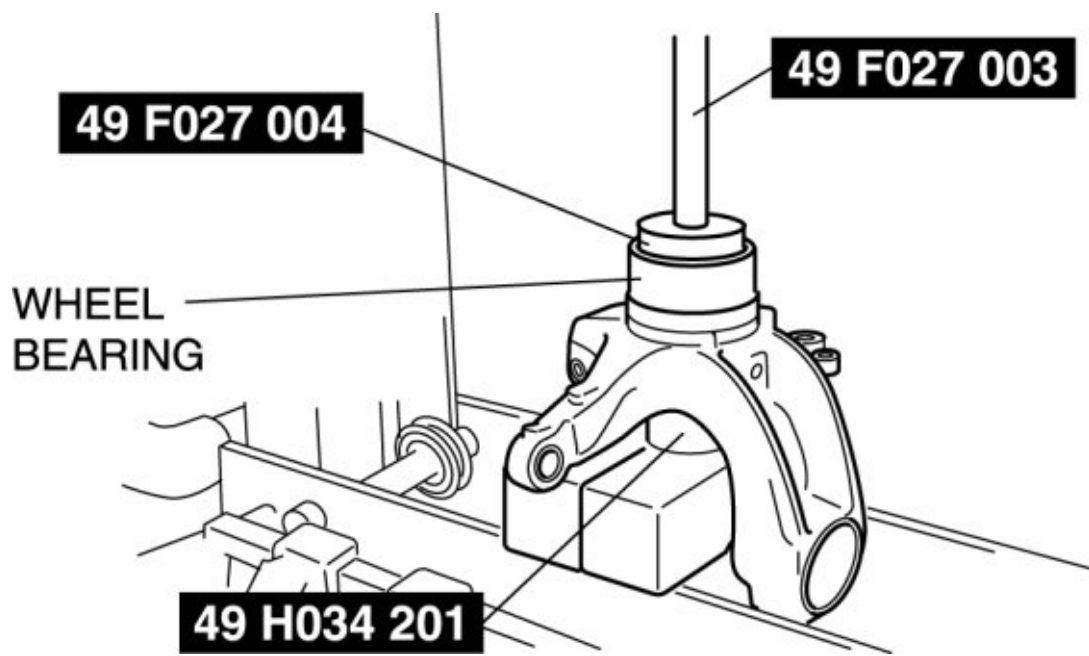
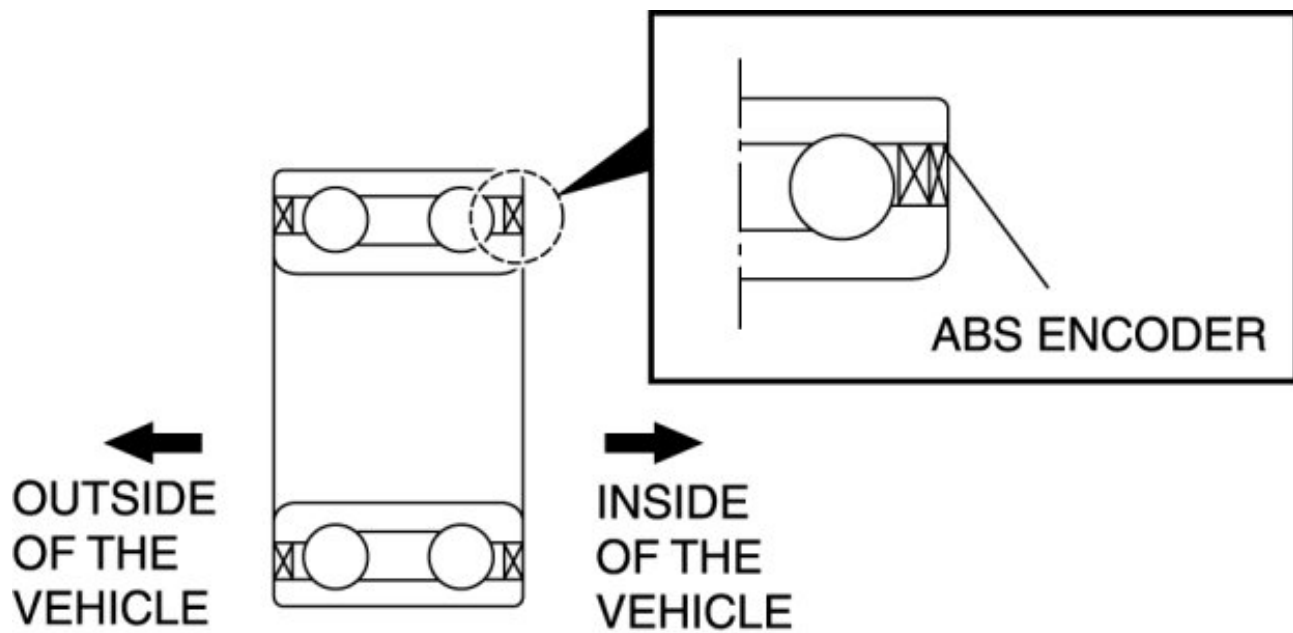

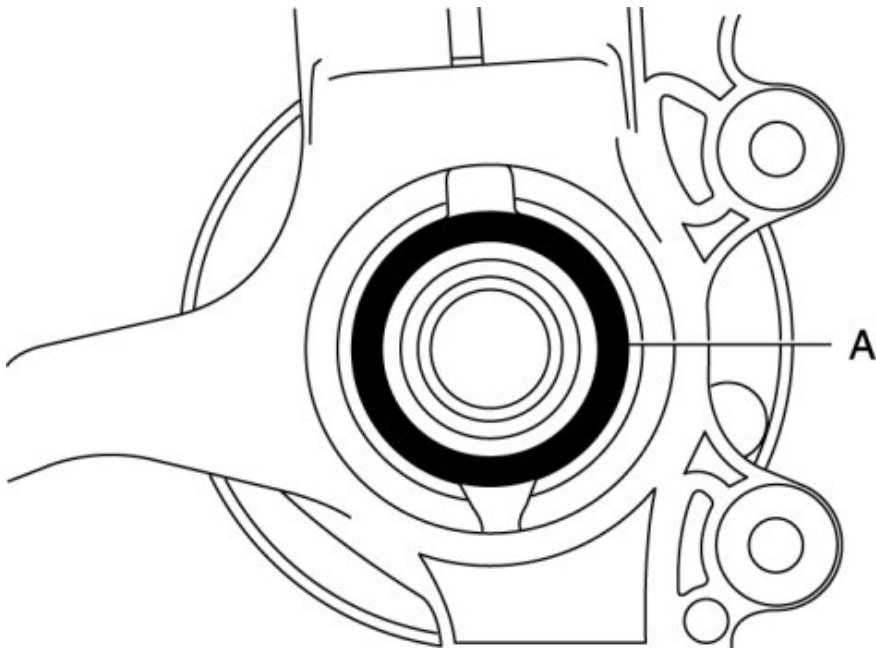
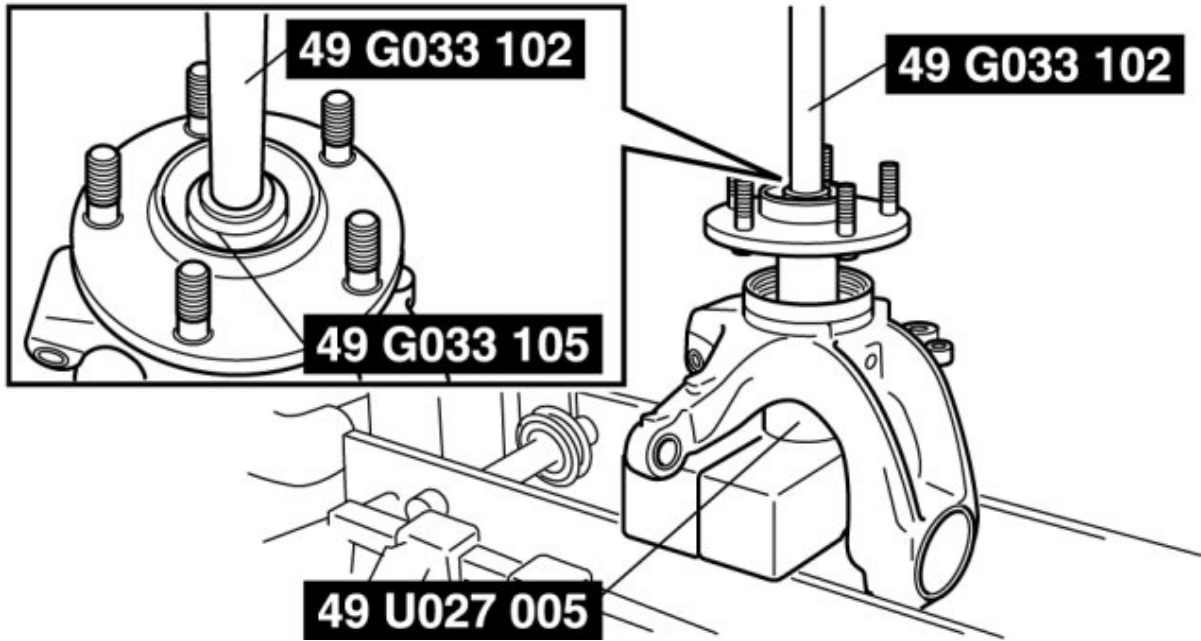

0.5 mm{0.02in} OR MORE

