

Component Procedures: Housing Assembly HVAC

Table of Contents

1. A/C Unit Disassembly/Assembly [Full-Auto Air Conditioner] (Article 1393191)
2. A/C Unit Disassembly/Assembly [Manual Air Conditioner] (Article 1393192)
3. Removal and Replacement (itype_401)

Component Procedures: Housing Assembly HVAC

A/C Unit Disassembly/Assembly [Full-Auto Air Conditioner] (Article 1393191)

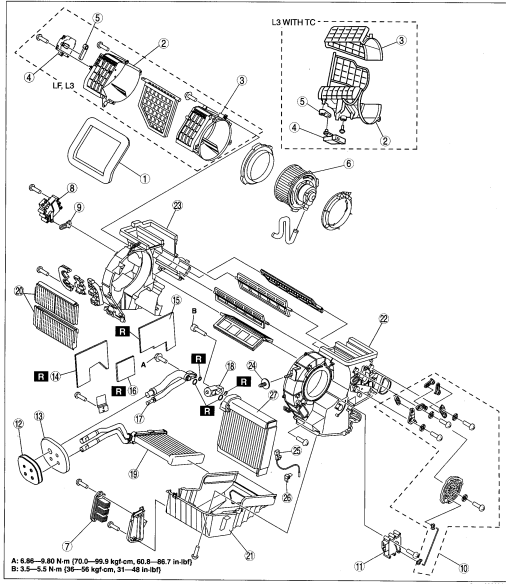

1	Adhesive polyurethane (1)	3	Blower case (2)
2	Blower case (1)	4	Air intake actuator

5	Air intake link set
6	Blower motor
7	Power MOS FET
8	Air mix actuator
9	Air mix link set
10	Airflow mode link set
11	Airflow mode actuator
12	Polyurethane foam (1)
13	Polyurethane foam (2)
14	Adhesive polyurethane (2)
15	Adhesive polyurethane (3)
16	Adhesive polyurethane (4)

17	Evaporator pipe
18	Expansion valve
19	Heater core
20	Air filter
21	A/C case (3)
22	A/C case (1)
23	A/C case (2)
24	Bolt
25	Evaporator temperature sensor
26	Sensor clamp
27	Evaporator

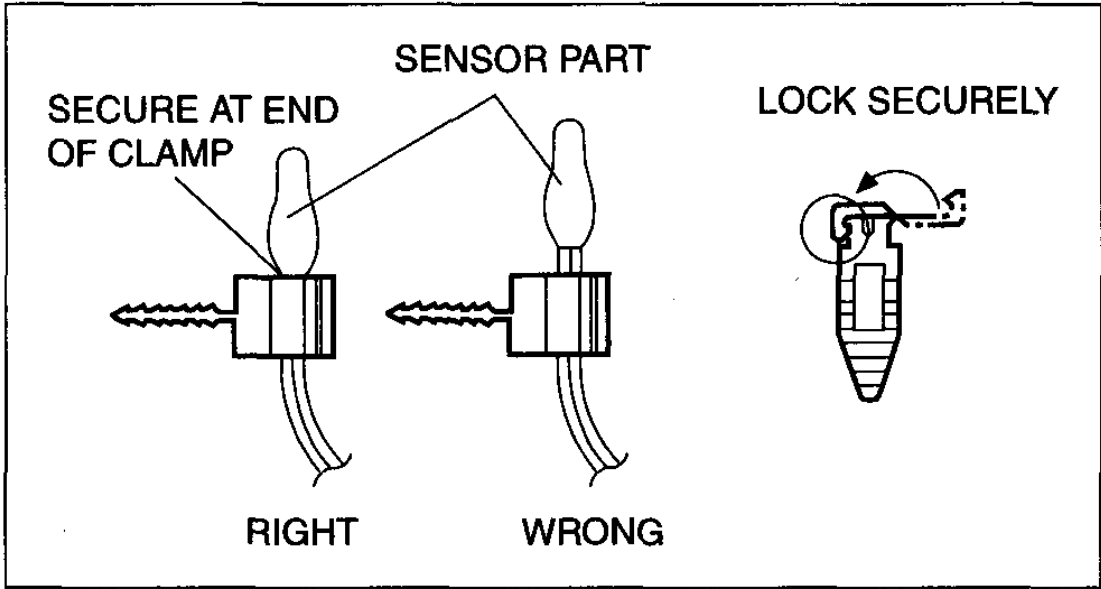

am3zzw0000068

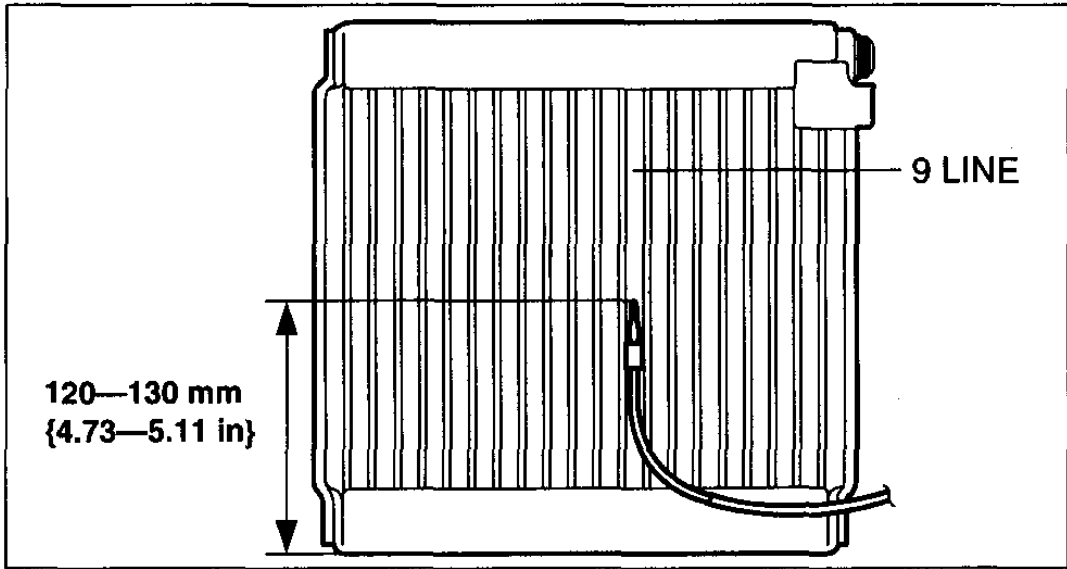

am3zzw0000143

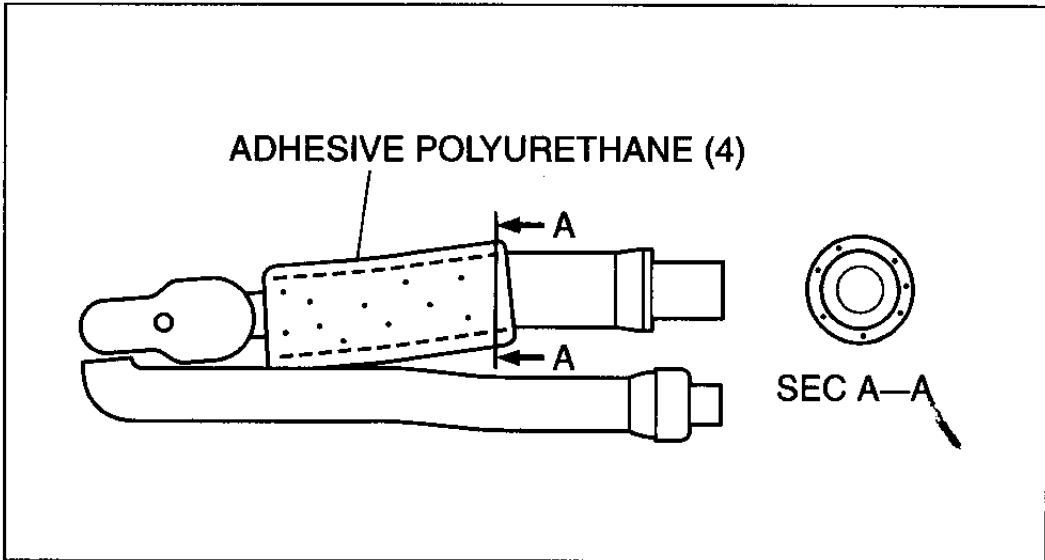

am3uuw0000060

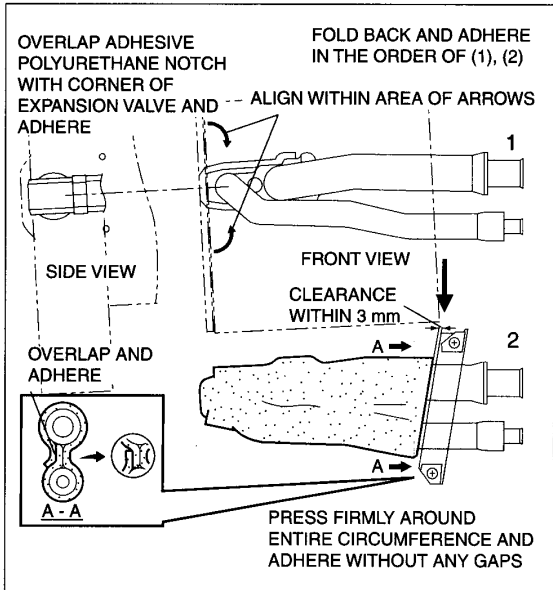

am3uuw0000060

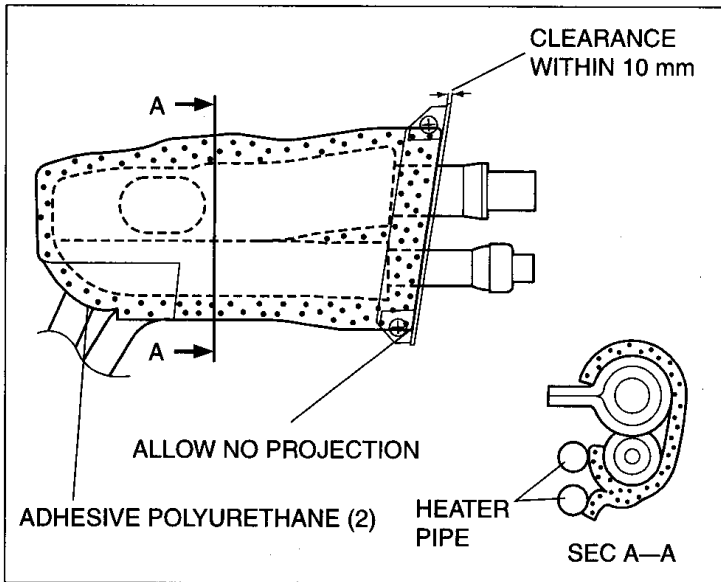

am3uuw000061

A/C Unit Disassembly/Assembly [Manual Air Conditioner] (Article 1393192)

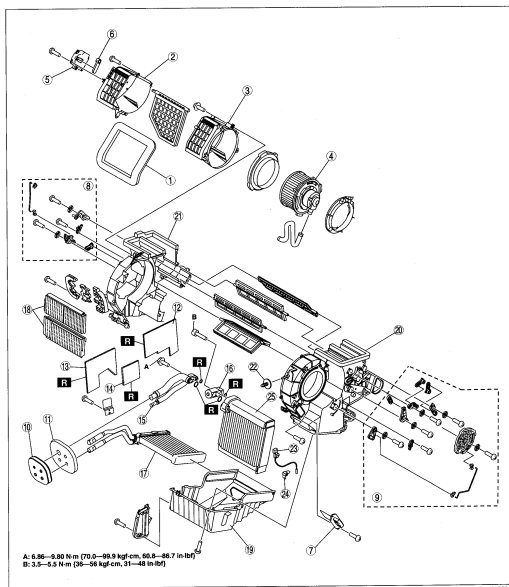

1	Adhesive polyurethane (1)	4	Blower motor
2	Blower case (1)	5	Air intake actuator
3	Blower case (2)	6	Air intake link set

7	Resistor
8	Air mix link set
9	Airflow mode link set
10	Polyurethane foam (1)
11	Polyurethane foam (2)
12	Adhesive polyurethane (2)
13	Adhesive polyurethane (3)
14	Adhesive polyurethane (4)

15	Evaporator pipe
16	Expansion valve
17	Heater core
18	Air filter (vehicle with air filter)
19	A/C case (3)
20	A/C case (1)
21	A/C case (2)
22	Bolt
23	Evaporator temperature sensor
24	Sensor clamp
25	Evaporator

Removal and Replacement (itype_401)

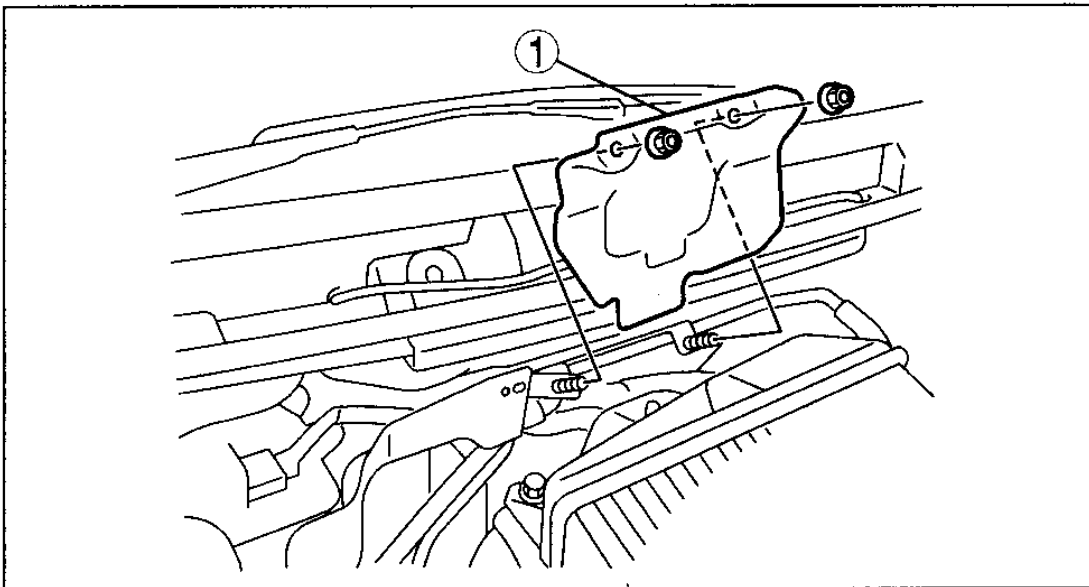

am3uuw0000060

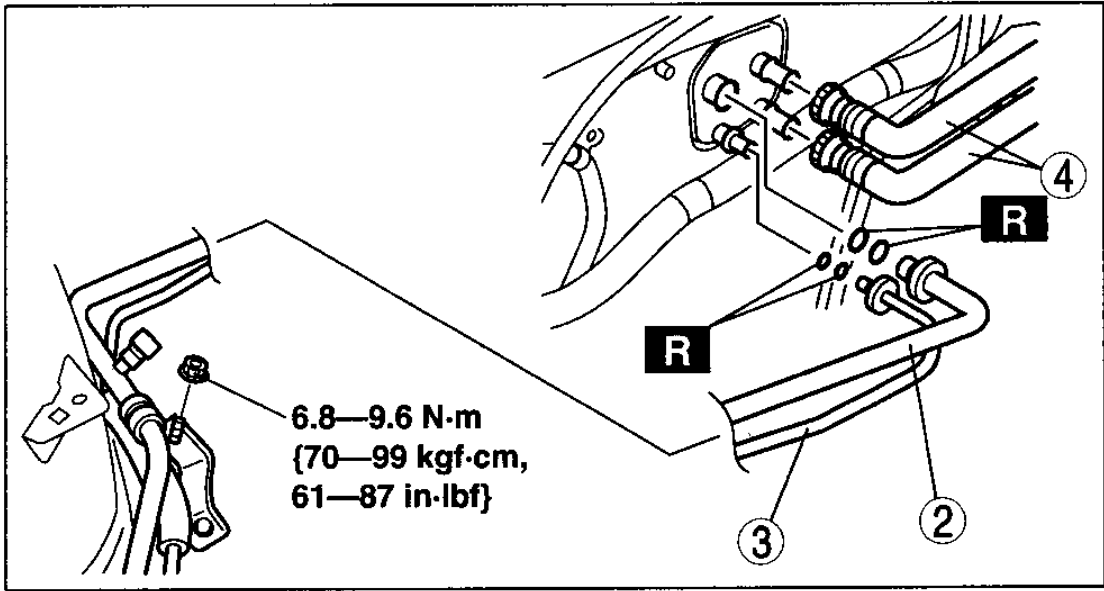

am3uuw0000060

1	Insulator (L3 with TC)
2	Cooler hose (LO)
3	Cooler pipe
4	Heater hose

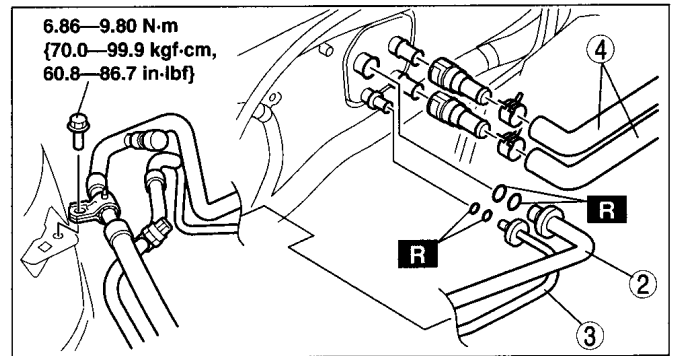

am3uuw0000060

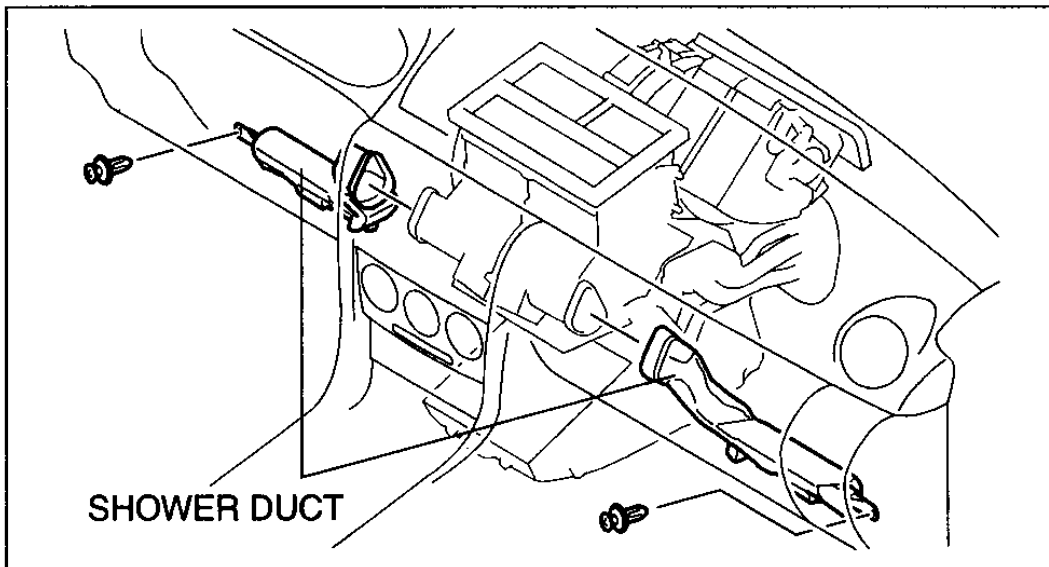

am3zzw0000071

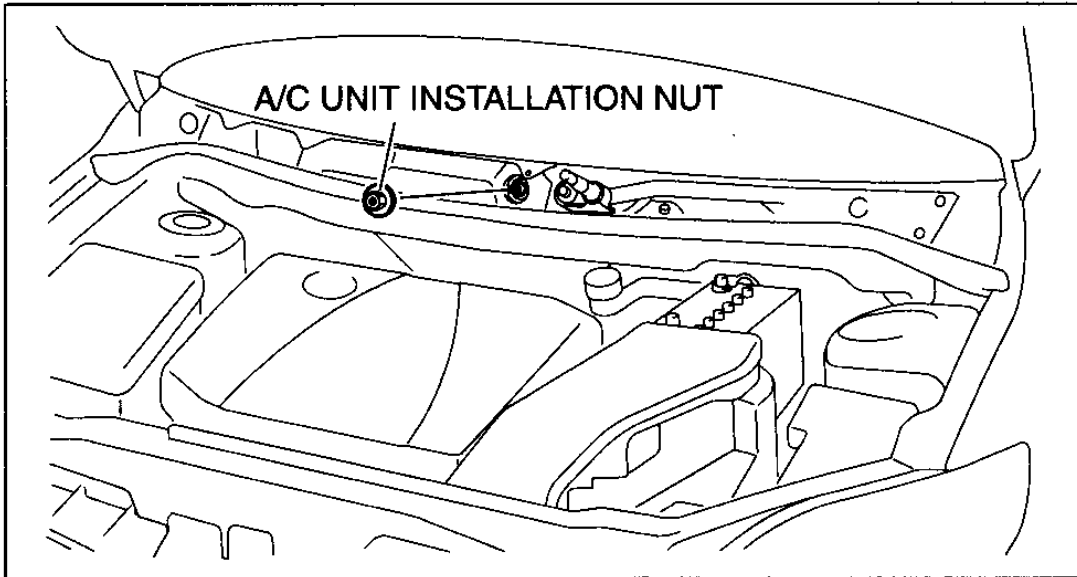

am3zzw0000071

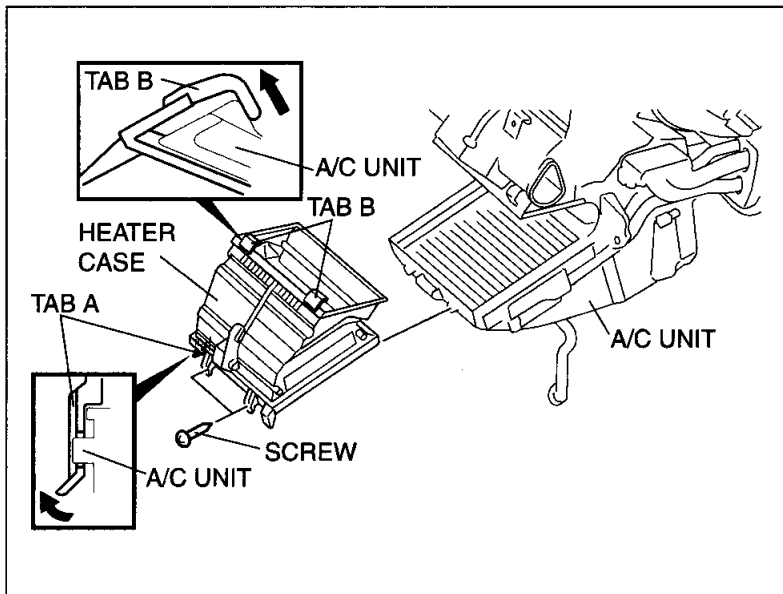

am3zzw0000071

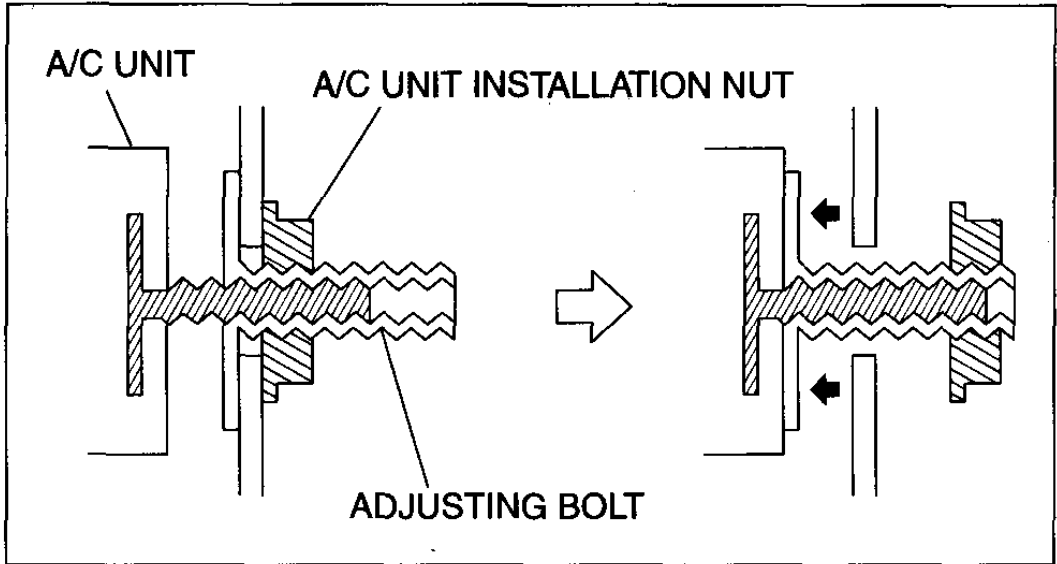

am3zzw0000071

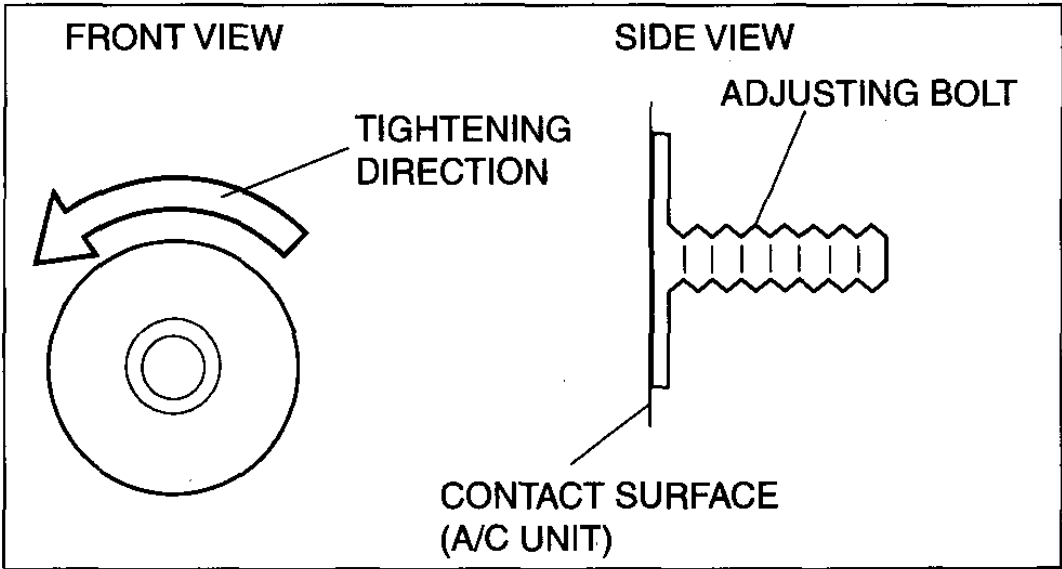

am3zzw0000071

