

# **Component Procedures: Tire Pressure Sensor**

## **Table of Contents**

1. Parts and Labor (itype\_189)
2. Wheel Unit Removal/Installation (Article 1417042)
3. All Technical Service Bulletins (itype\_100)
4. Customer Interest Bulletins (itype\_109)
5. Wheel Unit ID Registration (Article 1422143)

# Component Procedures: Tire Pressure Sensor

## Parts and Labor (itype\_189)

### Parts

| Qualifier            | Part #     | Name   | Price | Note |
|----------------------|------------|--------|-------|------|
| Tire Pressure Sensor | GN3A37140B | Sensor | 84.04 |      |

### Labor

| Operation | Qualifier Path | Skill | Std Hrs | Wty Hrs |
|-----------|----------------|-------|---------|---------|
| Replace   | One            | B     | 0.6     | 0.0     |

## Wheel Unit Removal/Installation (Article 1417042)

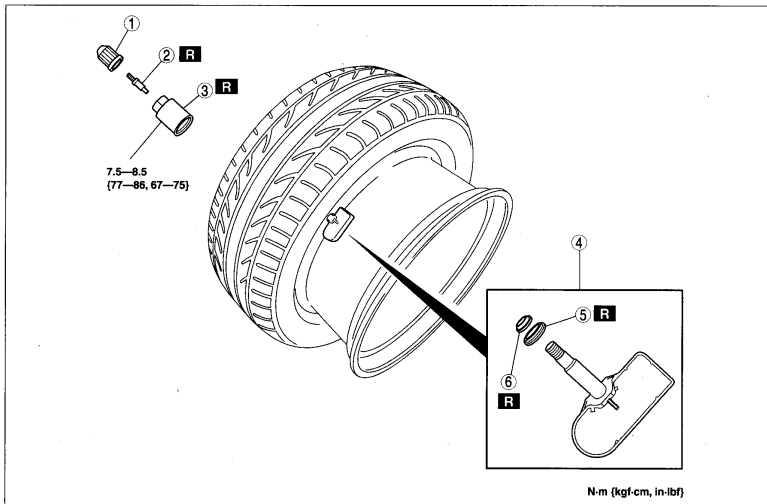

|   |  |
|---|--|
| 1 | Valve cap                                    |
| 2 | Valve core<br>(See Valve Core Removal Note.) |
| 3 | Valve nut and washer                         |

|   |   |
|---|---|
| 4 | Wheel unit<br>(See Wheel Unit Removal Note.)<br>(See Wheel Unit Installation Note.) |
| 5 | Seal washer   |
| 6 | Seal  |

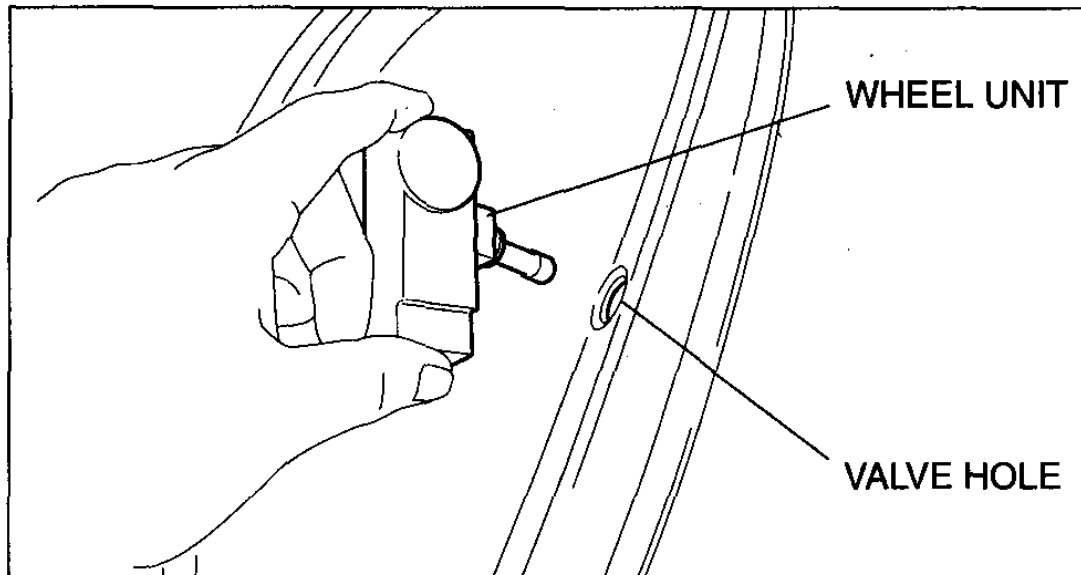

acxuuw00001041

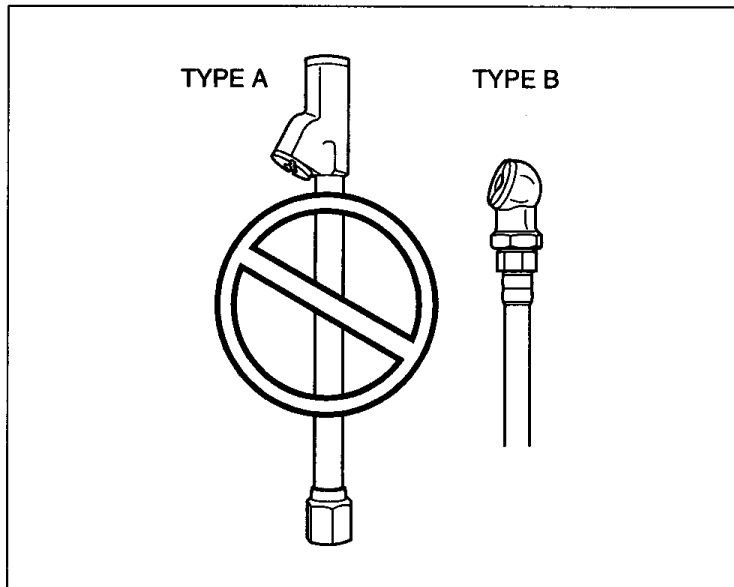
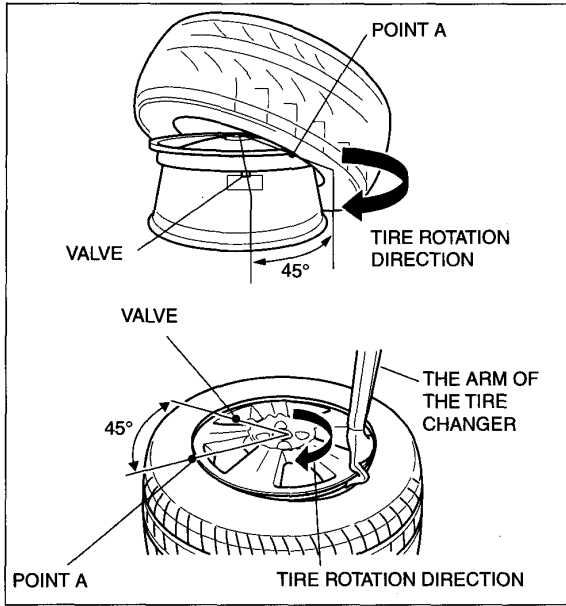

### All Technical Service Bulletins (itype\_100)

Tsbs

- Tire Monitor System - Warning Lamp ON/Low Tire Pressure (0200112, 2012/01/11)

### Customer Interest Bulletins (itype\_109)

Tsbs

- Tire Monitor System - Warning Lamp ON/Low Tire Pressure (0200112, 2012/01/11)

### Wheel Unit ID Registration (Article 1422143)

|                           | WU 1       | WU 2       | WU 3       | WU 4       |
|---------------------------|------------|------------|------------|------------|
| ID Number (Stored)        | 0xAAAAAAAA | 0xBBBBBBBB | 0xCccccccc | 0xDDDDDDDD |
| ID Number (Candidate)     | 0x00000000 | 0x00000000 | 0x00000000 | 0x00000000 |
| Tire Pressure (Stored)    | aaaKPa     | bbbKPa     | cccKPa     | dddKPa     |
| Tire pressure (Candidate) | 0KPa       | 0KPa       | 0KPa       | 0KPa       |

am5uuw0000043