

Component Procedures: Power Steering Fluid

Table of Contents

1. Fluid Types (itype_31)
2. Fluid Types and Capacities (itype_436)
3. All Technical Service Bulletins (itype_100)
4. Customer Interest Bulletins (itype_109)
5. Power Steering Fluid Inspection (Article 1391700)
6. Difficult steering (itype_130)

Component Procedures: Power Steering Fluid

Fluid Types (itype_31)

ATF

M-III or Equivalent (e.g. Dexron II)

Fluid Types and Capacities (itype_436)

Fluid Types

All Technical Service Bulletins (itype_100)

Tsbs

- Power Steering - High Steering Effort/MIL/DTC C1099 (0600110, 2010/04/09)

Customer Interest Bulletins (itype_109)

Tsbs

- Power Steering - High Steering Effort/MIL/DTC C1099 (0600110, 2010/04/09)

Power Steering Fluid Inspection (Article 1391700)

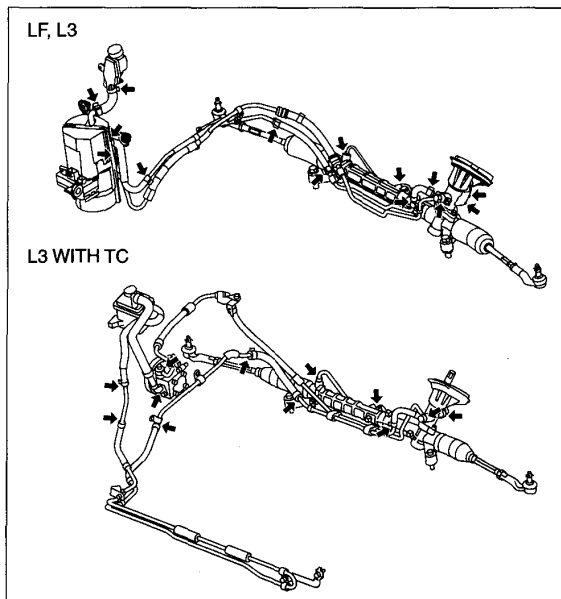

epu614zw3002

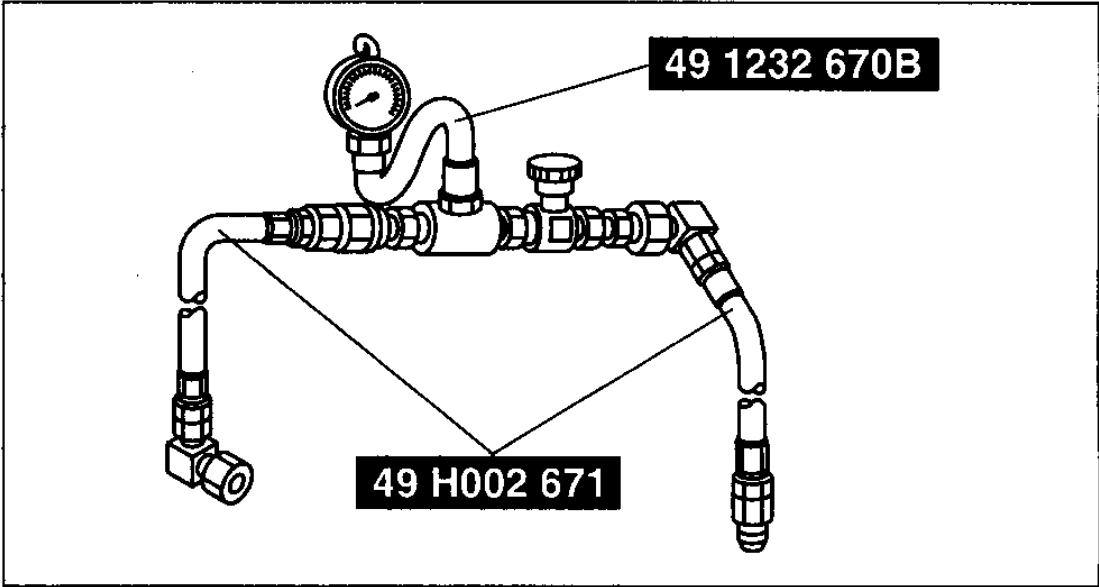

am3uuw000005

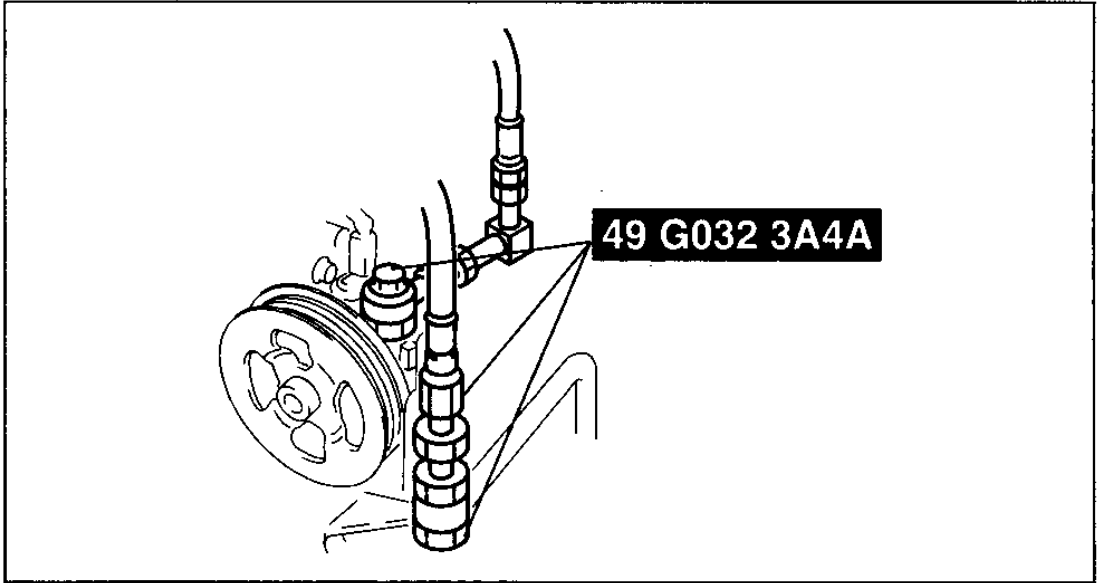

am3uuw000005

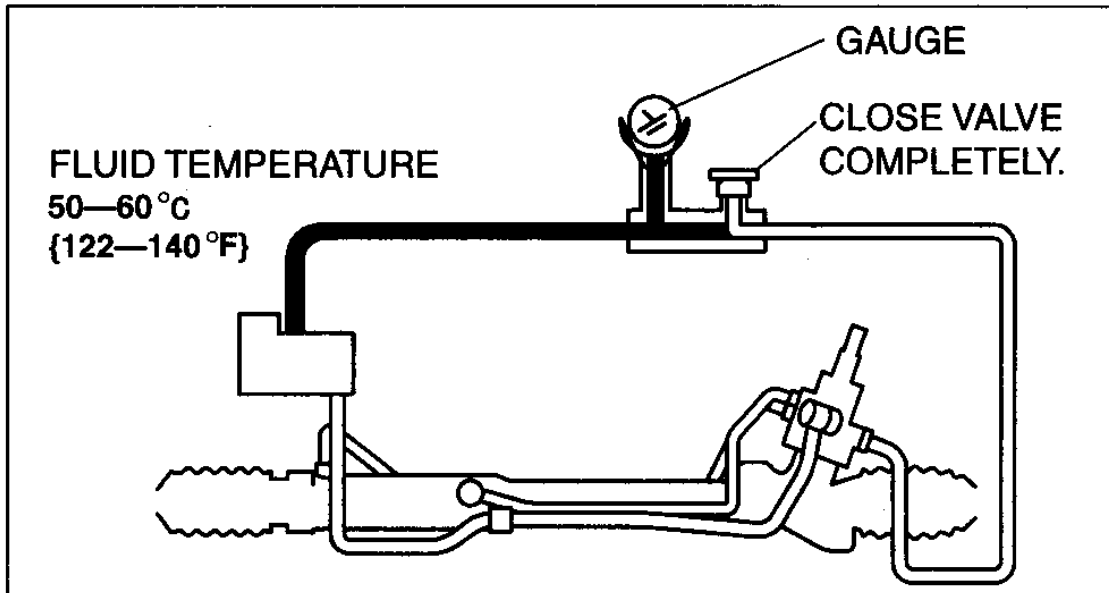

am3uuw0000005

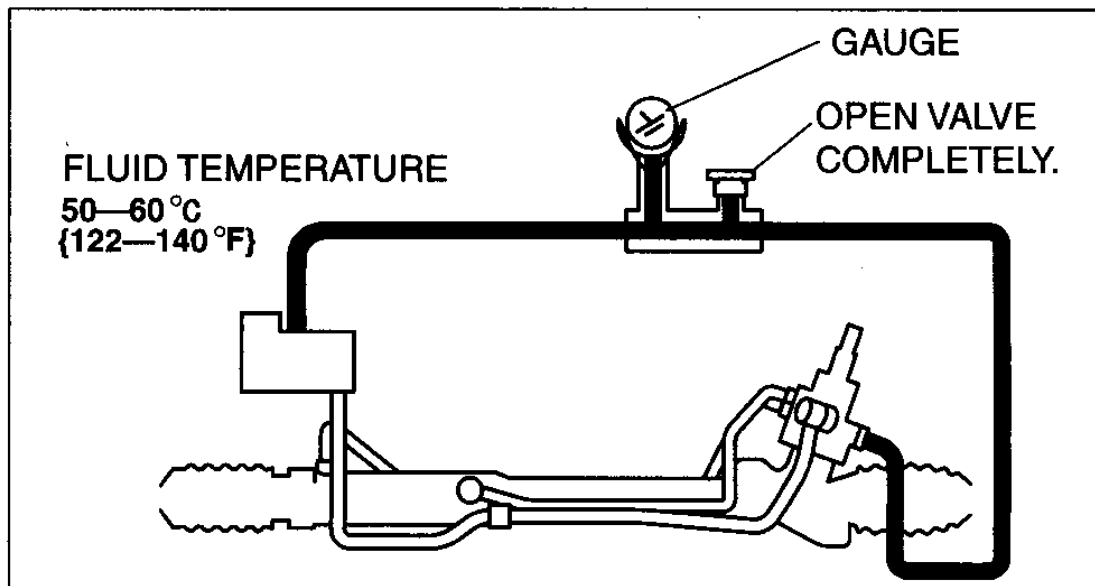

am3uuw0000005

Difficult steering (itype_130)

Tsbs

- Power Steering - High Steering Effort/MIL/DTC C1099 (0600110, 2010/04/09)