

# Component Procedures: Alternator

## Table of Contents

1. Parts and Labor (itype\_189)
2. Electrical (OE) (itype\_21)
3. Overhaul (itype\_402)
4. Removal and Replacement (itype\_401)
5. Electrical (itype\_27)
6. Component Tests and General Diagnostics (itype\_383)

# Component Procedures: Alternator

## Parts and Labor (itype\_189)

### Parts

Qualifier	Part #	Name	Price	Note
Alternator	LF1F18300	1 - Alternator	330.00	

### Labor

Operation	Qualifier Path	Skill	Std Hrs	Wty Hrs
Replace	Alternator, R&R	B	1.2	0.6

## Electrical (OE) (itype\_21)

For information regarding diagrams for this component, please refer to

Charging System

Diagrams.

See: Charging System > Electrical

## Overhaul (itype\_402)

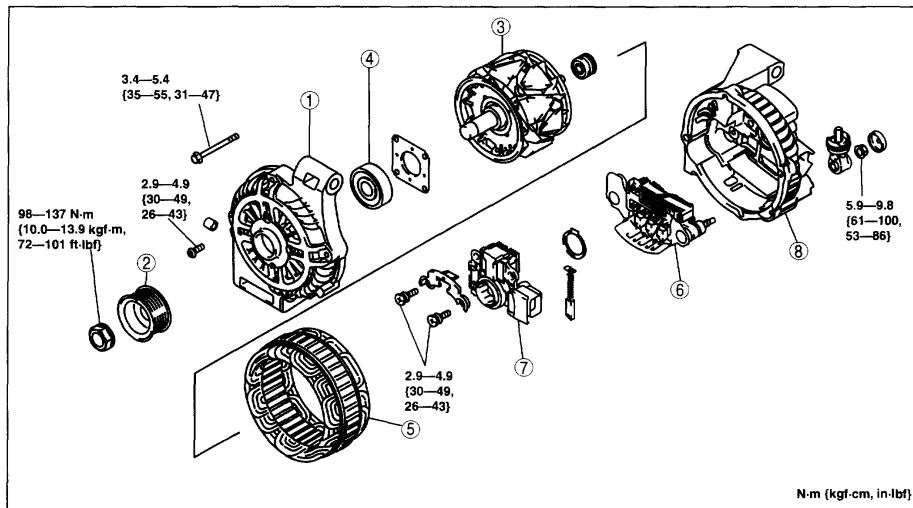

1	Front cover
2	Pulley
3	Rotor
4	Bearing

5	Stator coil
6	Rectifier
7	Brush holder
8	Rear bracket

## Removal and Replacement (itype\_401)

1	Terminal B cable
2	Generator connector
3	Generator

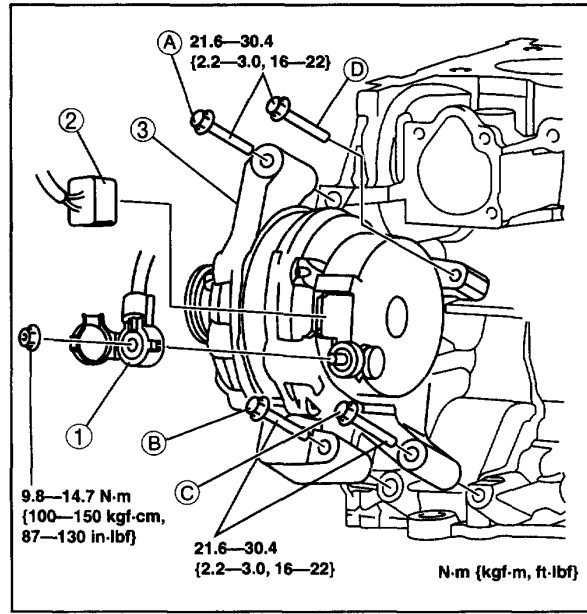

Electrical (itype\_27)

## Standard specification

Terminal	IG-ON (V)	Idle (V) [20°C {68 °F}]
B	B+	13.0—15.0
P	Approx. 1.0 or less	Approx. 3.0—8.0
D	Approx. 0	*

\* : Turn the following electrical loads on and verify that the voltage reading increases.

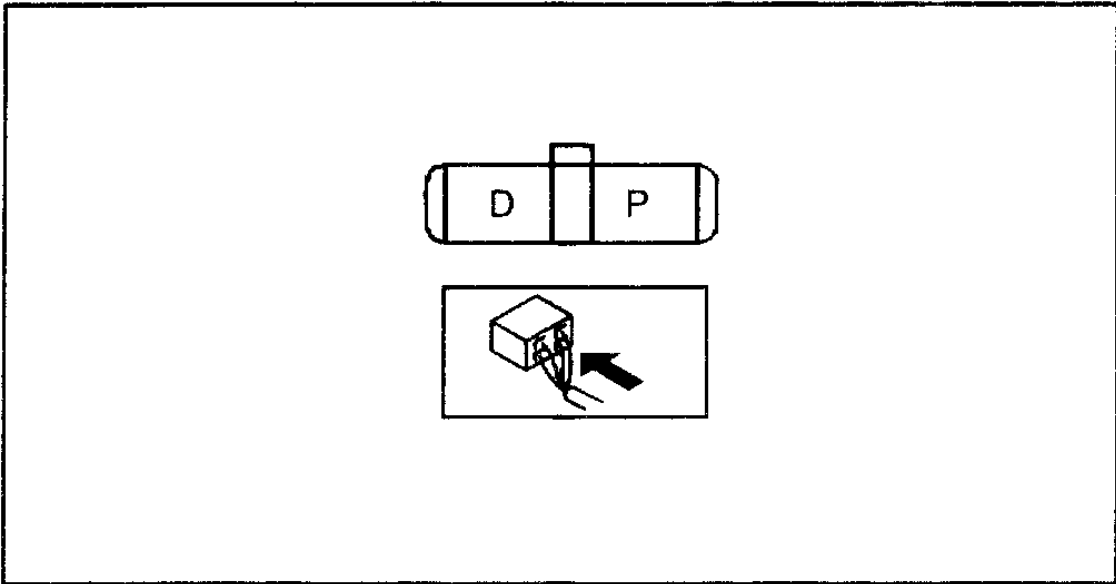

am3uuw000095

Component Tests and General Diagnostics (itype\_383)

**Standard specification**

Terminal	IG-ON (V)	Idle (V) [20°C {68 °F}]
B	B+	13.0—15.0
P	Approx. 1.0 or less	Approx. 3.0—8.0
D	Approx. 0	*

\* : Turn the following electrical loads on and verify that the voltage reading increases.

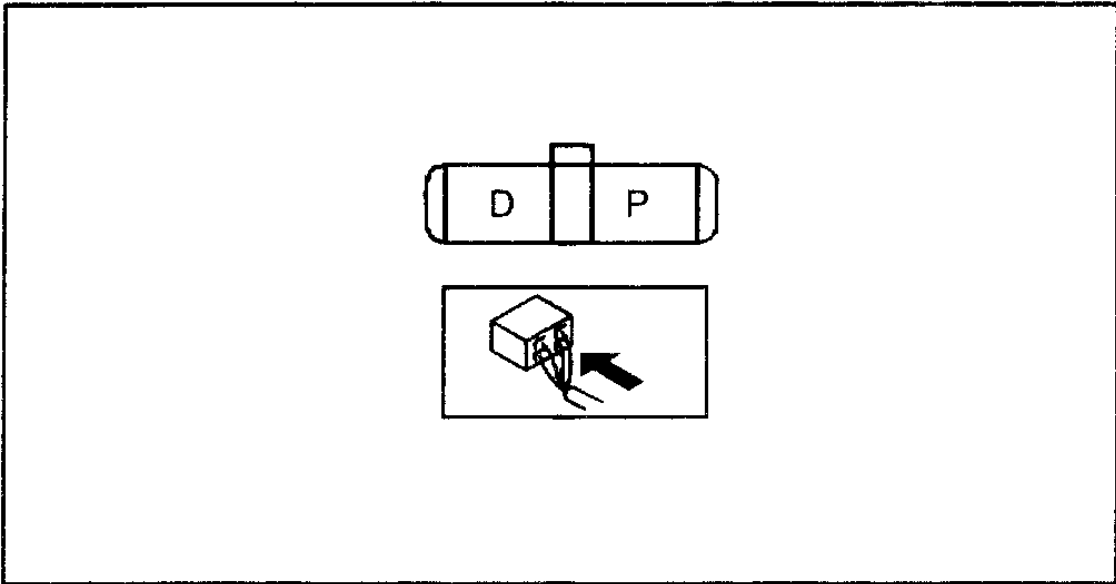

am3uuw000095

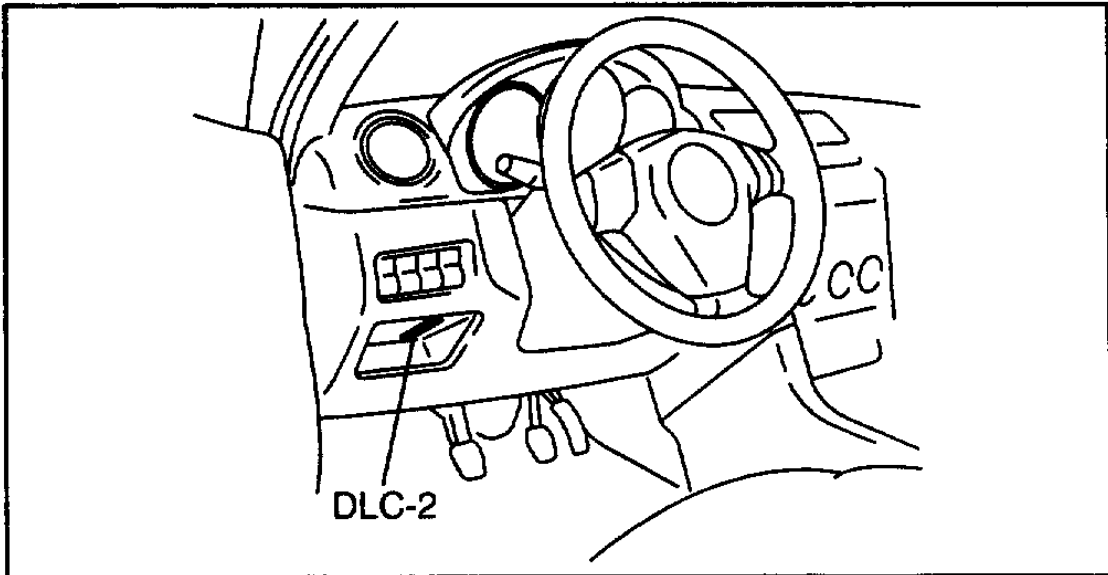

am3uuw000095

Step	Inspection		Action
1	Measure the generator terminal B voltage when the electrical loads <sup>11</sup> are on and off.	15 V or more 13-15 V 13 V or less	Go to Step 2. Normal <sup>2</sup> Go to Step 3.
2	Monitor the ALTT V PID using the M-MDS, or measure the voltage of PCM terminal 2AJ <sup>3</sup> , 2AM <sup>4</sup> , 2AJ <sup>5</sup> using a tester. Is the voltage between 13-15 V ?	Yes No	Go to Step 4. PCM input error.
3	Monitor the ALTT V PID using the M-MDS, or measure the voltage of PCM terminal 2AJ <sup>3</sup> , 2AM <sup>4</sup> , 2AJ <sup>5</sup> using a tester. Is the voltage between 13-15 V ?	Yes No	Go to Step 5. PCM input error.
4	Monitor the ALTF PID using the M-MDS, or calculate the duty value of the PCM terminal 2AI <sup>3</sup> , 2AQ <sup>4</sup> , 2AI <sup>5</sup> using an oscilloscope. Is the duty value 100 % ?	Yes No	PCM input error. PCM, generator, or both is not normal.
5	Monitor the ALTF PID using the M-MDS, or calculate the duty value of the PCM terminal 2AI <sup>3</sup> , 2AQ <sup>4</sup> , 2AI <sup>5</sup> using an oscilloscope. Is the duty value 0 % ?	Yes No	PCM input error. PCM, generator, or both is not normal.

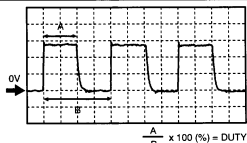
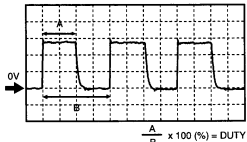

- <sup>11</sup> : Headlights, blower motor, rear window defroster, and brake lights.  
<sup>2</sup> : If the generator field coil duty value does not change when electrical loads (such as headlights, blower motor, rear window defroster, brake lights) are on or off, inspection with discharged battery is needed.  
<sup>3</sup> : California emission regulation applicable model  
<sup>4</sup> : Except for California emission regulation applicable model with LF ATX  
<sup>5</sup> : Except for California emission regulation applicable model with LF MTX, L3

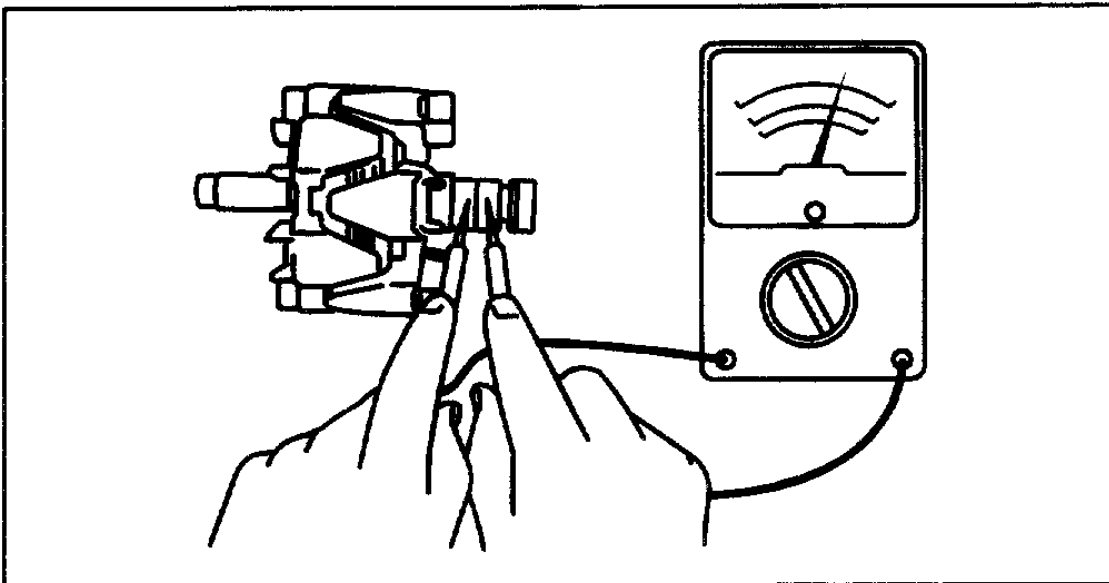

am3uuw000095

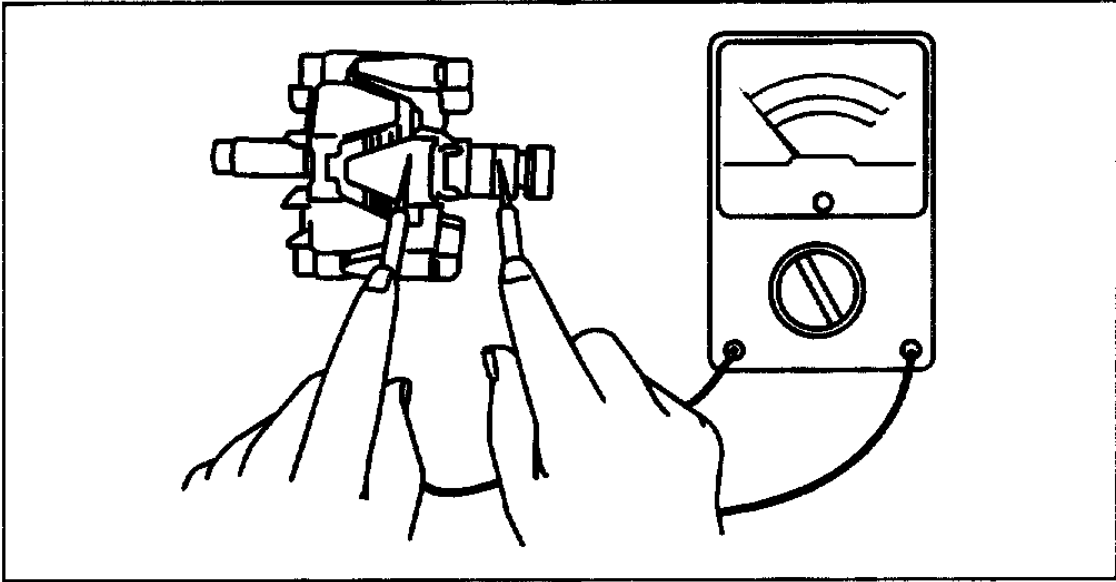

am3uuw000095

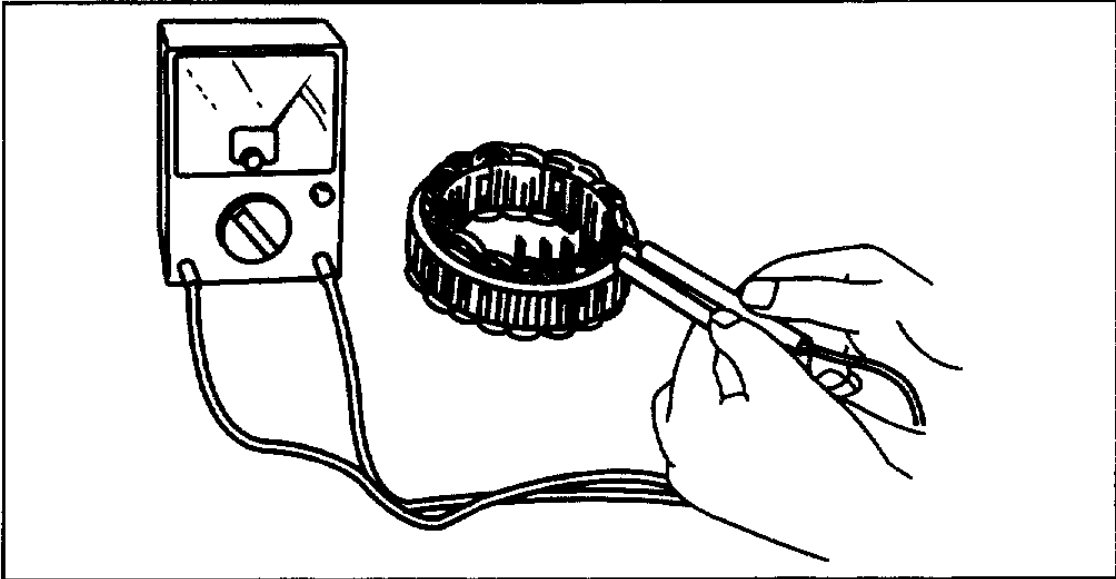

am3uuw000095

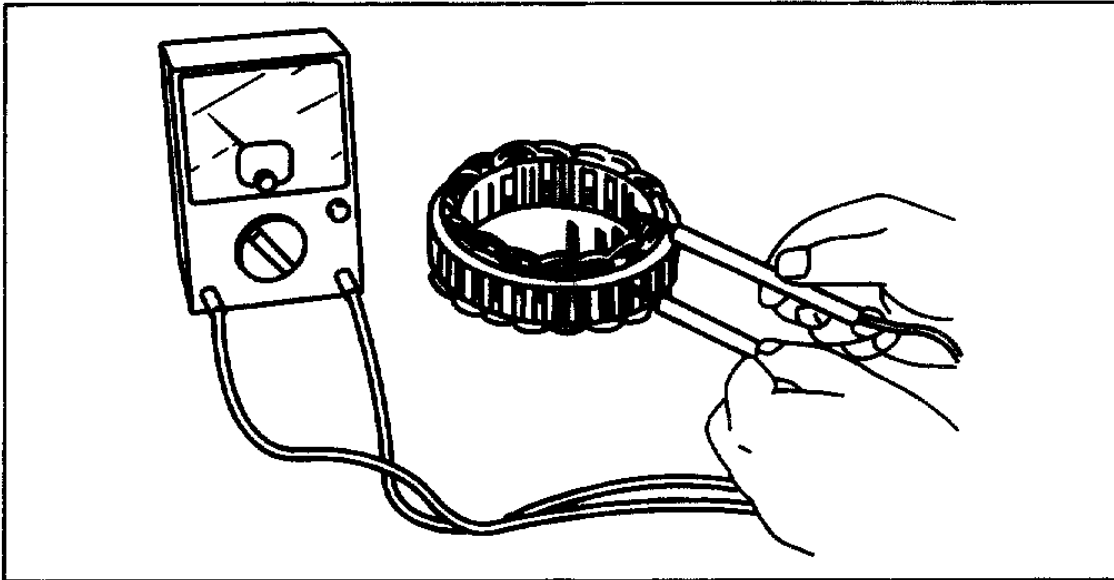

am3uuw000095

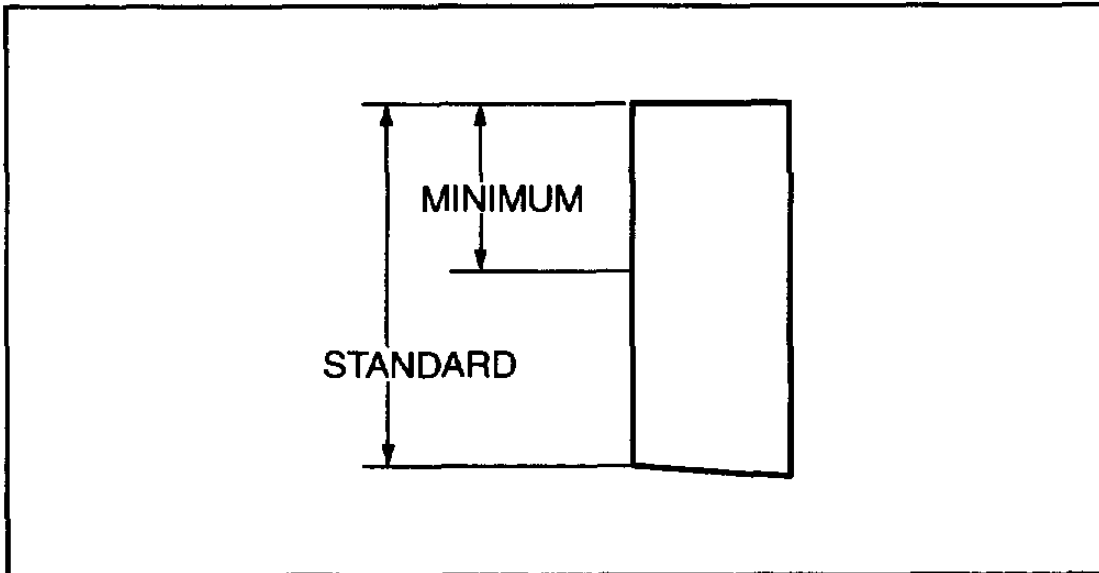

am3uuw000096

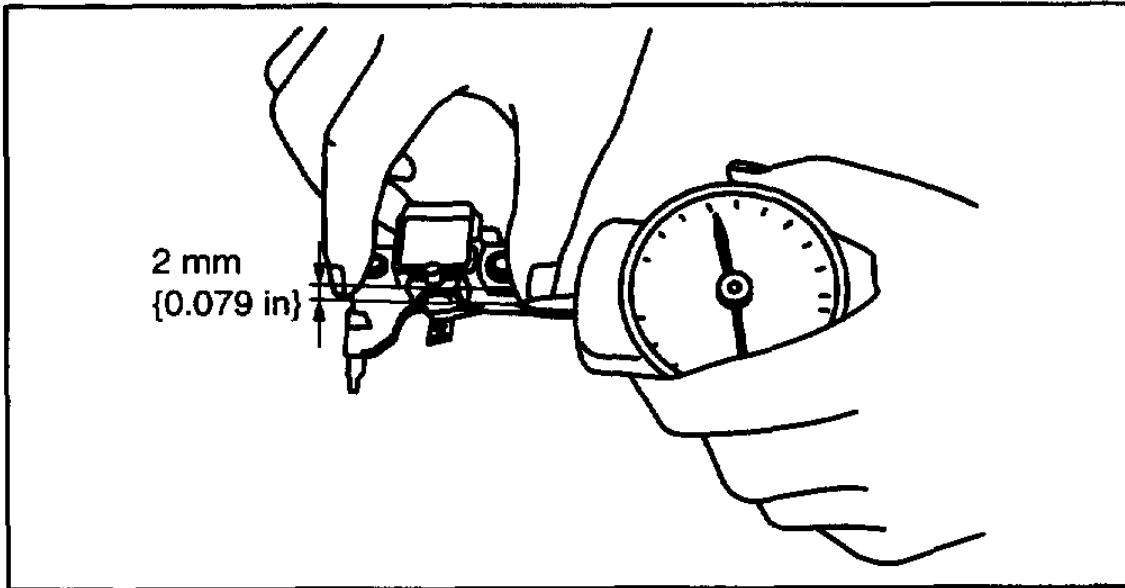

am3uuw0000096

## Specification

Tester		Continuity
Negative	Positive	
E	P1, P2, P3, P4	Yes
B		No
P1, P2, P3, P4	E	No
	B	Yes

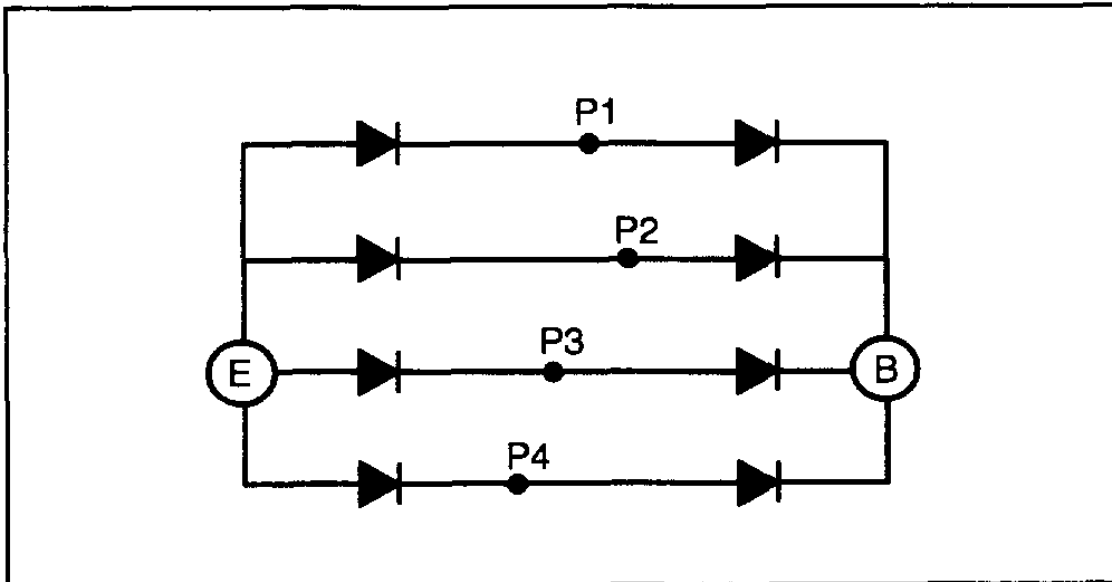

chu0117w011

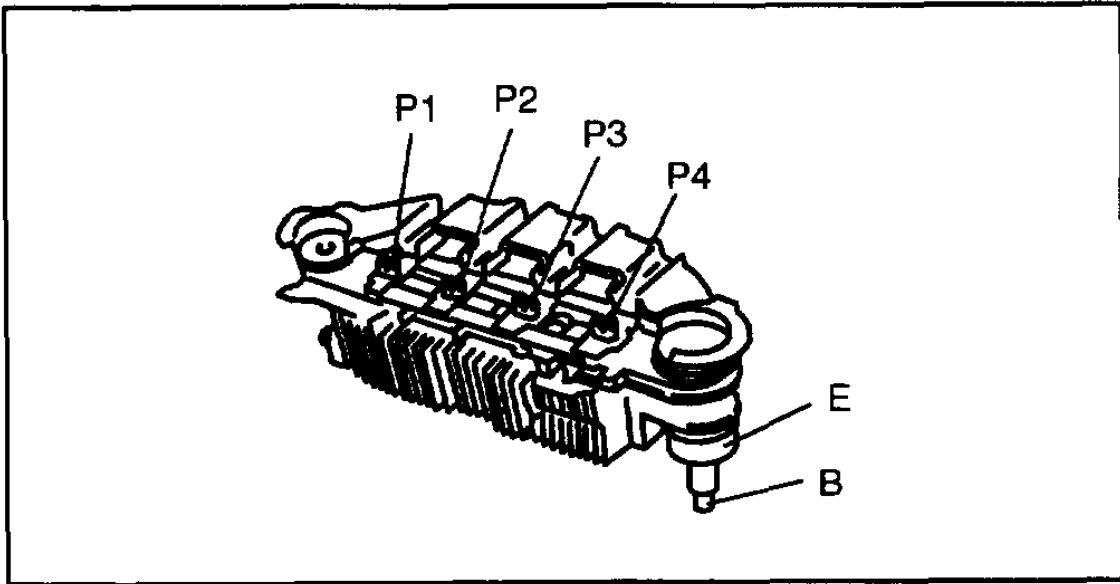

chu0117w013

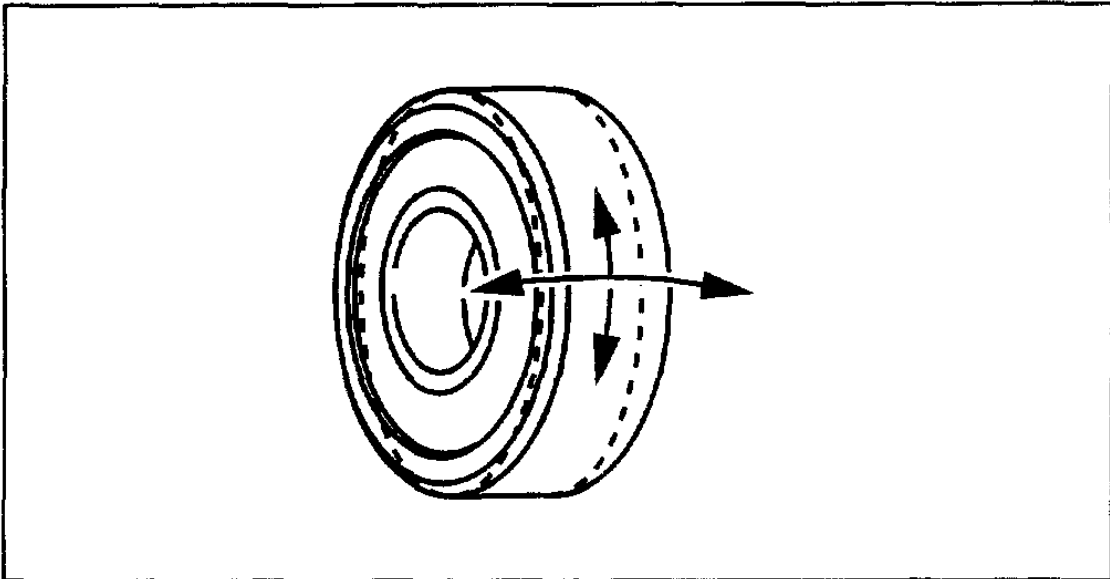

am3uuw000096