

Component Procedures: Engine Oil Pressure

Table of Contents

1. Pressure, Vacuum and Temperature (itype_29)
2. Oil Pressure Inspection (Article 1388054)

Component Procedures: Engine Oil Pressure

Pressure, Vacuum and Temperature (itype_29)

Oil Pressure

Oil pressure (reference value) [oil temperature: 100° C (212° F)] 337 - 591 kPa (3.44 - 6.03 kgf/cm², 49.0 - 85.8 psi) [3,000 rpm]

Oil Pressure Inspection (Article 1388054)

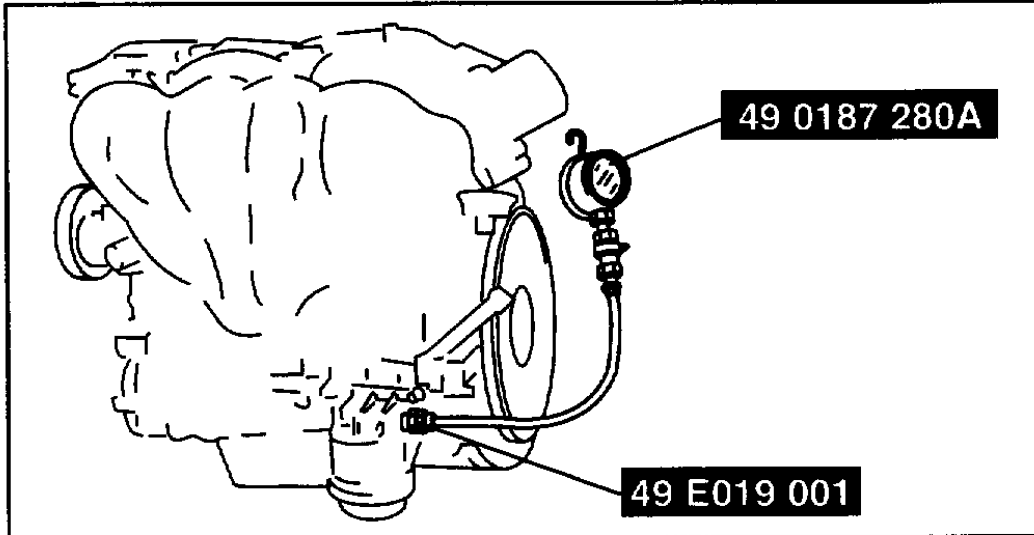

D6E111AW3004

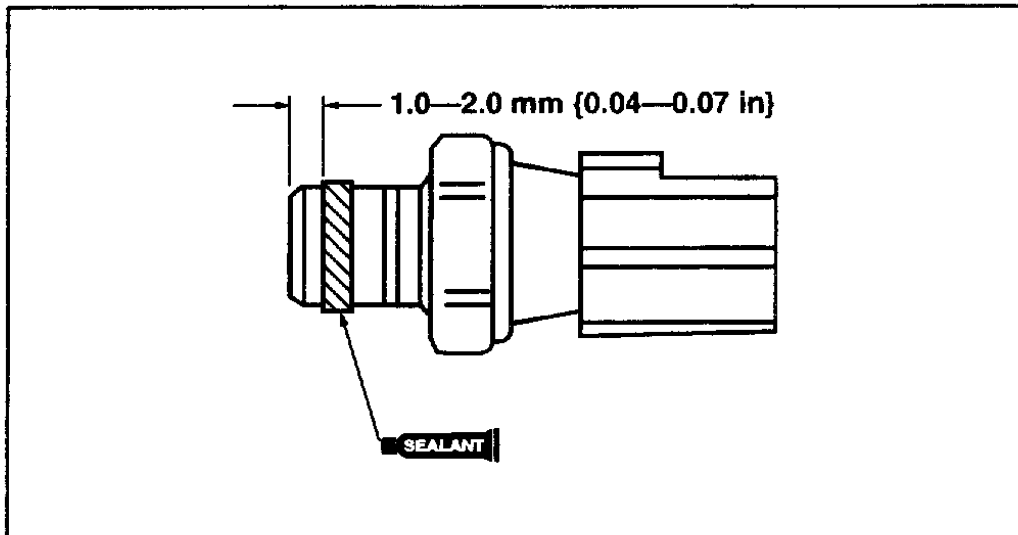

B3E0111W003