

Component Procedures: Tire Monitoring System

Table of Contents

1. Tire Pressure Adjustment (With TPMS) (Article 1421050)
2. Diagrams and Routing Views (Article 1420815)
3. System Schematic (Article 1420813)
4. Tire Pressure Monitoring Circuit (Article 16503)
5. TPMS Reset After Tire Rotation or Flat Repair (Article 1422299)
6. All Technical Service Bulletins (itype_100)
7. Customer Interest Bulletins (itype_109)
8. Repair Tips (itype_110)
9. On-Board Diagnostic (OBD) Test Description (Article 1422259)
10. Malfunctioning Wheel Unit Identification (Article 1409817)
11. Foreword (Article 1422260)
12. Precaution (Article 1422261)
13. TPMS Reset After Tire Rotation or Flat Repair (Article 1422103)
14. Wheel Unit ID Registration (Article 1422104)
15. Reading Diagnostic Trouble Codes (Article 1422237)
16. Clearing Diagnostic Trouble Codes (Article 1422239)
17. PID/Data Monitor and Record Procedure (Article 1422122)
18. PID/Data Monitor Table (Article 1422123)
19. Active Command Modes Procedure (Article 1422124)
20. Freeze Frame PID Data Access Procedure (Article 1422126)
21. Active Command Modes Table (Article 1422125)
22. Symptom Troubleshooting (Article 1422105)
23. No.1 TPMS Warning Light Illuminates Continuously (Article 1422177)
24. No.2 TPMS Warning Light (Low Pressure Warning) Illuminates After Engine Start and Turns Off After Driving For Period of Time (Article 1422195)
25. No.3 Wheel Unit ID Registration Cannot Be Performed (TPMs Warning Light Flashes) (Article 1422197)

Component Procedures: Tire Monitoring System

Tire Pressure Adjustment (With TPMS) (Article 1421050)

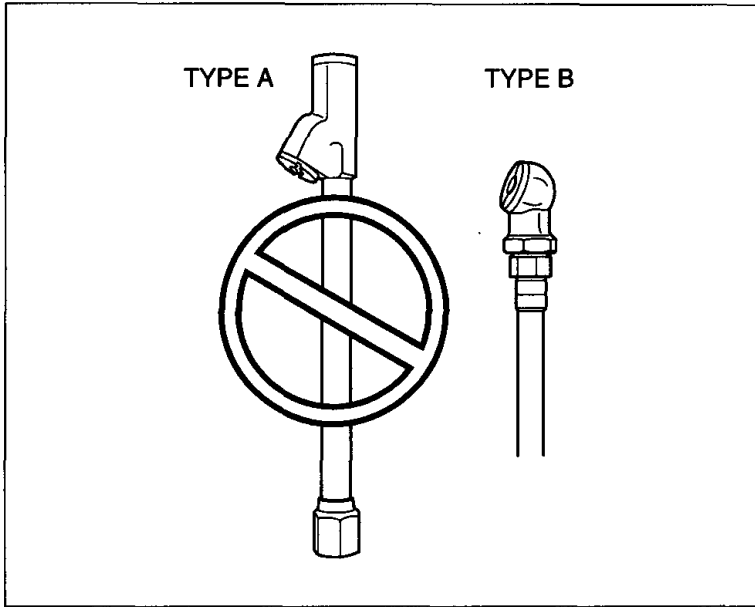

E6U212ZWC001

Diagrams and Routing Views (Article 1420815)

TIRE PRESSURE MONITORING SYSTEM (INCLUDES KEYLESS ENTRY SYSTEM INFORMATION)

0212

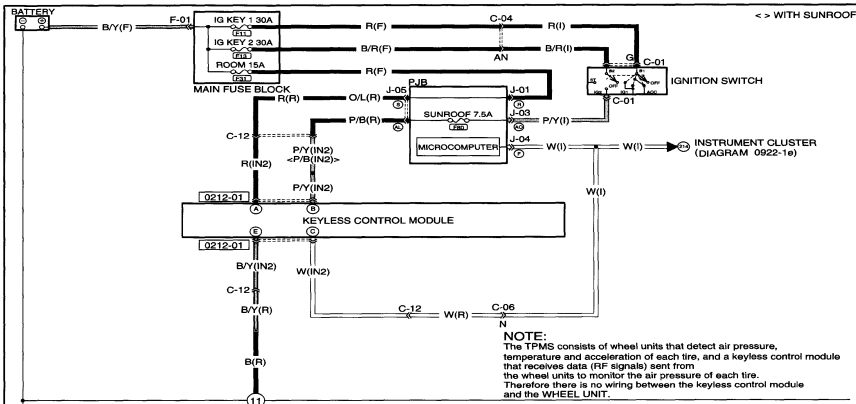

777						
0212-01 KEYLESS CONTROL MODULE						

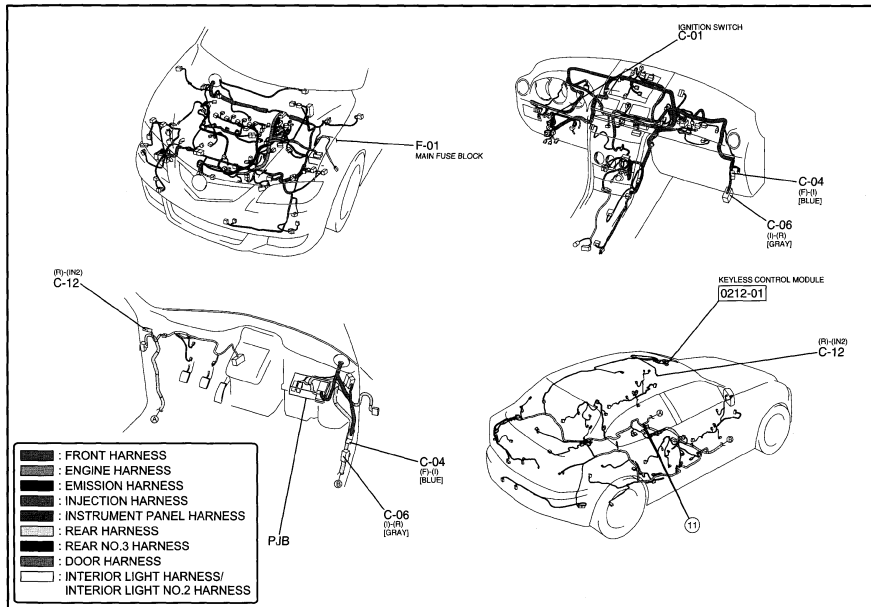

System Schematic (Article 1420813)

Non Standards

- Tire Pressure Monitoring System (TPMS) Wiring Diagram (1420814)

Tire Pressure Monitoring Circuit (Article 16503)

Warning Systems - Tire Pressure Monitoring Circuit

Page 1 of 1

TPMS Reset After Tire Rotation or Flat Repair (Article 1422299)

The TPMS system will turn the warning lamp off after the vehicle is driven over 16 mph (25 km/h) for 10 minutes.

The system is not affected by tire rotation

All Technical Service Bulletins (itype_100)

Tsbs

- Tire Monitor System - Warning Lamp ON/Low Tire Pressure (0200112, 2012/01/11)
- Tire Monitor System - Service Precautions (0200410, 2010/03/24)
- Tire Monitor System - Service Precaution (0200311, 2011/06/23)
- Tire Monitor System - Can't Turn OFF/On Reprogram (MTIP-08-05-5, 2008/05/01)

Customer Interest Bulletins (itype_109)

Tsbs

- Tire Monitor System - Warning Lamp ON/Low Tire Pressure (0200112, 2012/01/11)

Repair Tips (itype_110)

Tsbs

- Tire Monitor System - Service Precautions (0200410, 2010/03/24)
- Tire Monitor System - Service Precaution (0200311, 2011/06/23)
- Tire Monitor System - Can't Turn OFF/On Reprogram (MTIP-08-05-5, 2008/05/01)

On-Board Diagnostic (OBD) Test Description (Article 1422259)

TIRE PRESSURE MONITORING SYSTEM (TPMS) WIRING DIAGRAM

id020200800100

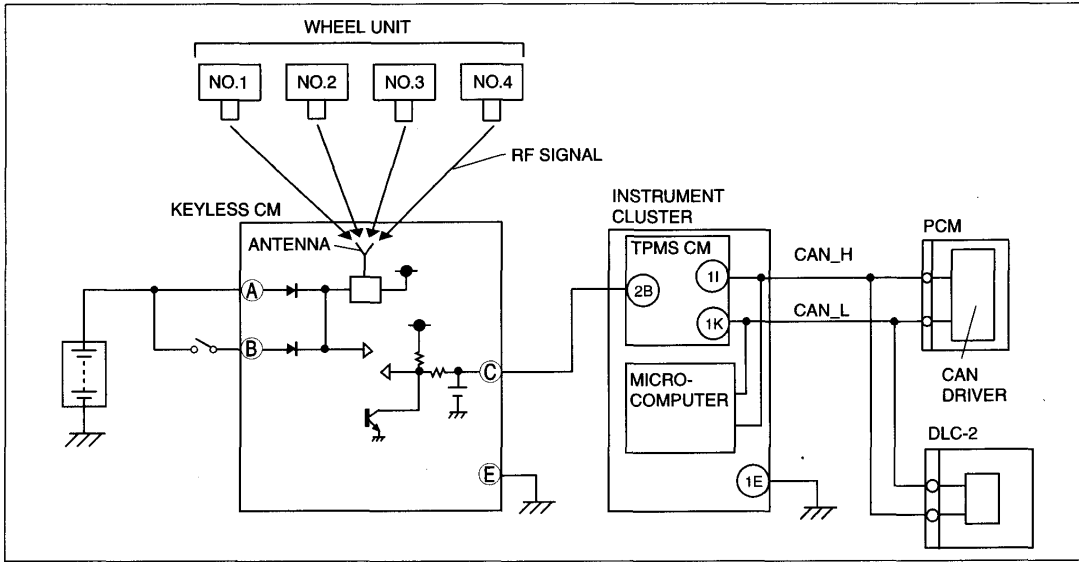

am3uuw000082

Malfunctioning Wheel Unit Identification (Article 1409817)

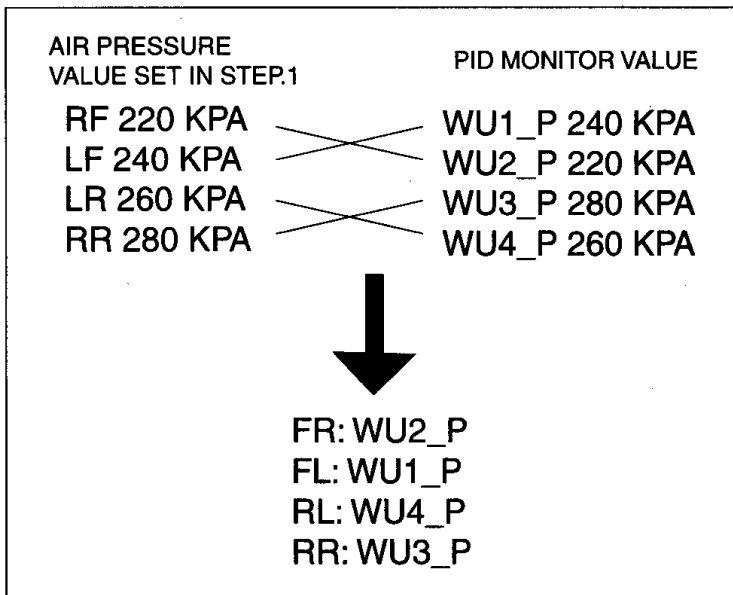

E3U212ZW6001

Foreword (Article 1422260)

FOREWORD

^ Before performing the steps in Symptom Troubleshooting, perform the On-board Diagnostic Inspection. To check the DTC, follow the DTC Inspection steps. (See

TIRE PRESSURE MONITORING SYSTEM (TPMS) ON-BOARD DIAGNOSIS.)

See: Tire Monitoring System > Initial Inspection and Diagnostic Overview > On-Board Diagnostic (OBD) Test Description

Precaution (Article 1422261)

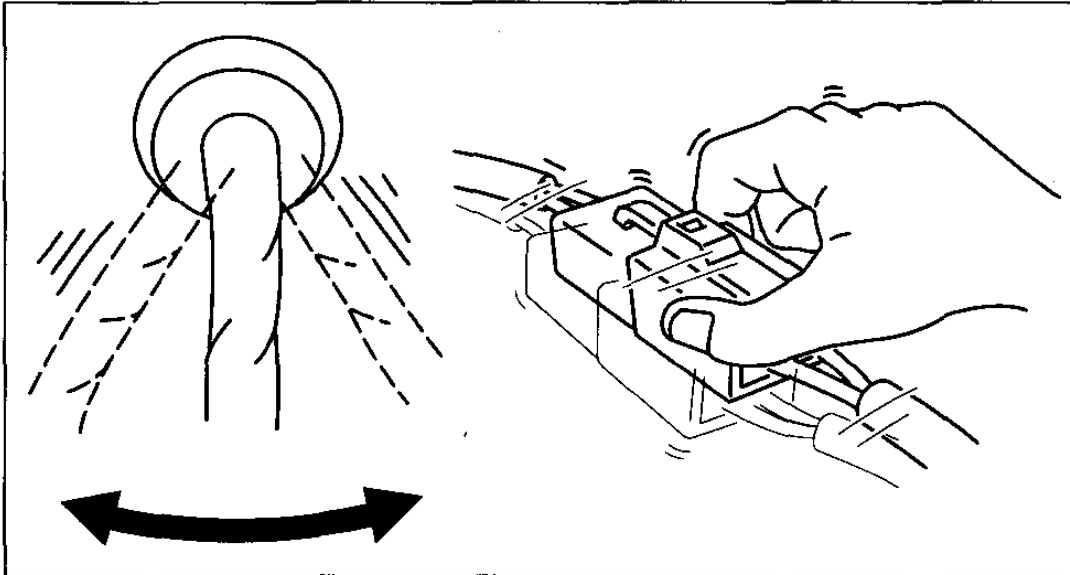

B3E0603W001

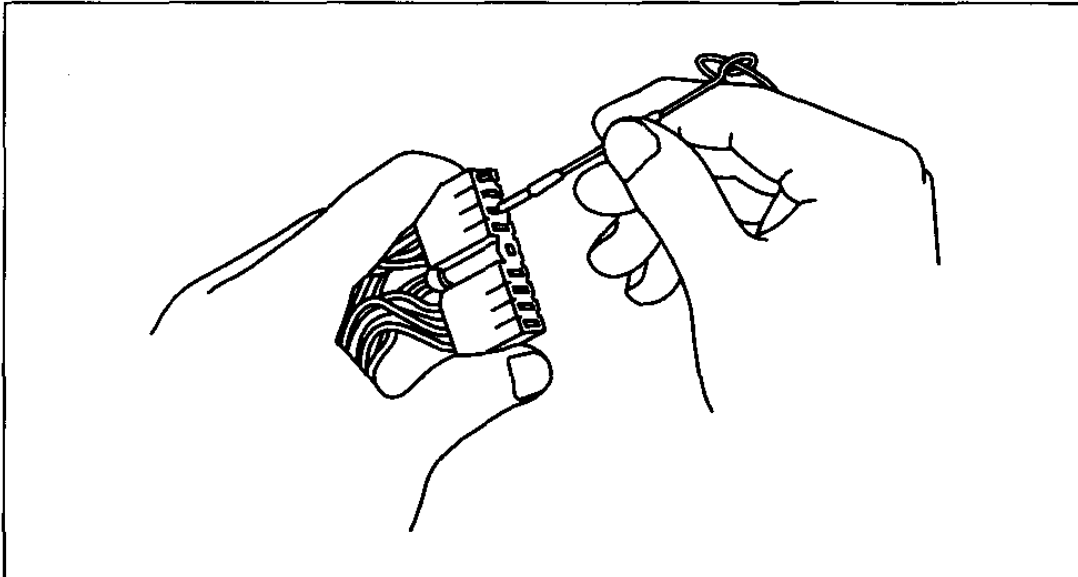

B3E0603W002

TPMS Reset After Tire Rotation or Flat Repair (Article 1422103)

The TPMS system will turn the warning lamp off after the vehicle is driven over 16 mph (25 km/h) for 10 minutes.

The system is not affected by tire rotation

Wheel Unit ID Registration (Article 1422104)

	WU 1	WU 2	WU 3	WU 4
ID Number (Stored)	0xAAAAAAAA	0xBBBBBBBB	0xCccccccc	0xDDDDDDDD
ID Number (Candidate)	0x00000000	0x00000000	0x00000000	0x00000000
Tire Pressure (Stored)	aaaKPa	bbbKPa	cccKPa	dddKPa
Tire pressure (Candidate)	0KPa	0KPa	0KPa	0KPa

am5uuw000043

Reading Diagnostic Trouble Codes (Article 142237)

Non Standards

- With Manufacturer's Scan Tool (142238)

Clearing Diagnostic Trouble Codes (Article 142239)

Non Standards

- With Manufacturer's Scan Tool (142240)

PID/Data Monitor and Record Procedure (Article 1422122)

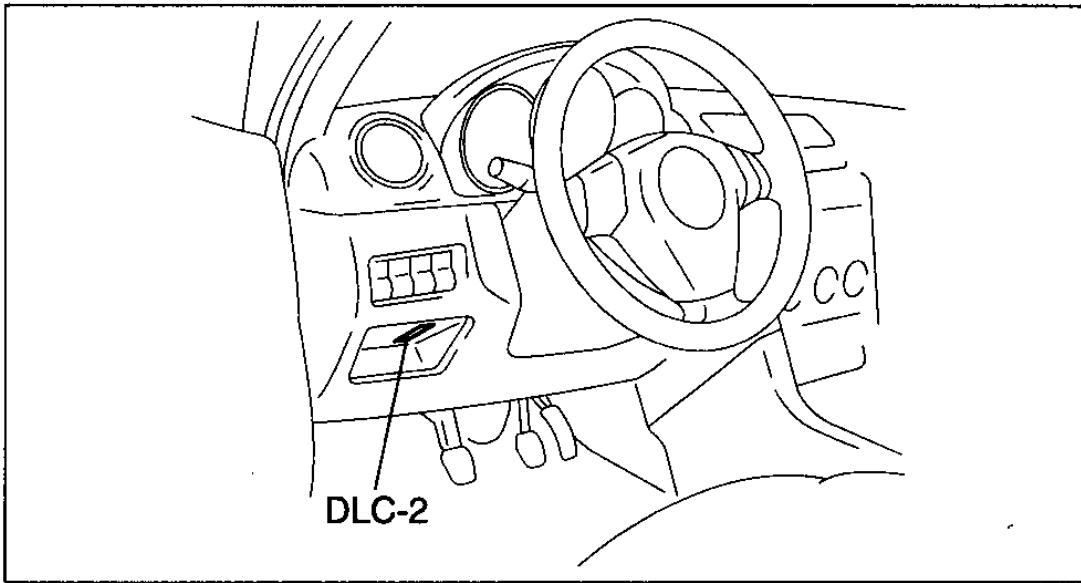

am3zzw0000168

PID/Data Monitor Table (Article 1422123)

PID/DATA Monitor Table

PID Name (Definition)	Unit/Condition	Condition/Specification	Action
AI_WU1_ID AI_WU2_ID AI_WU3_ID AI_WU4_ID (Wheel unit ID code (during ID registration))	-	Indicates the wheel unit ID code. (During wheel unit ID registration.)	<ul style="list-style-type: none"> Replace the wheel unit. Perform the wheel unit ID registration.
AI_WU1_P AI_WU2_P AI_WU3_P AI_WU4_P (Tire pressure value (during ID registration))	Pa, psi	Indicates the tire pressure. (During ID registration.)	<ul style="list-style-type: none"> Adjust tire pressure. Replace the wheel unit. Perform the wheel unit ID registration.
FFD1_WU1_P FFD1_WU2_P FFD1_WU3_P FFD1_WU4_P (Tire pressure value (freeze frame PID data 1))	Pa, psi	Indicates the tire pressure. (Freeze frame PID data 1)	Adjust tire pressure.
FFD2_WU1_P FFD2_WU2_P FFD2_WU3_P FFD2_WU4_P (Tire pressure value (freeze frame PID data 2))	Pa, psi	Indicates the tire pressure. (Freeze frame PID data 2)	Adjust tire pressure.
FFD1_WU1_T FFD1_WU2_T FFD1_WU3_T FFD1_WU4_T (Internal tire air temperature value (freeze frame PID data 1))	°C, °F	Indicates the internal tire air temperature. (Freeze frame PID data 1)	Adjust tire pressure.

PID Name (Definition)	Unit/Condition	Condition/Specification	Action
FFD2_WU1_T FFD2_WU2_T FFD2_WU3_T FFD2_WU4_T (Internal tire air temperature value (freeze frame PID data 2))	°C, °F	Indicates the internal tire air temperature. (Freeze frame PID data 2)	Adjust tire pressure.
FFD1_MLG (Wheel unit mileage value (freeze frame PID data 1))	m, mi (ft)	Indicates the mileage. (Freeze frame PID data 1)	Adjust tire pressure.
FFD2_MLG (Wheel unit mileage value (freeze frame PID data 2))	m, mi (ft)	Indicates the mileage. (Freeze frame PID data 2)	Adjust tire pressure.
FFD1_SPD (Wheel unit speed value (freeze frame PID data 1))	KPH, MPH	Indicates the speed. (Freeze frame PID data 1)	Adjust tire pressure.
FFD2_SPD (Wheel unit speed value (freeze frame PID data 2))	KPH, MPH	Indicates the speed. (Freeze frame PID data 2)	Adjust tire pressure.
CCNT_TPMS (Number of continuous DTCs)	-	Indicates number of DTC	Perform the DTC inspection.
ID_LAST* (Last received tire transmitter ID code value)	-	Indicates the last ID that is transmitted from the wheel unit.	<ul style="list-style-type: none"> Replace the wheel unit. Perform the configuration.
ID_WU1* ID_WU2* ID_WU3* ID_WU4* (Registered wheel unit ID code)	-	Indicates the registered ID that is transmitted from the wheel unit.	<ul style="list-style-type: none"> Replace the wheel unit. Perform the wheel unit ID registration.
SPDOMETER (Vehicle speed)	KPH, MPH	<ul style="list-style-type: none"> Vehicle is stopped: 0 KPH (0 MPH) Vehicle is running: Indicates vehicle speed 	Inspect the PCM.
VBATT (Battery positive voltage)	V	<ul style="list-style-type: none"> Ignition switch ON: B+ Ignition switch OFF: 0 V 	<ul style="list-style-type: none"> Inspect the battery. Inspect the related wiring harness.
WU1_P* WU2_P* WU3_P* WU4_P* (Tire pressure value)	Pa, psi	Indicates the tire pressure. (See 02-50-1 SUSPENSION TECHNICAL DATA.)	<ul style="list-style-type: none"> Adjust tire pressure. Replace the wheel unit.
WU1_T* WU2_T* WU3_T* WU4_T* (Internal tire air temperature value)	°C, °F	Indicates the internal tire air temperature.	Replace the wheel unit.

Active Command Modes Procedure (Article 1422124)

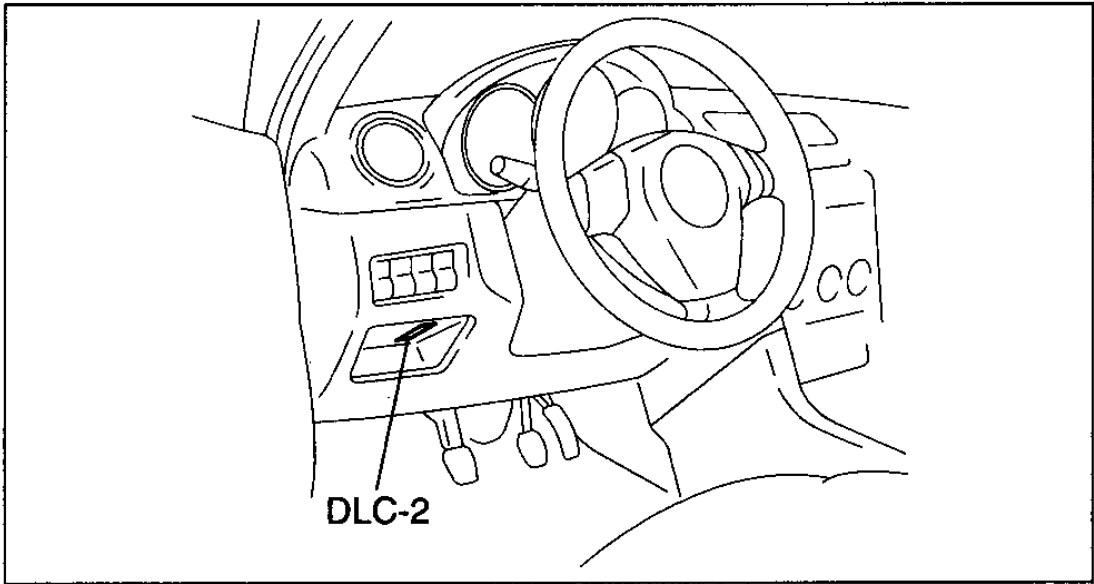

am3zzw0000168

Freeze Frame PID Data Access Procedure (Article 1422126)

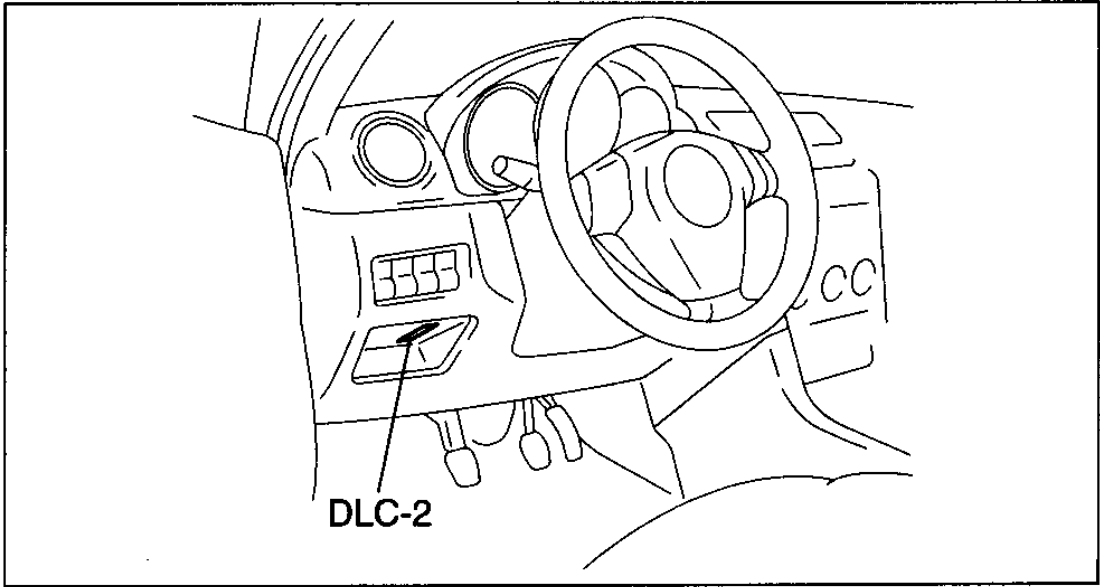

am3zzw0000168

Active Command Modes Table (Article 1422125)

Active Command Modes Table

Command Name	Definition	Operation	Note
IDR_MODE	Wheel unit ID registration mode	On/Off	Ignition switch at ON

Symptom Troubleshooting (Article 1422105)

SYMPTOM TROUBLESHOOTING

id020300800400

No.	Symptom
1	TPMS warning light illuminates continuously.
2	TPMS warning light (low pressure warning) illuminates after engine start and turns off after driving for a period of time.
3	Wheel unit ID registration cannot be performed (TPMS warning light flashes).

No.1 TPMS Warning Light Illuminates Continuously (Article 1422177)

1	TPMS warning light illuminates continuously
[TROUBLESHOOTING HINTS]	
<ul style="list-style-type: none"> Tire pressure is lower than the specification. 	

STEP	INSPECTION	ACTION
1	INSPECT THE TIRE <ul style="list-style-type: none"> Is there any foreign object adhering to the tire? 	Yes Remove any foreign object. Replace the tire if necessary, and then go to the next step.
		No Go to the next step.
2	INSPECT THE TIRE PRESSURE <ul style="list-style-type: none"> Is the tire pressure lower than the specification? 	Yes Adjust the tire pressure to the specification when the tires are cold, and then go to the next step.
		No Go to the next step.
3	DOES THE TPMS WARNING LIGHT TURN OFF?	Yes Troubleshooting completed. Explain to the customer what has been repaired.
		No Go to the next step.
4	DRIVE THE VEHICLE AT 25 KM/H FOR 10 MIN. <ul style="list-style-type: none"> Does the TPMS warning light turn off? 	Yes Troubleshooting completed. Explain to the customer what has been repaired.
		No Adjust the tire pressure to the specification, and then return to Step 1. Note <ul style="list-style-type: none"> If the TPMS warning light does not turn off after repeating this step, the tire may be flat.

No.2 TPMS Warning Light (Low Pressure Warning) Illuminates After Engine Start and Turns Off After Driving For Period of Time (Article 1422195)

2	TPMS warning light (low pressure warning) illuminates after engine start and turns off after driving for a period of time.
[TROUBLESHOOTING HINTS]	
<ul style="list-style-type: none"> The tire pressure decreases (approaches value to illuminate TPMS warning light) when the internal temperature of the tire is low. 	

STEP	INSPECTION	ACTION
1	INSPECT THE TIRE <ul style="list-style-type: none"> Is there any foreign object adhering to the tire? 	Yes Remove any foreign object. Replace the tire if necessary, and then go to the next step.
		No Go to the next step.
2	MEASURE THE TIRE PRESSURE WHEN THE TIRES ARE COLD <ul style="list-style-type: none"> Has the tire pressure decreased (approaches value to illuminate TPMS warning light)? 	Yes Adjust the tire pressure to the specification, and then go to the next step.
		No Go to the next step.
3	IS THE MALFUNCTION CORRECTED?	Yes Troubleshooting completed.
		No Verify troubleshooting again and return to Step 1 if the malfunction recurs.

No.3 Wheel Unit ID Registration Cannot Be Performed (TPMs Warning Light Flashes) (Article 1422197)

3	Wheel unit ID registration cannot be performed (TPMS warning light flashes).
[TROUBLESHOOTING HINTS]	
<ul style="list-style-type: none"> • New wheel unit malfunction (caused when installing to wheel) • Any malfunction on an old wheel unit which has not been replaced. 	

STEP	INSPECTION	ACTION
1	CAN THE WHEEL UNIT ID BE REGISTERED? <ul style="list-style-type: none"> • Connect the M-MDS. • Display the wheel unit ID registration condition (ID and tire pressure table) using the M-MDS. • Temporarily remove the battery and reinstall it immediately. Note <ul style="list-style-type: none"> • If the battery is removed, the tire pressure data for WU_1 to WU_4 stored in the instrument cluster is reset. • Pressure is 0 kPa (0 kgf/cm², 0 psi) when it is displayed again using the M-MDS. <ul style="list-style-type: none"> • Set tire pressure for the four wheels separately. • Perform the wheel unit ID registration again. • Can the ID be registered? 	Yes Trouble shooting completed. (Adjust the tire pressure on four wheels, and then return the vehicle to the customer.)
		No Go to the next step.
2	VERIFY THE WHEEL UNIT ID REGISTRATION CONDITIONS (ID AND TIRE PRESSURE TABLE) USING THE M-MDS <ul style="list-style-type: none"> • Refer to [Display Of M-MDS (Example)] to specify wheel unit for which the ID could not be registered. (See Display Of M-MDS (Example).) • Is the wheel unit for which the ID could not be registered a new wheel unit? Caution <ul style="list-style-type: none"> • ID numbers of WU_1 to WU_4 are updated when wheel on all of four wheels are registered. 	Yes Replace with a new wheel unit, and then go to Step 4.
		No Go to the next step.
3	Replace the old wheel unit, and then go to the next step (any malfunction on an old wheel unit which has not been replaced).	
4	CAN THE WHEEL UNIT ID BE REGISTERED? <ul style="list-style-type: none"> • Perform the wheel unit ID registration using the M-MDS. 	Yes Troubleshooting completed.
		No Verify troubleshooting again and return to Step 1 if the malfunction recurs.

Three registered wheel units and a replaced wheel unit When a replaced wheel unit malfunctions

	WU_1	WU_2	WU_3	WU_4
ID Number (Stored)	0xAAAAAAAA	0xBBBBBBBB	0xCCCCCCCC	0xDDDDDDDD
ID Number (Candidate)	0x00000000	0x00000000	0x00000000	0x00000000
Tire Pressure (Stored)	aaa kPa	bbb kPa	ccc kPa	0 kPa
Tire Pressure (Candidate)	0 kPa	0 kPa	0 kPa	0 kPa

When a registered wheel unit malfunctions

	WU_1	WU_2	WU_3	WU_4
ID Number (Stored)	0xAAAAAAAA	0xBBBBBBBB	0xCCCCCCCC	0xDDDDDDDD
ID Number (Candidate)	0xEEEEEEEE	0x00000000	0x00000000	0x00000000
Tire Pressure (Stored)	aaa kPa	bbb kPa	0 kPa	0 kPa
Tire Pressure (Candidate)	eee kPa	0 kPa	0 kPa	0 kPa

When two registered wheel unit malfunction

	WU_1	WU_2	WU_3	WU_4
ID Number (Stored)	0xAAAAAAAA	0xBBBBBBBB	0xCCCCCCCC	0xDDDDDDDD
ID Number (Candidate)	0xEEEEEEEE	0x00000000	0x00000000	0x00000000
Tire Pressure (Stored)	aaa kPa	0 kPa	0 kPa	0 kPa
Tire Pressure (Candidate)	eee kPa	0 kPa	0 kPa	0 kPa

When a replaced wheel unit and a registered wheel unit malfunction

	WU_1	WU_2	WU_3	WU_4
ID Number (Stored)	0xAAAAAAAA	0xBBBBBBBB	0xCCCCCCCC	0xDDDDDDDD
ID Number (Candidate)	0x00000000	0x00000000	0x00000000	0x00000000
Tire Pressure (Stored)	aaa kPa	bbb kPa	0 kPa	0 kPa
Tire Pressure (Candidate)	0 kPa	0 kPa	0 kPa	0 kPa

When a replaced wheel unit and two registered wheel units malfunctions

	WU_1	WU_2	WU_3	WU_4
ID Number (Stored)	0xAAAAAAAA	0xBBBBBBBB	0xCCCCCCCC	0xDDDDDDDD
ID Number (Candidate)	0x00000000	0x00000000	0x00000000	0x00000000
Tire Pressure (Stored)	aaa kPa	0 kPa	0 kPa	0 kPa
Tire Pressure (Candidate)	0 kPa	0 kPa	0 kPa	0 kPa

When three registered wheel units malfunction

	WU_1	WU_2	WU_3	WU_4
ID Number (Stored)	0xAAAAAAAA	0xBBBBBBBB	0xCCCCCCCC	0xDDDDDDDD
ID Number (Candidate)	0xEEEEEEEE	0x00000000	0x00000000	0x00000000
Tire Pressure (Stored)	0 kPa	0 kPa	0 kPa	0 kPa
Tire Pressure (Candidate)	eee kPa	0 kPa	0 kPa	0 kPa

Two registered wheel units and two replaced wheel units

When a replaced wheel unit malfunctions

	WU_1	WU_2	WU_3	WU_4
ID Number (Stored)	0xAAAAAAAA	0xBBBBBBBB	0xCCCCCCCC	0xDDDDDDDD
ID Number (Candidate)	0xEEEEEEEE	0x00000000	0x00000000	0x00000000
Tire Pressure (Stored)	aaa kPa	bbb kPa	0 kPa	0 kPa
Tire Pressure (Candidate)	eee kPa	0 kPa	0 kPa	0 kPa

When a registered wheel unit malfunctions

	WU_1	WU_2	WU_3	WU_4
ID Number (Stored)	0xAAAAAAAA	0xBBBBBBBB	0xCCCCCCCC	0xDDDDDDDD
ID Number (Candidate)	0xEEEEEEEE	0xFFFFFFFF	0x00000000	0x00000000
Tire Pressure (Stored)	aaa kPa	0 kPa	0 kPa	0 kPa
Tire Pressure (Candidate)	eee kPa	fff kPa	0 kPa	0 kPa

When two replaced wheel units malfunction

	WU_1	WU_2	WU_3	WU_4
ID Number (Stored)	0xAAAAAAAA	0xBBBBBBBB	0xCCCCCCCC	0xDDDDDDDD
ID Number (Candidate)	0x00000000	0x00000000	0x00000000	0x00000000
Tire Pressure (Stored)	aaa kPa	bbb kPa	0 kPa	0 kPa
Tire Pressure (Candidate)	0 kPa	0 kPa	0 kPa	0 kPa

When two registered wheel units malfunction

	WU_1	WU_2	WU_3	WU_4
ID Number (Stored)	0xAAAAAAAA	0xBBBBBBBB	0xCCCCCCCC	0xDDDDDDDD
ID Number (Candidate)	0xEEEEEEEE	0xFFFFFFFF	0x00000000	0x00000000
Tire Pressure (Stored)	0 kPa	0 kPa	0 kPa	0 kPa
Tire Pressure (Candidate)	eee kPa	fff kPa	0 kPa	0 kPa

When a replaced wheel unit and a registered wheel unit malfunction

	WU_1	WU_2	WU_3	WU_4
ID Number (Stored)	0xAAAAAAAA	0xBBBBBBBB	0xCCCCCCC	0xDDDDDDDD
ID Number (Candidate)	0xEEEEEEEE	0x00000000	0x00000000	0x00000000
Tire Pressure (Stored)	aaa kPa	0 kPa	0 kPa	0 kPa
Tire Pressure (Candidate)	eee kPa	0 kPa	0 kPa	0 kPa

When two replaced wheel units and a registered wheel unit malfunction

	WU_1	WU_2	WU_3	WU_4
ID Number (Stored)	0xAAAAAAAA	0xBBBBBBBB	0xCCCCCCC	0xDDDDDDDD
ID Number (Candidate)	0x00000000	0x00000000	0x00000000	0x00000000
Tire Pressure (Stored)	aaa kPa	0 kPa	0 kPa	0 kPa
Tire Pressure (Candidate)	0 kPa	0 kPa	0 kPa	0 kPa

When a replaced wheel unit and two registered wheel units malfunction

	WU_1	WU_2	WU_3	WU_4
ID Number (Stored)	0xAAAAAAAA	0xBBBBBBBB	0xCCCCCCC	0xDDDDDDDD
ID Number (Candidate)	0xEEEEEEEE	0x00000000	0x00000000	0x00000000
Tire Pressure (Stored)	0 kPa	0 kPa	0 kPa	0 kPa
Tire Pressure (Candidate)	eee kPa	0 kPa	0 kPa	0 kPa

A registered wheel unit and three replaced wheel units**When a registered wheel unit malfunctions**

	WU_1	WU_2	WU_3	WU_4
ID Number (Stored)	0xAAAAAAAA	0xBBBBBBBB	0xCCCCCCC	0xDDDDDDDD
ID Number (Candidate)	0xEEEEEEEE	0xFFFFFFFF	0xGGGGGGGG	0x00000000
Tire Pressure (Stored)	0 kPa	0 kPa	0 kPa	0 kPa
Tire Pressure (Candidate)	eee kPa	fff kPa	ggg kPa	0 kPa

When a replaced wheel unit malfunctions

	WU_1	WU_2	WU_3	WU_4
ID Number (Stored)	0xAAAAAAAA	0xBBBBBBBB	0xCCCCCCC	0xDDDDDDDD
ID Number (Candidate)	0xEEEEEEEE	0xFFFFFFFF	0x00000000	0x00000000
Tire Pressure (Stored)	aaa kPa	0 kPa	0 kPa	0 kPa
Tire Pressure (Candidate)	eee kPa	fff kPa	0 kPa	0 kPa

When a replaced wheel unit and a registered wheel unit malfunction

	WU_1	WU_2	WU_3	WU_4
ID Number (Stored)	0xAAAAAAAA	0xBBBBBBBB	0xCCCCCCC	0xDDDDDDDD
ID Number (Candidate)	0xEEEEEEEE	0xFFFFFFFF	0x00000000	0x00000000
Tire Pressure (Stored)	0 kPa	0 kPa	0 kPa	0 kPa
Tire Pressure (Candidate)	eee kPa	fff kPa	0 kPa	0 kPa

When two replaced wheel units malfunction

	WU_1	WU_2	WU_3	WU_4
ID Number (Stored)	0xAAAAAAAA	0xBBBBBBBB	0xCCCCCCC	0xDDDDDDDD
ID Number (Candidate)	0xEEEEEEEE	0x00000000	0x00000000	0x00000000
Tire Pressure (Stored)	aaa kPa	0 kPa	0 kPa	0 kPa
Tire Pressure (Candidate)	eee kPa	0 kPa	0 kPa	0 kPa

When two replaced wheel units and a registered wheel unit malfunction

	WU_1	WU_2	WU_3	WU_4
ID Number (Stored)	0xAAAAAAAA	0xBBBBBBBB	0xCCCCCCCC	0xDDDDDDDD
ID Number (Candidate)	0xEEEEEEEE	0x00000000	0x00000000	0x00000000
Tire Pressure (Stored)	0 kPa	0 kPa	0 kPa	0 kPa
Tire Pressure (Candidate)	eee kPa	0 kPa	0 kPa	0 kPa

When three replaced wheel units malfunction

	WU_1	WU_2	WU_3	WU_4
ID Number (Stored)	0xAAAAAAAA	0xBBBBBBBB	0xCCCCCCCC	0xDDDDDDDD
ID Number (Candidate)	0x00000000	0x00000000	0x00000000	0x00000000
Tire Pressure (Stored)	aaa kPa	0 kPa	0 kPa	0 kPa
Tire Pressure (Candidate)	0 kPa	0 kPa	0 kPa	0 kPa