

# **Component Procedures: Horn**

## **Table of Contents**

1. Parts and Labor (itype\_189)
2. Electrical (OE) (itype\_21)
3. Horns (Article 14662)
4. Removal and Replacement (itype\_401)

# Component Procedures: Horn

## Parts and Labor (itype\_189)

### Parts

Qualifier	Part #	Name	Price	Note
Horn	BN8P6678Y	Horn	55.99	

### Labor

Operation	Qualifier Path	Skill	Std Hrs	Wty Hrs
Replace	One	B	0.6	0.4
Replace	Two	B	0.7	0.5

## Electrical (OE) (itype\_21)

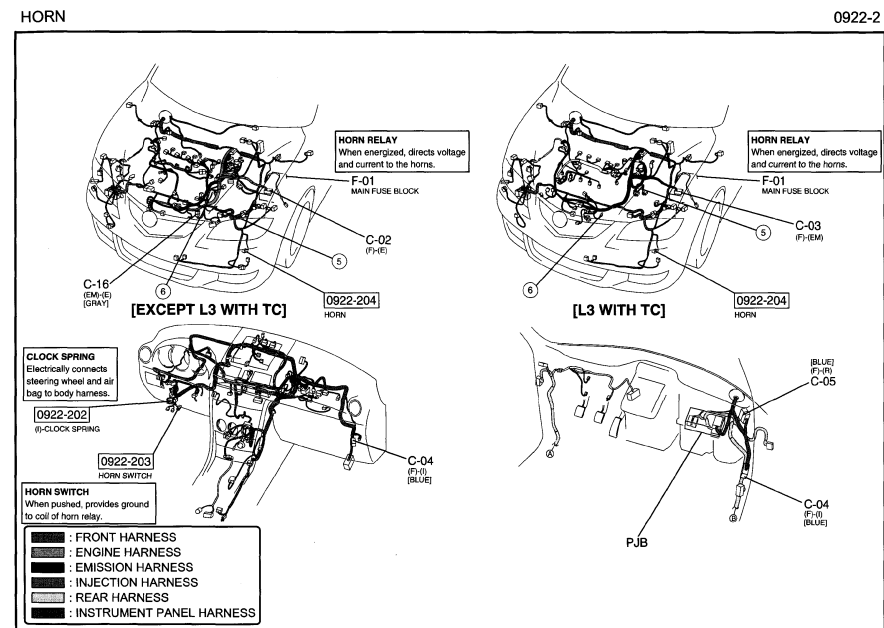
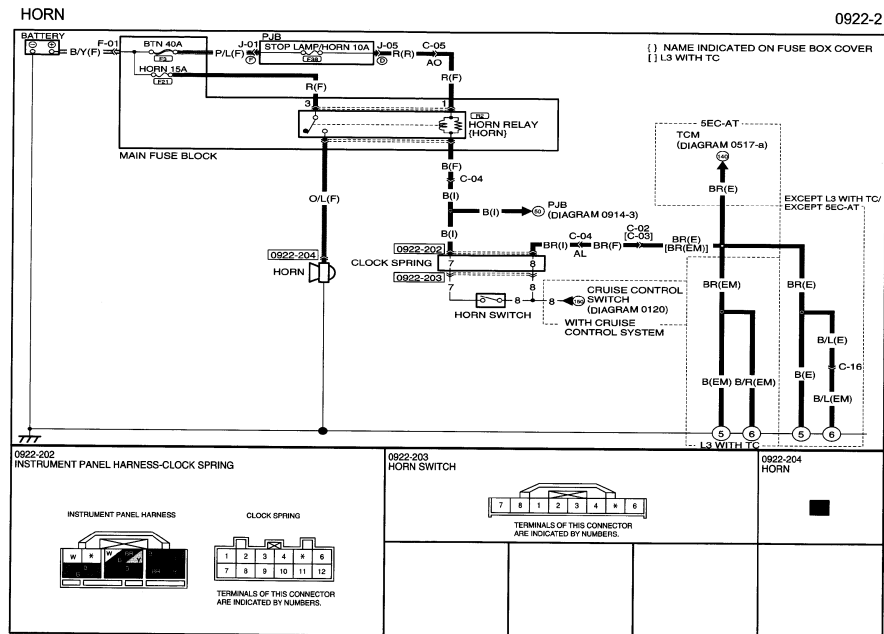

## Horns (Article 14662)

Horns  
Page 1 of 1

### Removal and Replacement (itype\_401)

1	Bolt
2	Connector
3	Horn

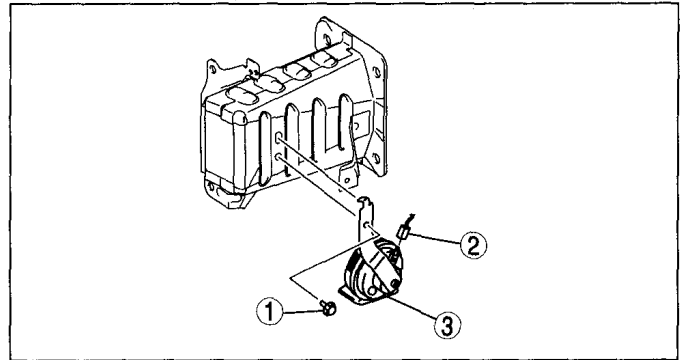

c3u0922w102