

Component Procedures: Headlamp

Table of Contents

1. Headlight Aiming (Article 1359448)
2. Parts and Labor (itype_189)
3. Headlight (Without DRL) (Article 1388179)
4. Headlight (With DRL) (Article 1388180)
5. Headlight Manual Leveling System (Article 1388181)
6. Headlights - W/ DRL (Article 15931)
7. Headlights - W/O DRL (Article 15924)
8. Front Combination Light (Article 1423271)
9. Front Combination Light Bracket (Article 1423272)
10. All Technical Service Bulletins (itype_100)
11. Repair Tips (itype_110)
12. Out of specification (itype_158)

Component Procedures: Headlamp

Headlight Aiming (Article 1359448)

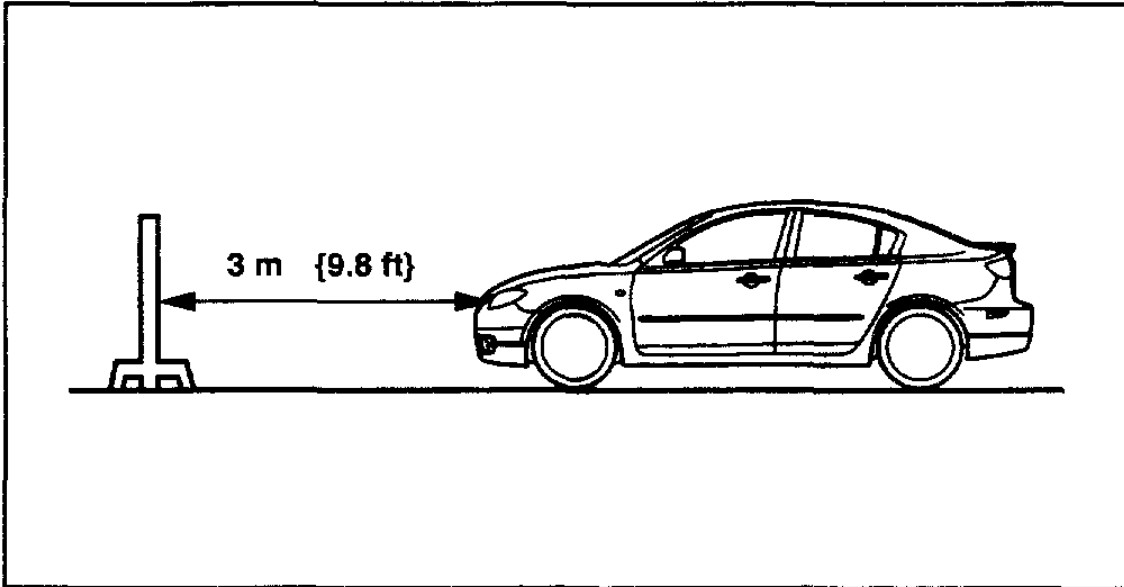

B3E0918W103

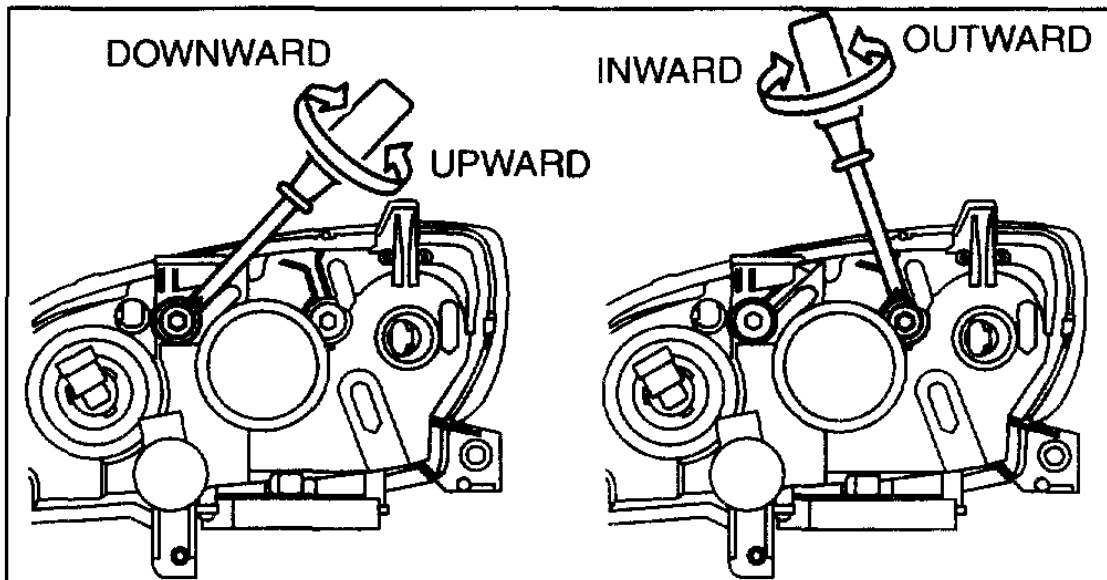

B3E0918W104

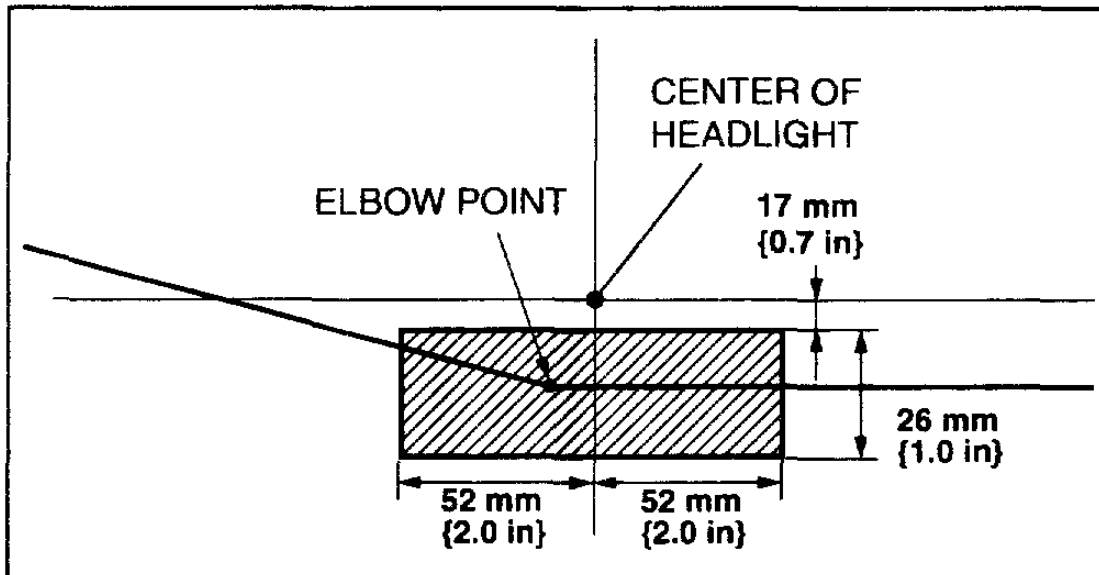

B3E0918W174

Parts and Labor (itype_189)

Parts

| Qualifier | Part # | Name | Price | Note |
|-------------------------------|------------|--------------------|---------|------|
| Composite Headlamp > 4 Door ? | BN8P510K0C | Composite Headlamp | 246.84 | |
| Composite Headlamp > 4 Door ? | BN8R51031C | Composite Headlamp | 873.41 | |
| Composite Headlamp > 4 Door ? | BN8P510L0C | Composite Headlamp | 246.82 | |
| Composite Headlamp > 4 Door ? | BN8R51041C | Composite Headlamp | 1281.07 | |
| Composite Headlamp > 5 Door ? | BN8F510K0E | Composite Headlamp | 395.41 | |
| Composite Headlamp > 5 Door ? | BN8G51031E | Composite Headlamp | 1277.82 | |
| Composite Headlamp > 5 Door ? | BN8F510L0E | Composite Headlamp | 395.41 | |
| Composite Headlamp > 5 Door ? | BN8G51041E | Composite Headlamp | 1277.82 | |

Labor

| Operation | Qualifier Path | Skill | Std Hrs | Wty Hrs |
|-----------|---------------------------------|-------|---------|---------|
| Align | One Side | C | 0.5 | 0.3 |
| Align | Both Sides | C | 0.7 | 0.4 |
| Replace | One Side | B | 0.9 | 0.7 |
| Replace | Both Sides | B | 1.3 | 1.0 |
| Replace | Composite Assembly > One Side | B | 0.9 | 0.7 |
| Replace | Composite Assembly > Both Sides | B | 1.3 | 1.0 |

Headlight (Without DRL) (Article 1388179)

HEADLIGHT (WITHOUT DRL)

0918-1a

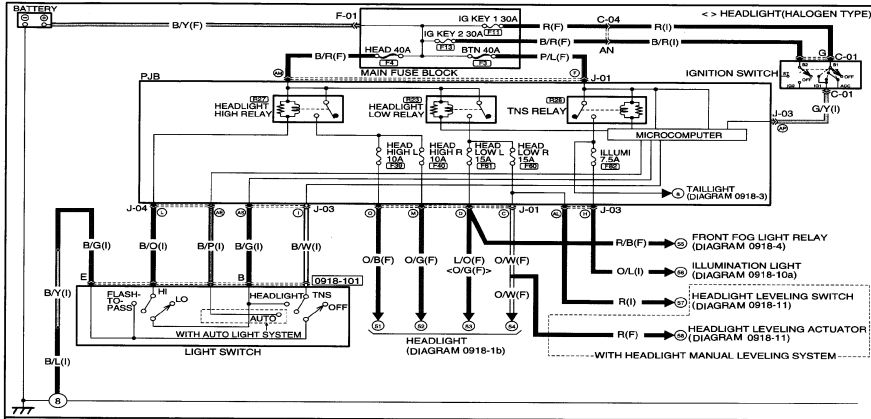

0918-101 LIGHT SWITCH

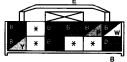

HEADLIGHT (WITHOUT DRL)

0918-1a

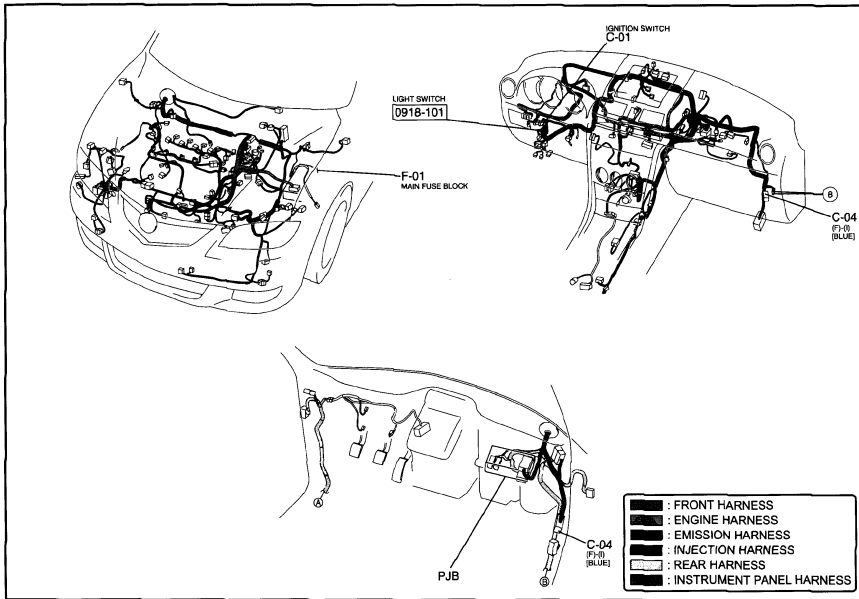

HEADLIGHT (WITHOUT DRL)

0918-1b

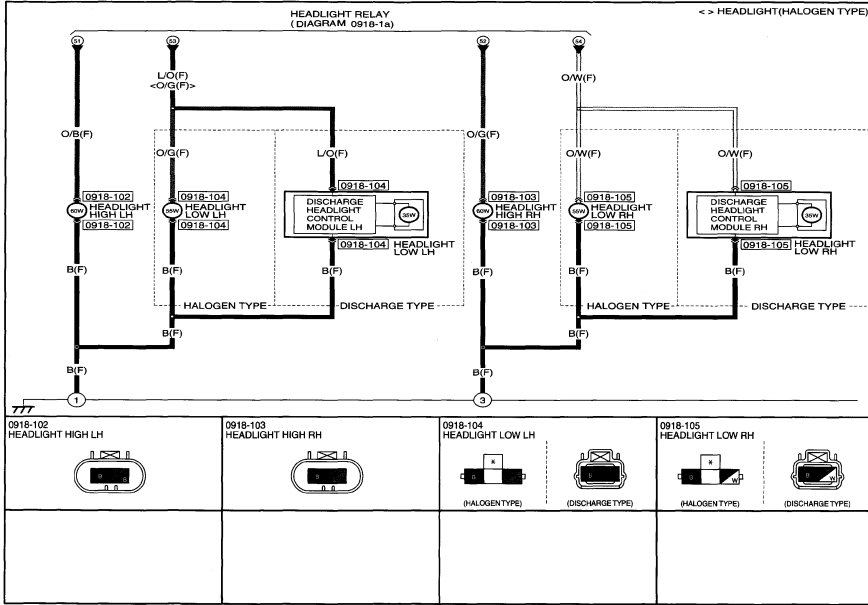

HEADLIGHT (WITHOUT DRL)

0918-1b

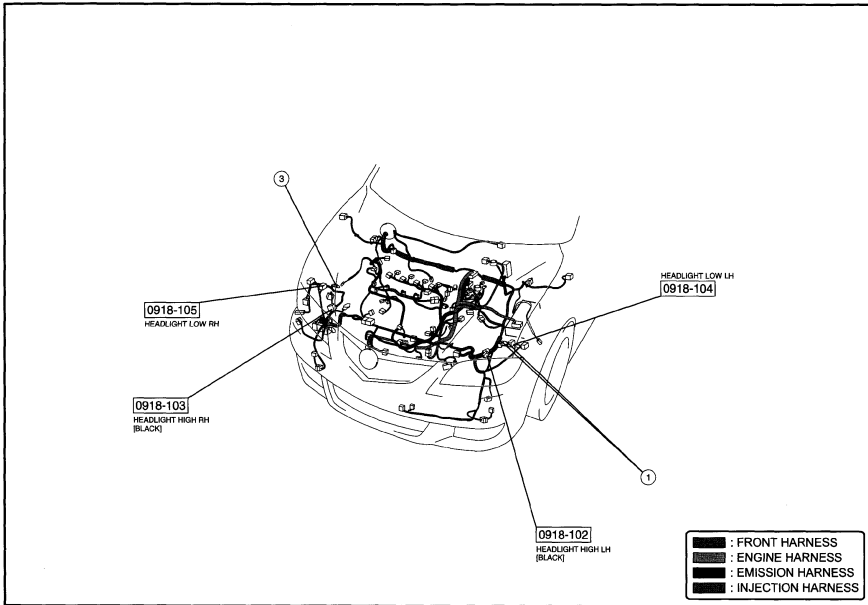

Headlight (With DRL) (Article 1388180)

HEADLIGHT (WITH DRL)

0918-2a

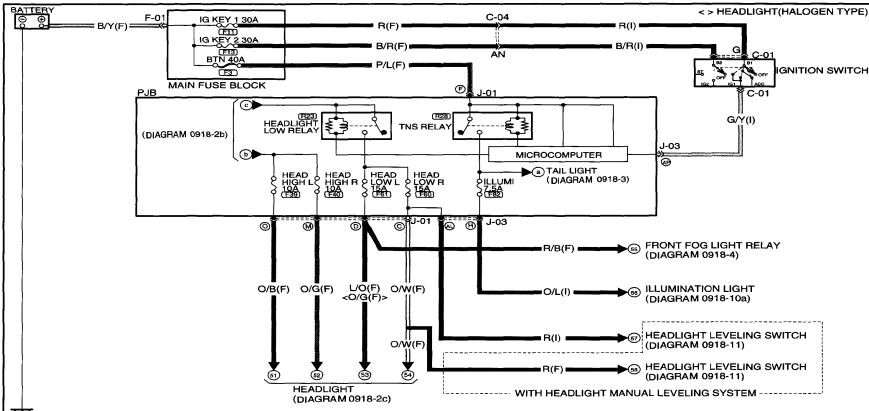

| | | | | | |
|--|--|--|--|--|--|
| | | | | | |
| | | | | | |
| | | | | | |

HEADLIGHT (WITH DRL)

0918-2a

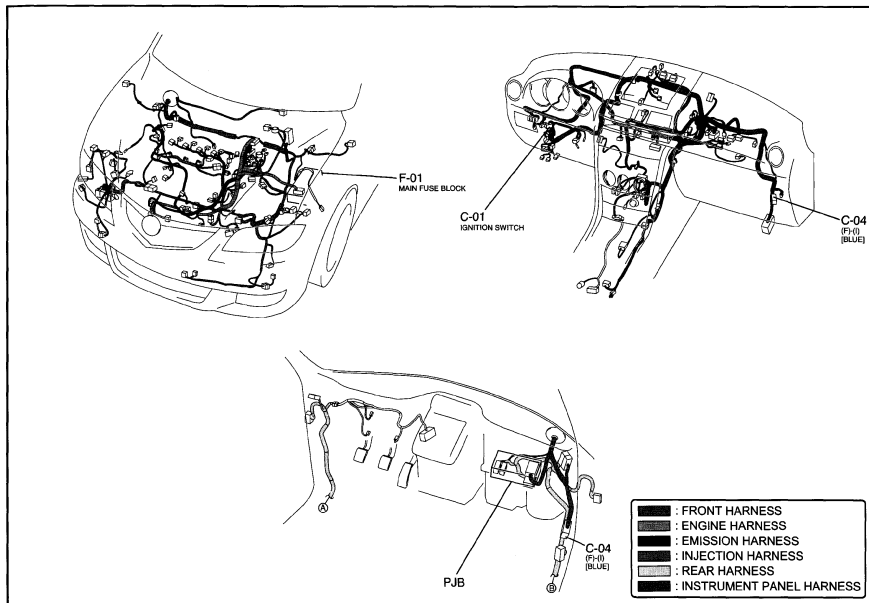

HEADLIGHT (WITH DRL)

0918-2b

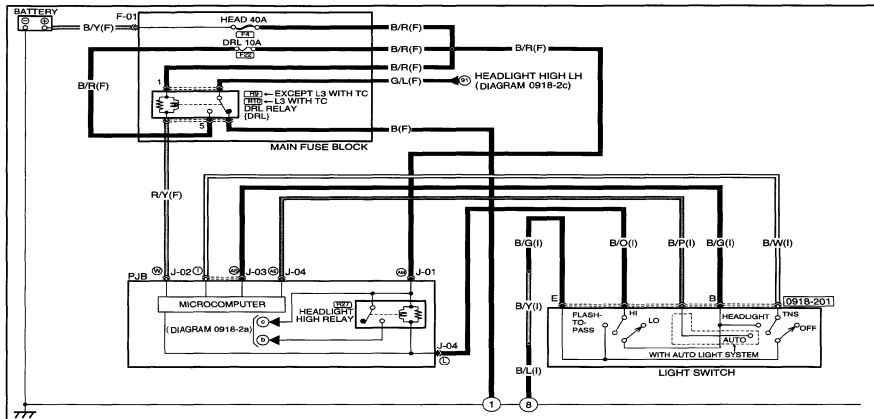

0918-201 LIGHT SWITCH

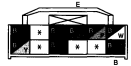

HEADLIGHT (WITH DRL)

0918-2b

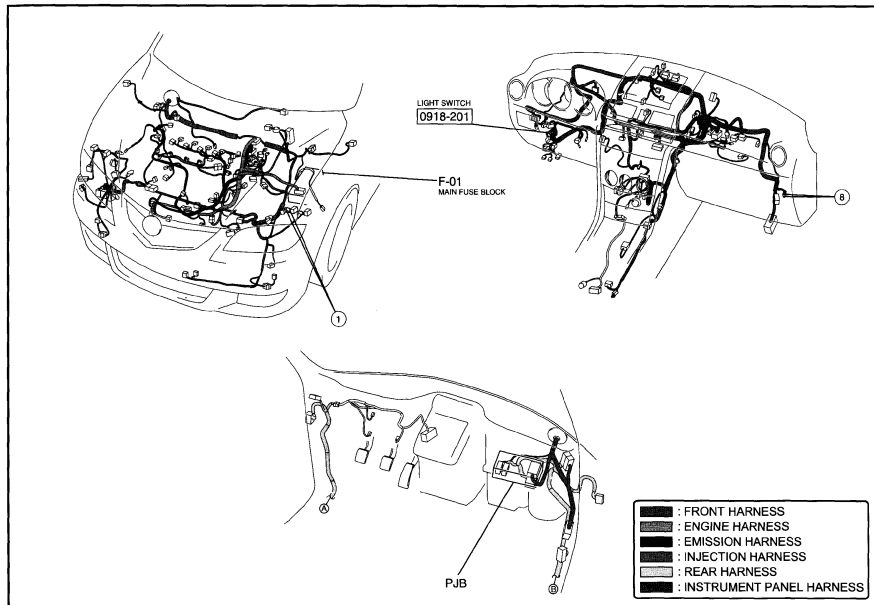

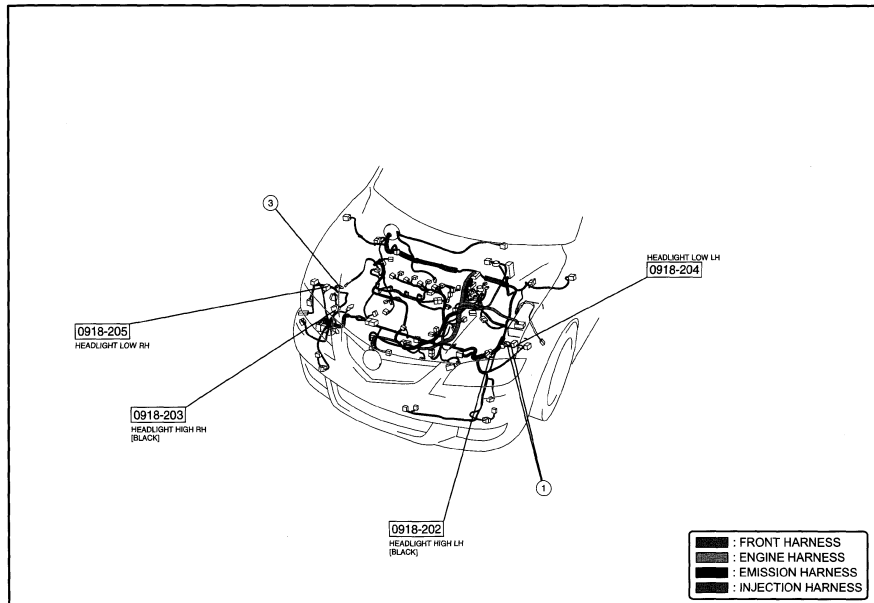
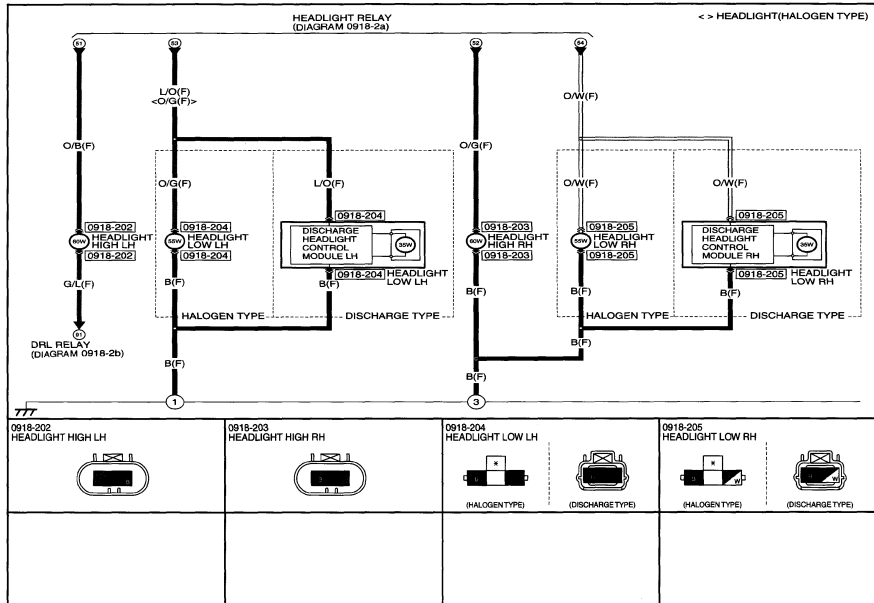

Headlight Manual Leveling System (Article 1388181)

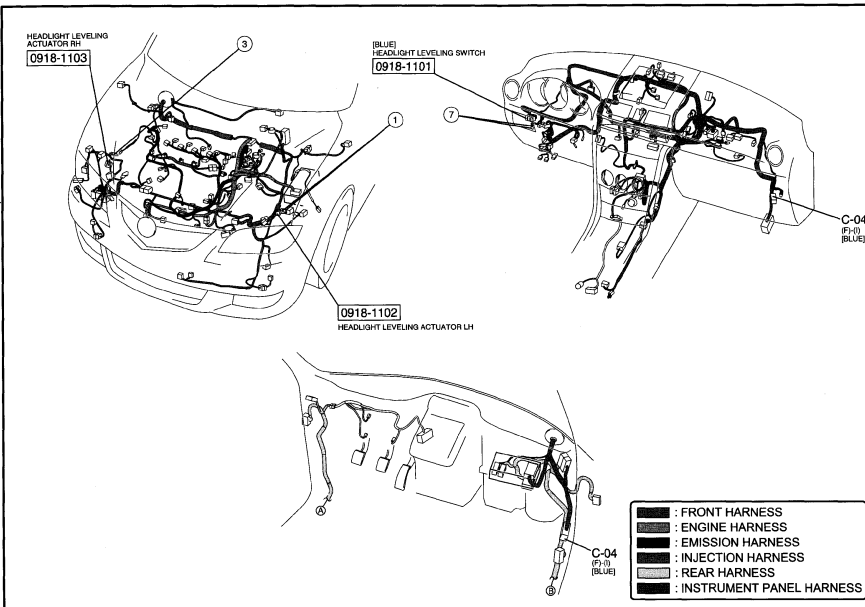
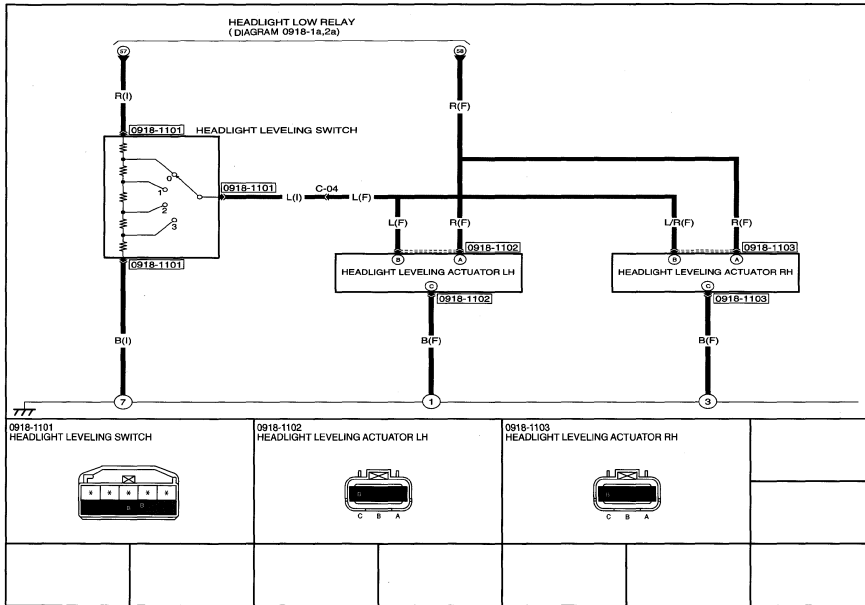

Headlights - W/ DRL (Article 15931)

Headlights - W/ DRL

Page 1 of 1

Headlights - W/O DRL (Article 15924)

Headlights - W/O DRL

Page 1 of 1

Front Combination Light (Article 1423271)

| | |
|---|-------------------------|
| 1 | Bolt A |
| 2 | Fastener |
| 3 | Bolt B |
| 4 | Front combination light |
| 5 | Connector |
| 6 | Bolt C |
| 7 | Cover |
| 8 | Bolt D (Mazdaspeed3) |
| 9 | Bracket (Mazdaspeed3) |

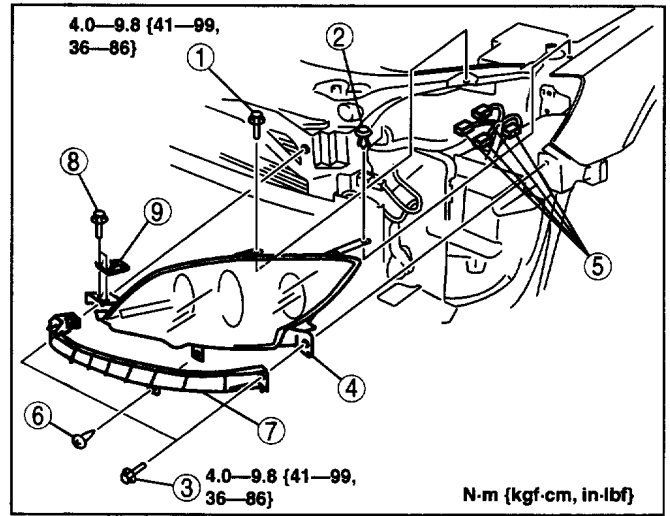

am3uuw000006

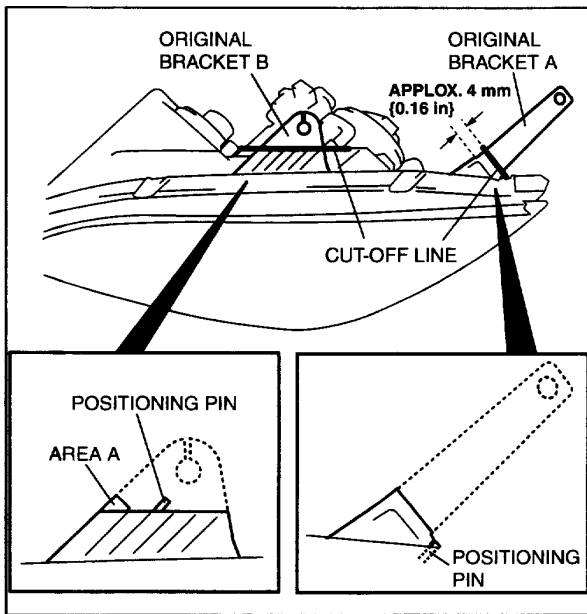

B3A918ZW1001

Front Combination Light Bracket (Article 1423272)

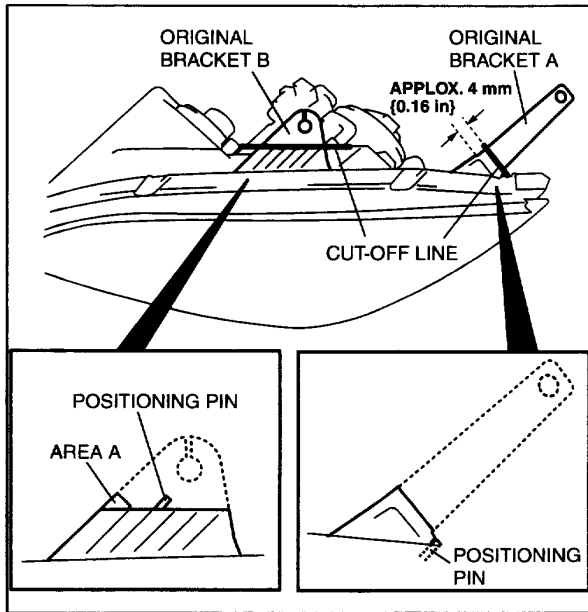

B3A918ZW1001

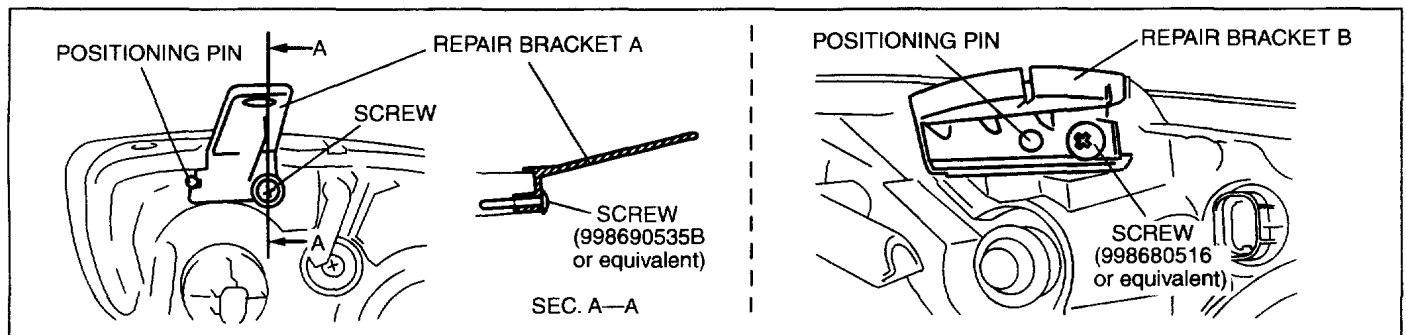

B3A918ZW1002

All Technical Service Bulletins (itype_100)

Tsbs

- Lighting - Condensation in Front or Rear Combo Lights (0900316, 2016/01/25)
- Lighting - Plastic Headlamp Lens Maintenance Cautions (0903509, 2009/07/10)
- CONDENSATION / FOG IN FRONT AND REAR COMBINATION LAMPS (HEADLAMP AND TAILLAMP ASSEMBLIES) (09-003/19, 2019/03/15)

Repair Tips (itype_110)

Tsbs

- Lighting - Condensation in Front or Rear Combo Lights (0900316, 2016/01/25)
- Lighting - Plastic Headlamp Lens Maintenance Cautions (0903509, 2009/07/10)

Out of specification (itype_158)

Tsbs

- CONDENSATION / FOG IN FRONT AND REAR COMBINATION LAMPS (HEADLAMP AND TAILLAMP ASSEMBLIES) (09-003/19, 2019/03/15)