

Component Procedures: Hose/Line HVAC

Table of Contents

1. Parts and Labor (itype_189)
2. Removal and Replacement (itype_401)

Component Procedures: Hose/Line HVAC

Parts and Labor (itype_189)

Parts

Qualifier	Part #	Name	Price	Note
Discharge Hose	BP4S614G0D	Discharge Hose	152.16	
Suction Hose > To 10/13/08	BP4S61462C	Suction Hose	81.47	

Labor

Operation	Qualifier Path	Skill	Std Hrs	Wty Hrs
Replace	Discharge Hose	B	0.7	0.4
Replace	Suction Hose	B	0.9	0.6

Removal and Replacement (itype_401)

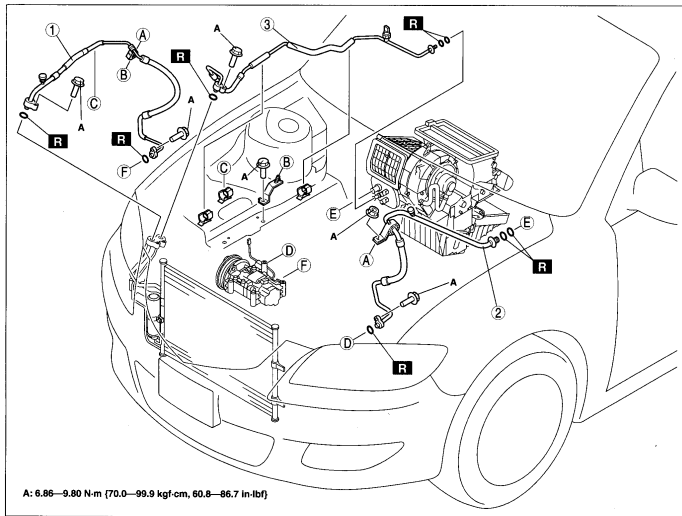

1	Cooler hose (Hi)
2	Cooler hose (Lo)

3	Cooler pipe
---	-------------

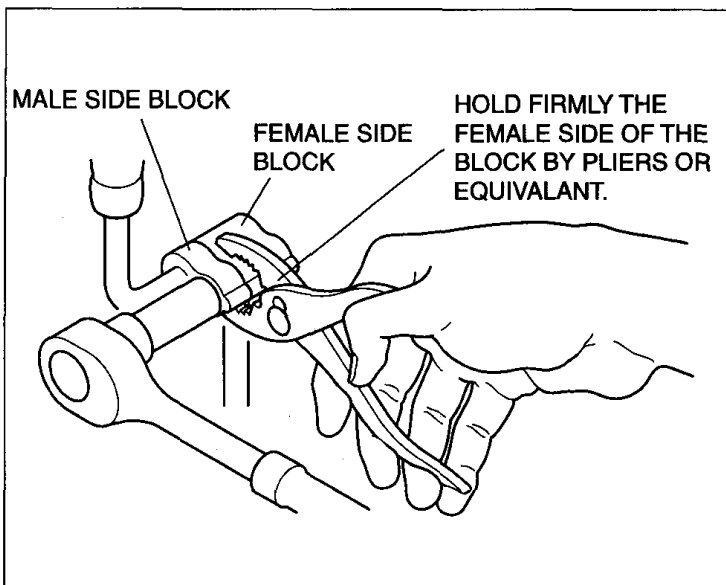

am3uuw000061

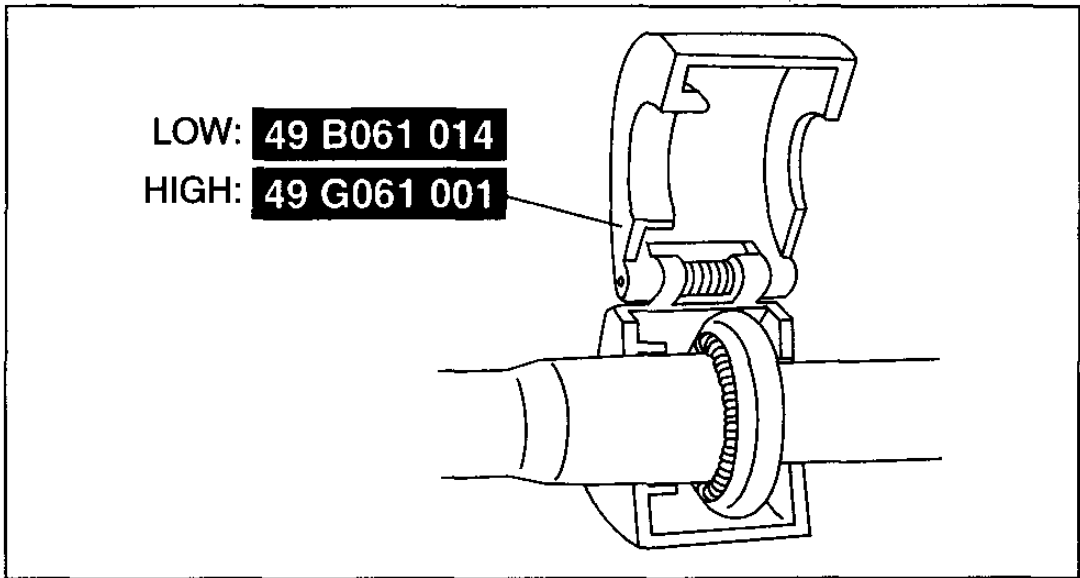

am3zzw0000072

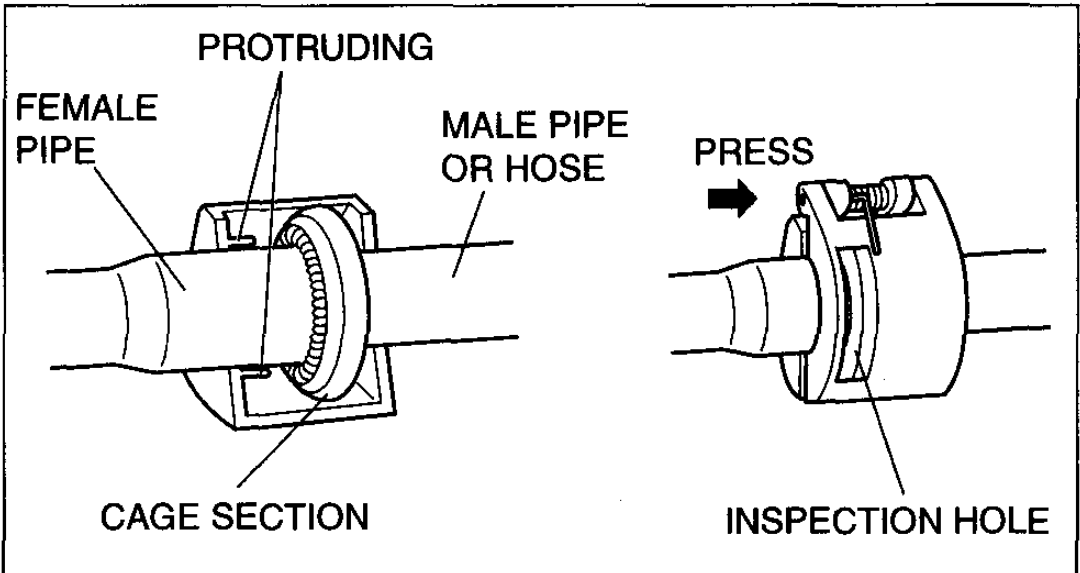

am3zzw0000072

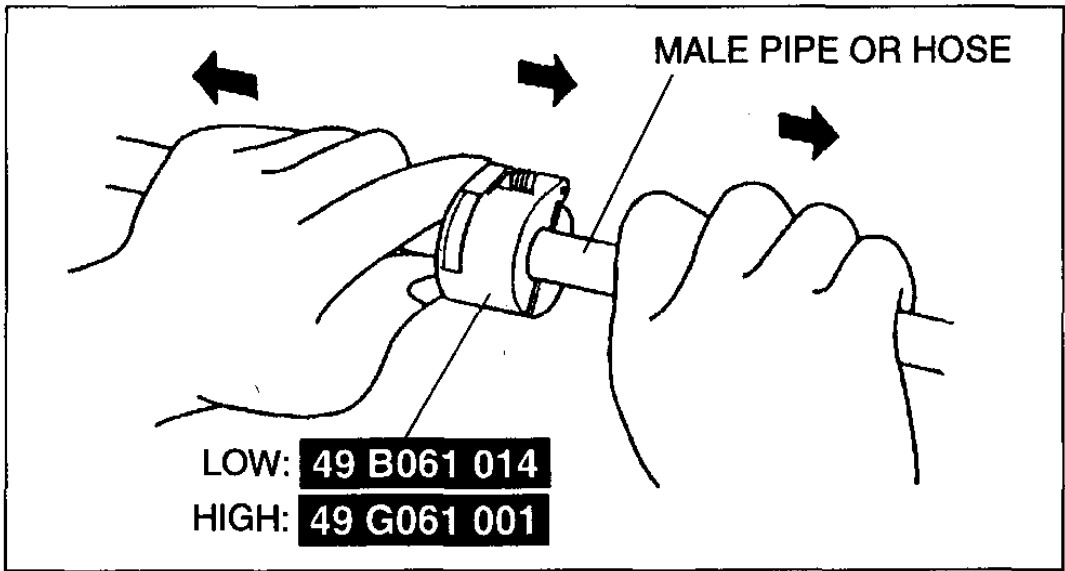

am3uuw0000061

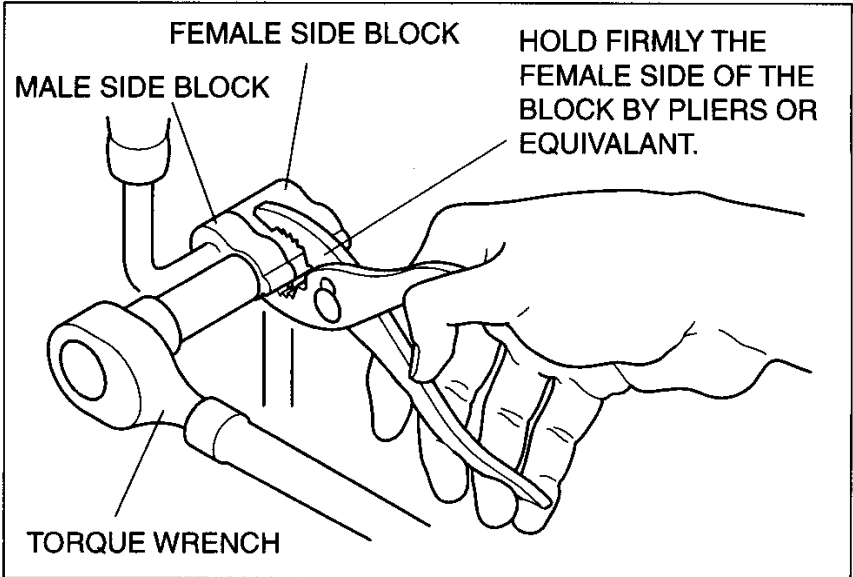

am3uuw0000061

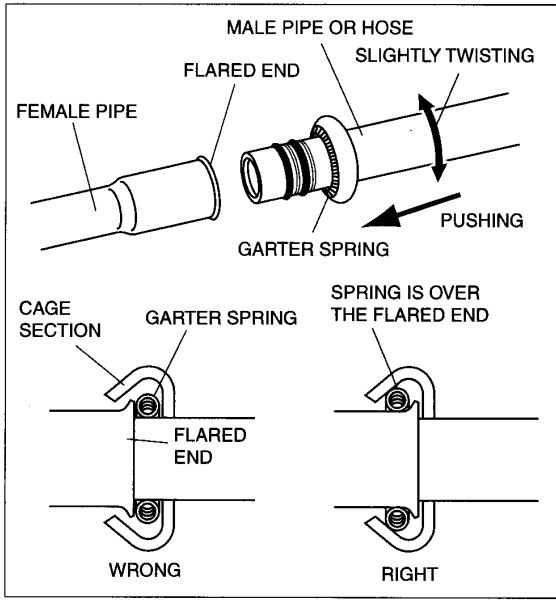

am3uuw0000062