

Component Procedures: Harmonic Balancer - Crankshaft Pulley

Table of Contents

1. Parts and Labor (itype_189)
2. Mechanical (including Torque) (itype_28)
3. All Technical Service Bulletins (itype_100)
4. Repair Tips (itype_110)

Component Procedures: Harmonic Balancer - Crankshaft Pulley

Parts and Labor (itype_189)

Parts

Qualifier	Part #	Name	Price	Note
Pulley > Manual Trans	L34N11400	Pulley	146.45	
Pulley > Auto Trans	LFR511400	Pulley	265.00	

Labor

Operation	Qualifier Path	Skill	Std Hrs	Wty Hrs
Replace	Pulley	B	1.9	1.4

Mechanical (including Torque) (itype_28)

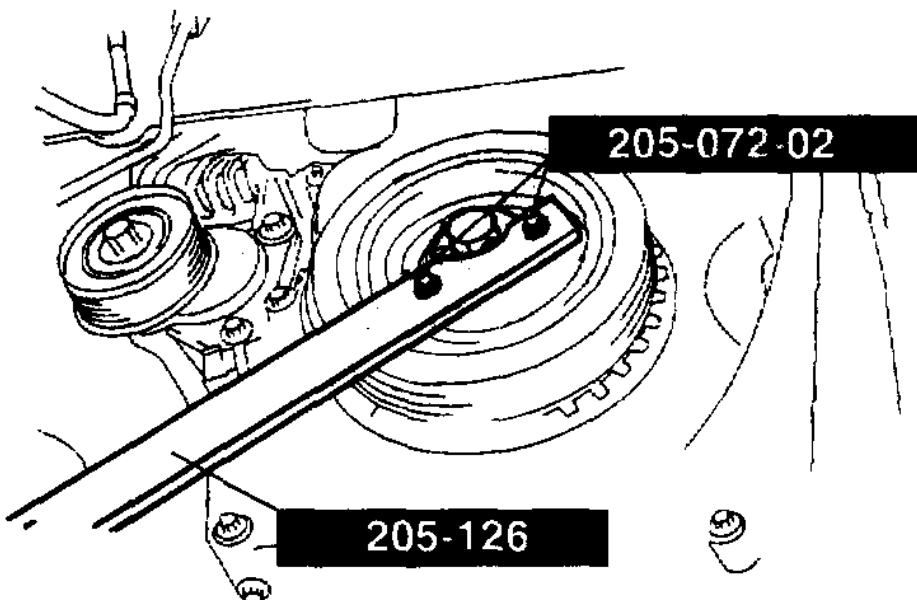
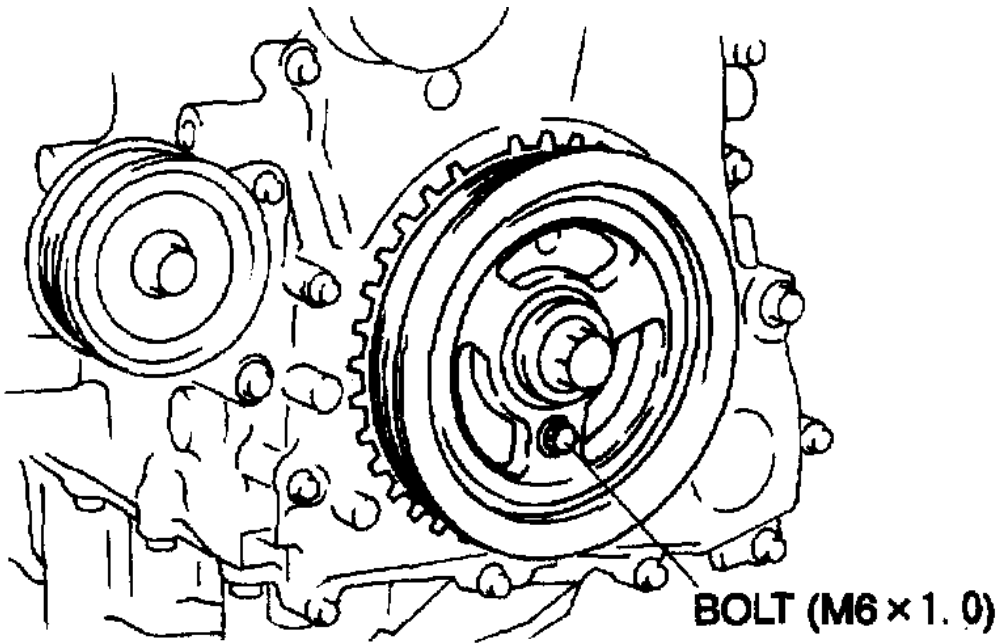

All Technical Service Bulletins (itype_100)

Tsbs

- Engine - Front Crankshaft Bolt Service Precautions (0104007, 2007/10/03)

Repair Tips (itype_110)

Tsbs

- Engine - Front Crankshaft Bolt Service Precautions (0104007, 2007/10/03)