

Component Procedures: Quarter Window Glass

Table of Contents

1. Removal and Replacement (itype_401)
2. All Technical Service Bulletins (itype_100)
3. Repair Tips (itype_110)

Component Procedures: Quarter Window Glass

Removal and Replacement (itype_401)

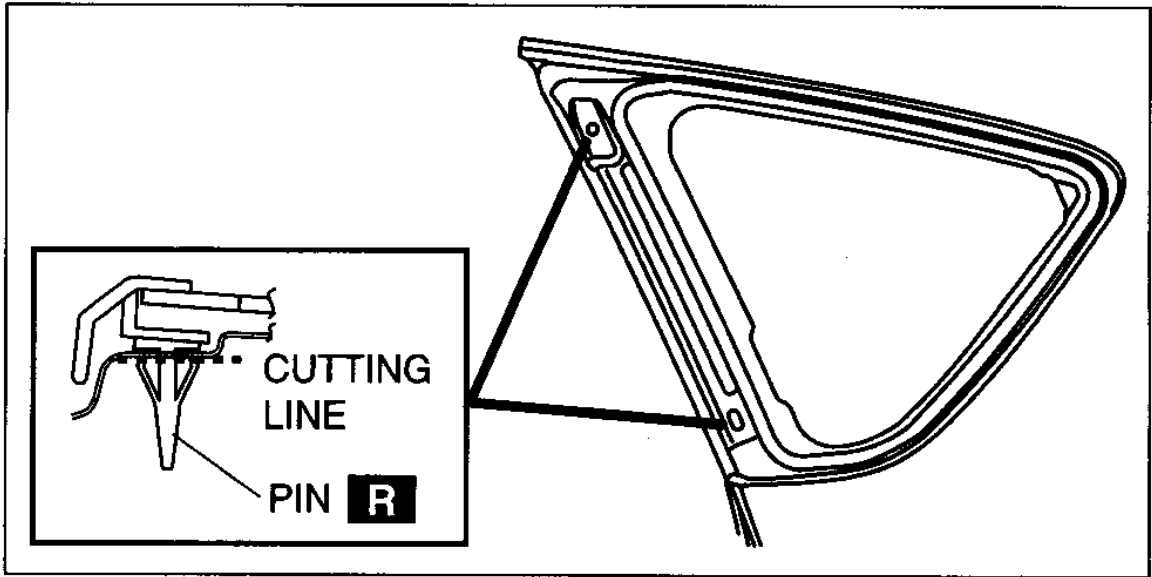

am3uuw0000137

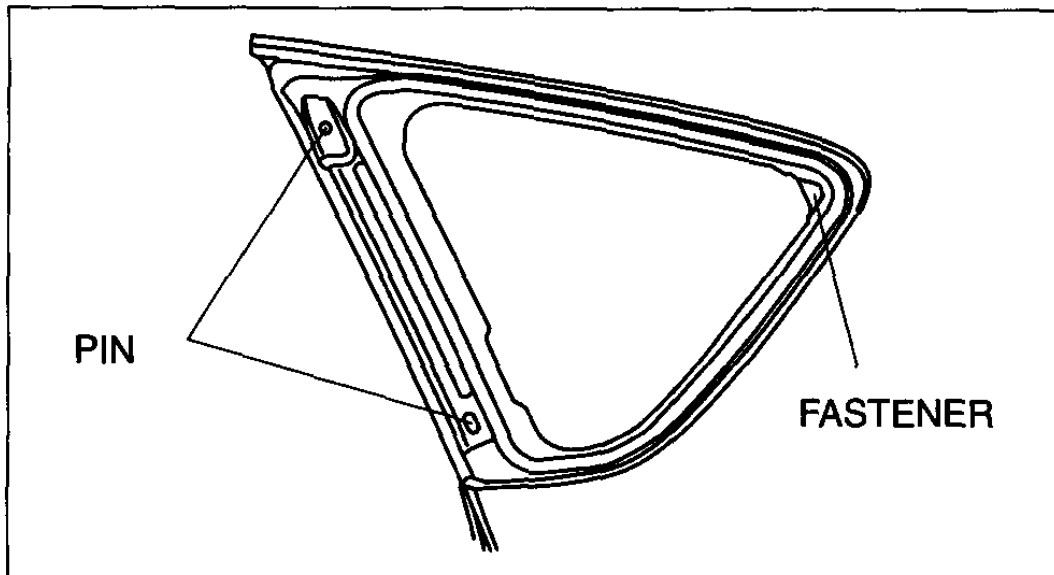

am3uuw0000137

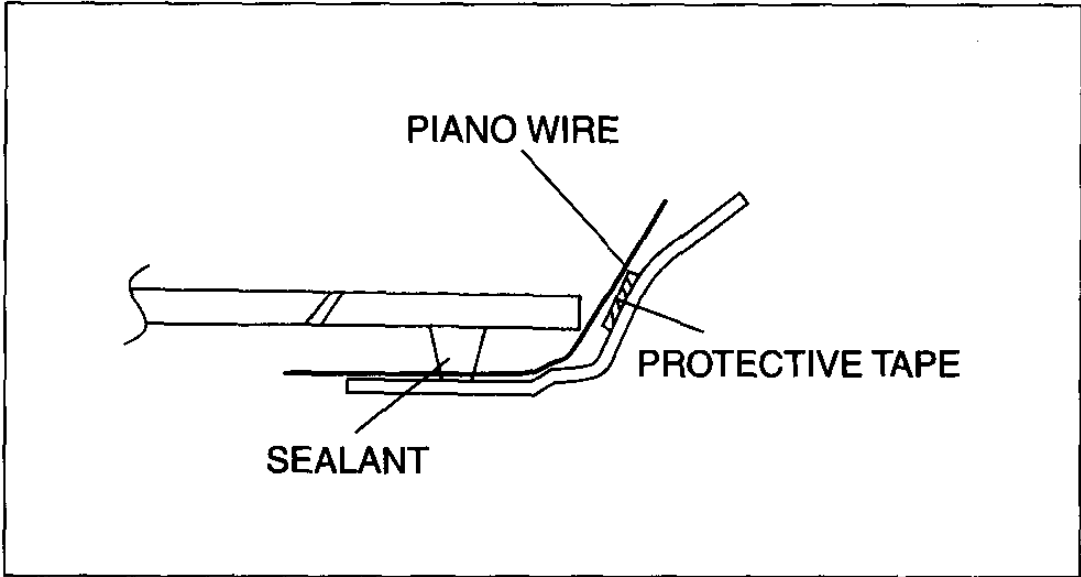

am3uuw0000137

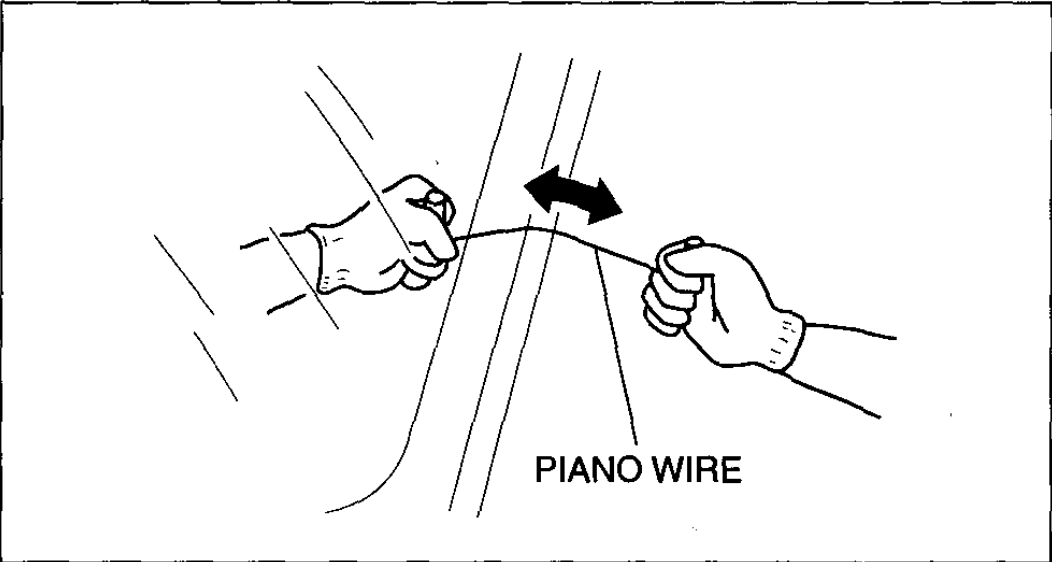

am3uuw0000137

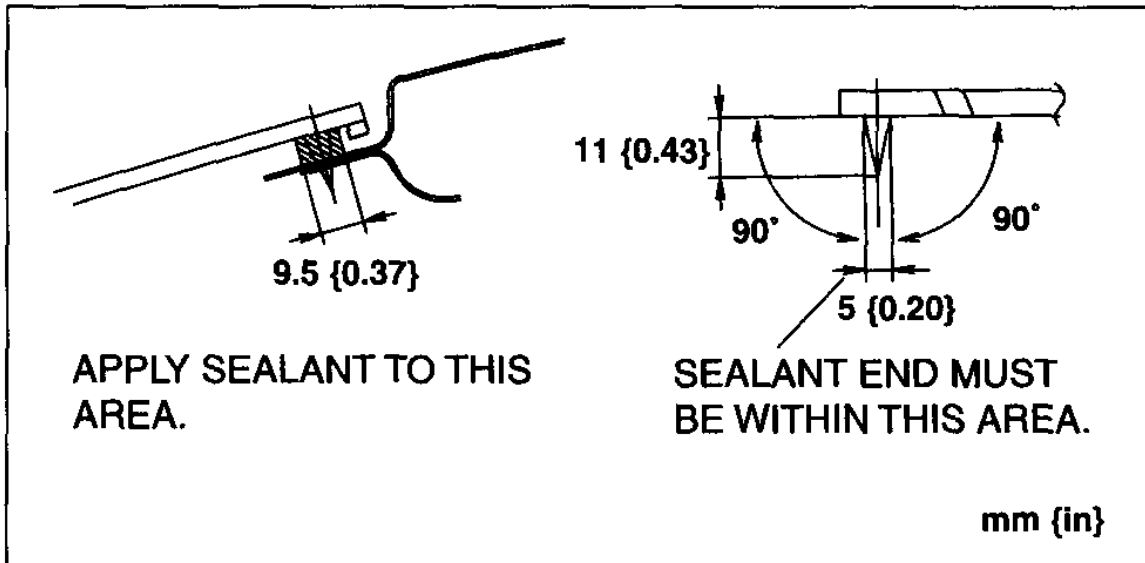
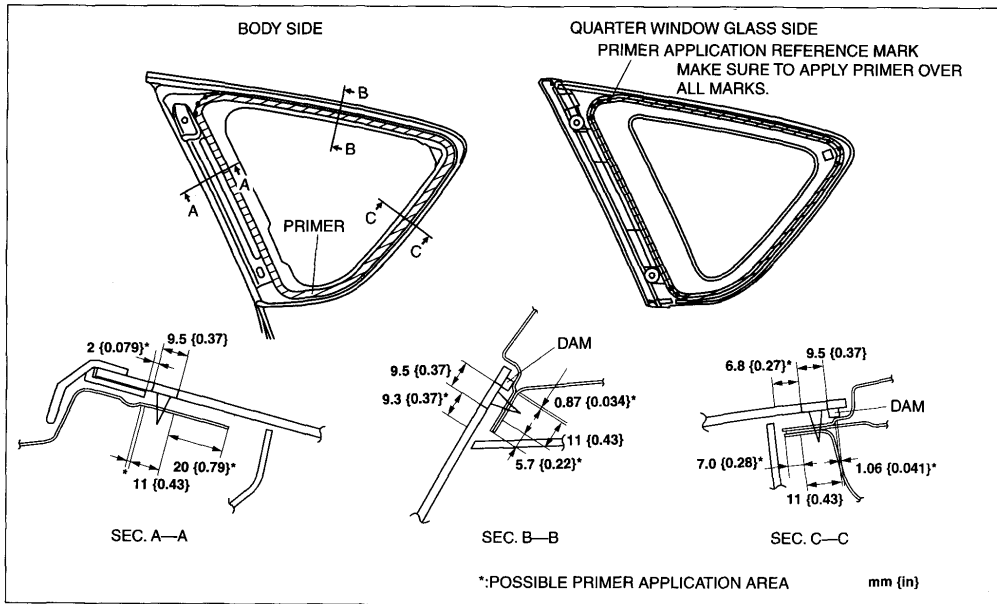

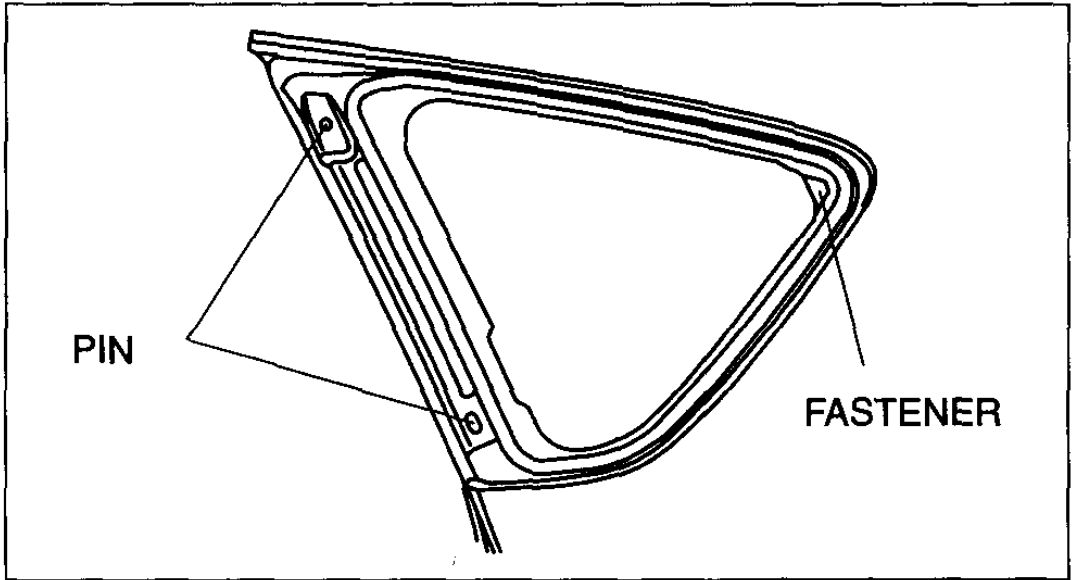

B3E0912W208

All Technical Service Bulletins (itype_100)

- Tsbs
- Body - Rear Quarter Glass Replacement Precaution (0902309, 2009/04/16)

Repair Tips (itype_110)

- Tsbs
- Body - Rear Quarter Glass Replacement Precaution (0902309, 2009/04/16)