

Component Procedures: Flywheel

Table of Contents

1. Parts and Labor (itype_189)
2. Mechanical (including Torque) (itype_28)
3. Flywheel Inspection [LF, L3] (Article 1391457)
4. Dual-Mass Flywheel Inspection [L3 With TC] (Article 1391458)

Component Procedures: Flywheel

Parts and Labor (itype_189)

Parts

Qualifier	Part #	Name	Price	Note
-	L32711500C	Flywheel	351.52	

Labor

Operation	Qualifier Path	Skill	Std Hrs	Wty Hrs
Replace	Flywheel, R&R	B	4.6	0.0

Mechanical (including Torque) (itype_28)

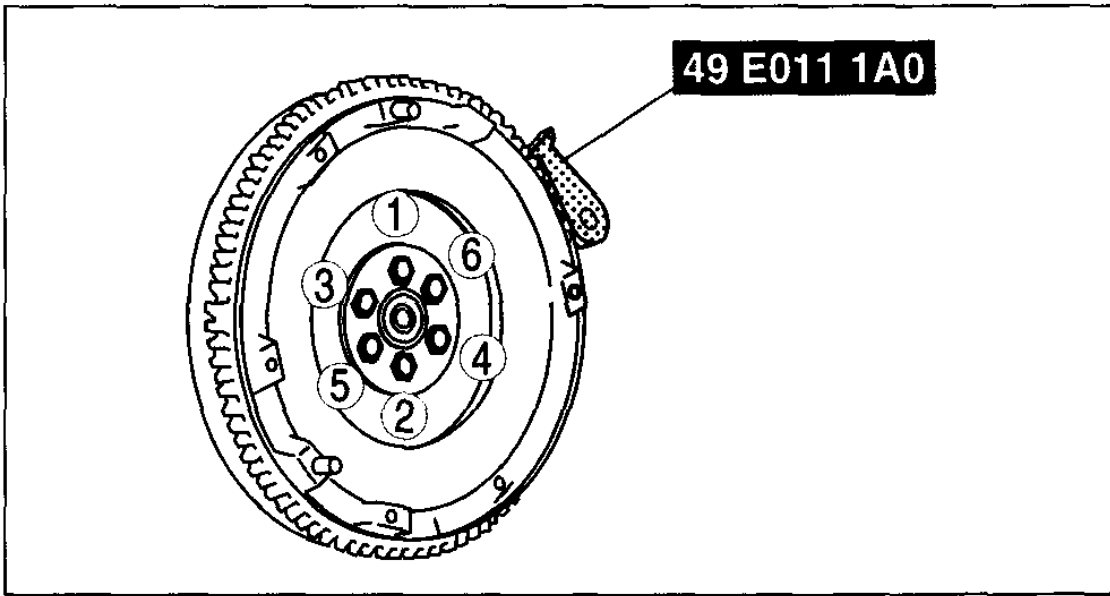

am3uuw000020

Flywheel Inspection [LF, L3] (Article 1391457)

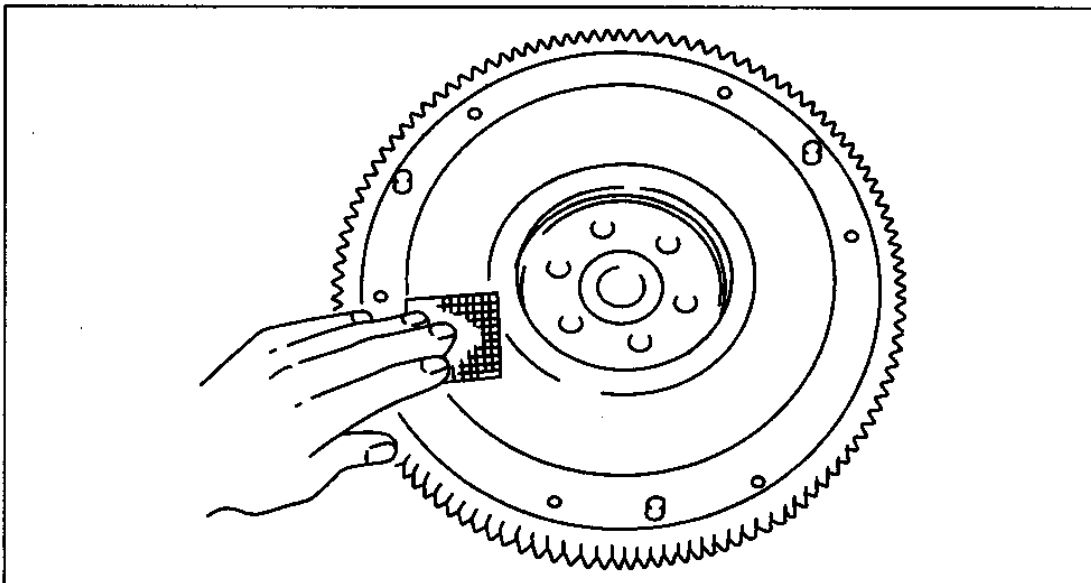

am3uuw000019

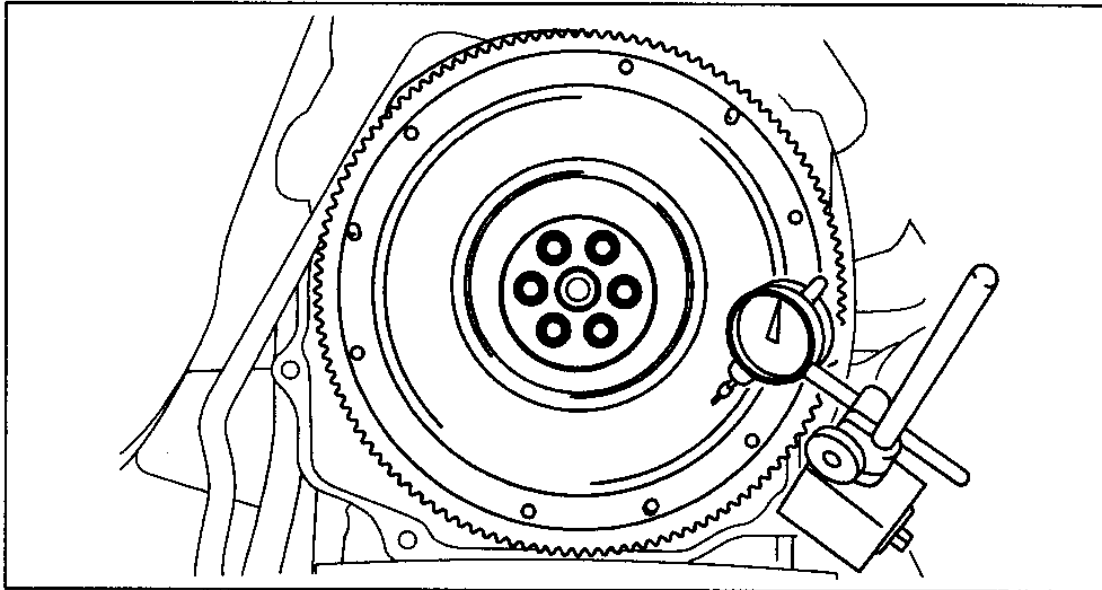

am3uuw0000019

Dual-Mass Flywheel Inspection [L3 With TC] (Article 1391458)

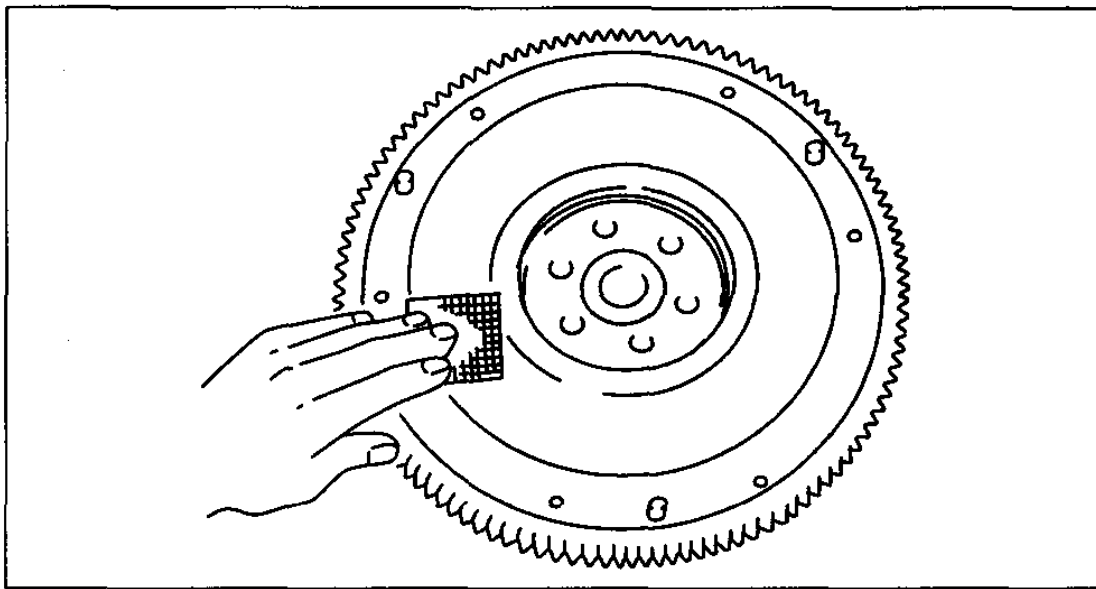

am3zzw0000031

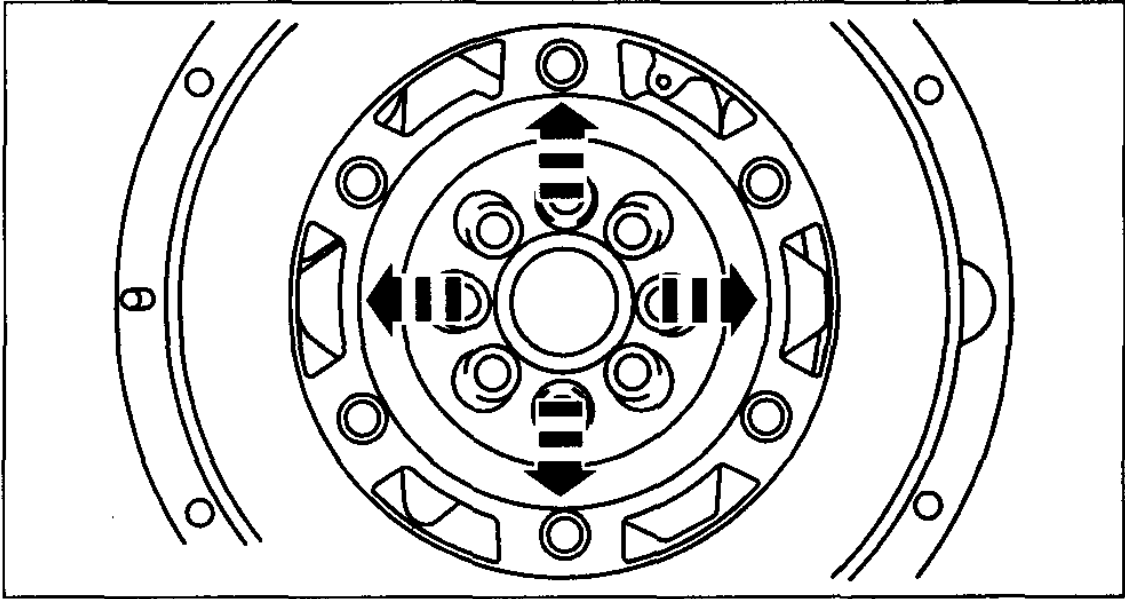

am3zzw0000031

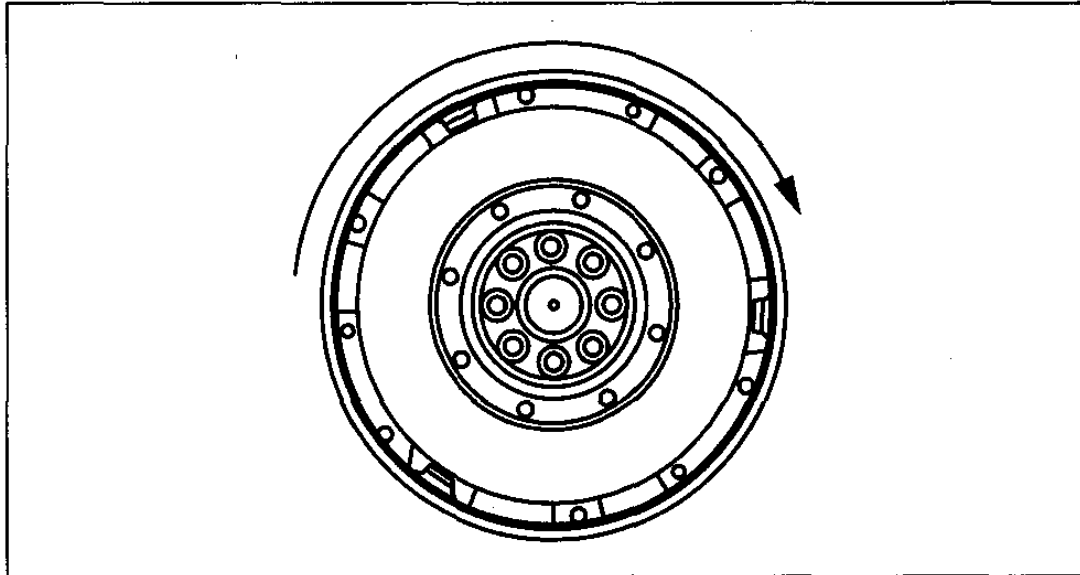

am3zzw0000031

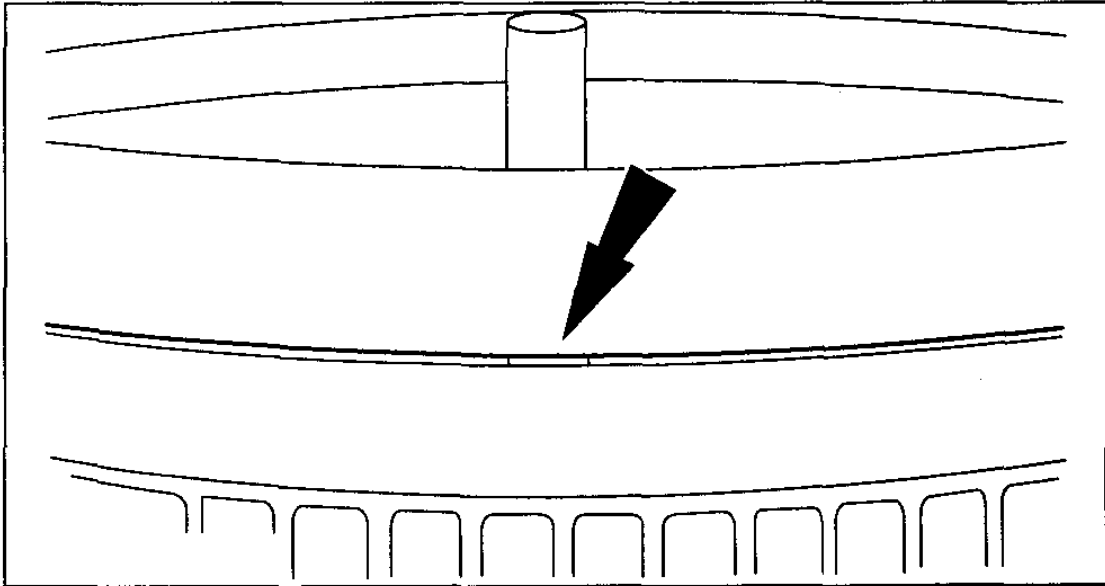

am3zzw0000031

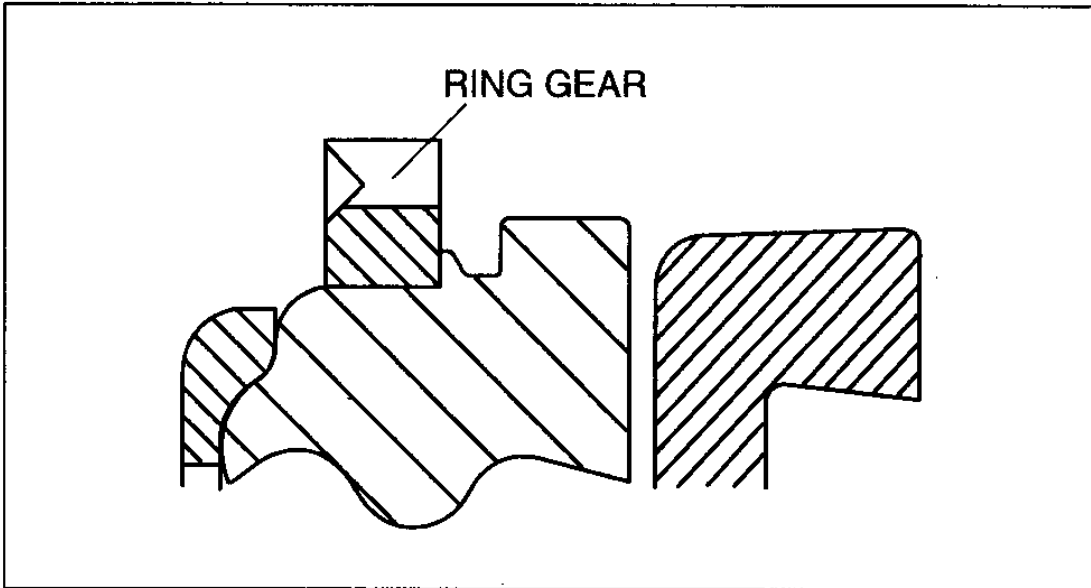

am3zzw0000031

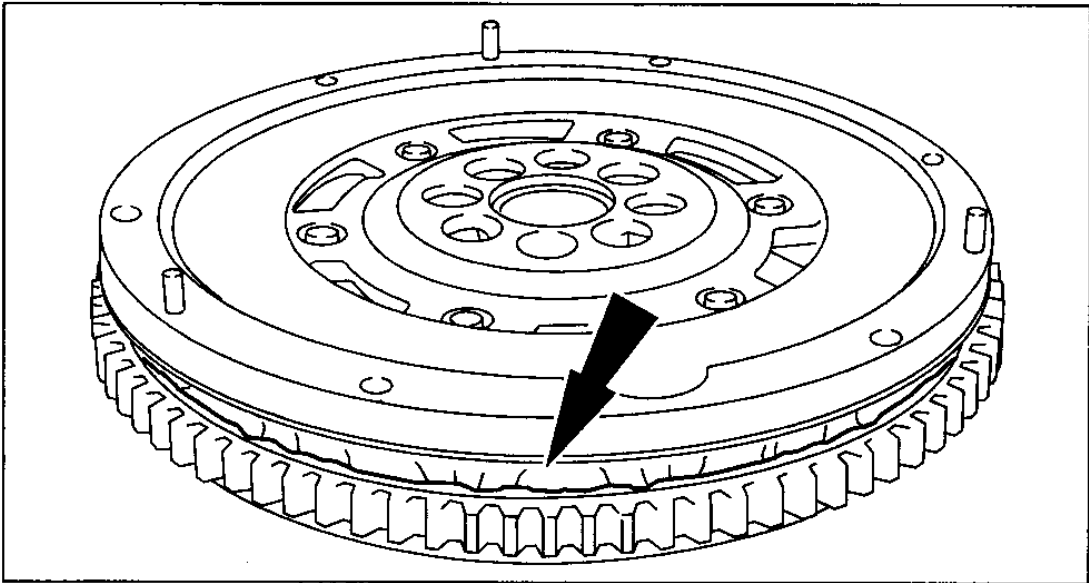

am3zzw0000031

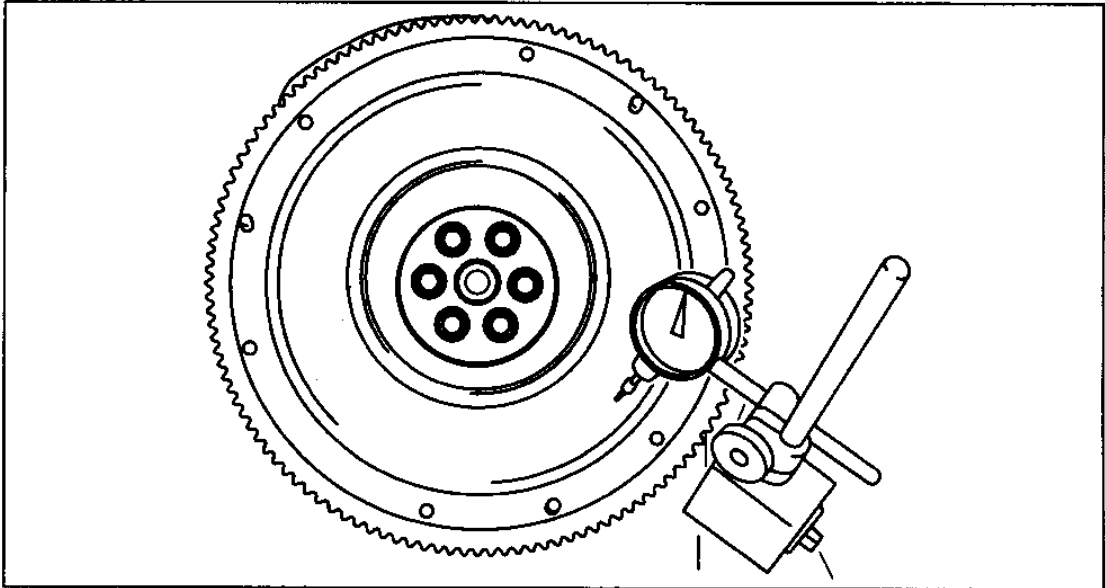

am3zzw0000031

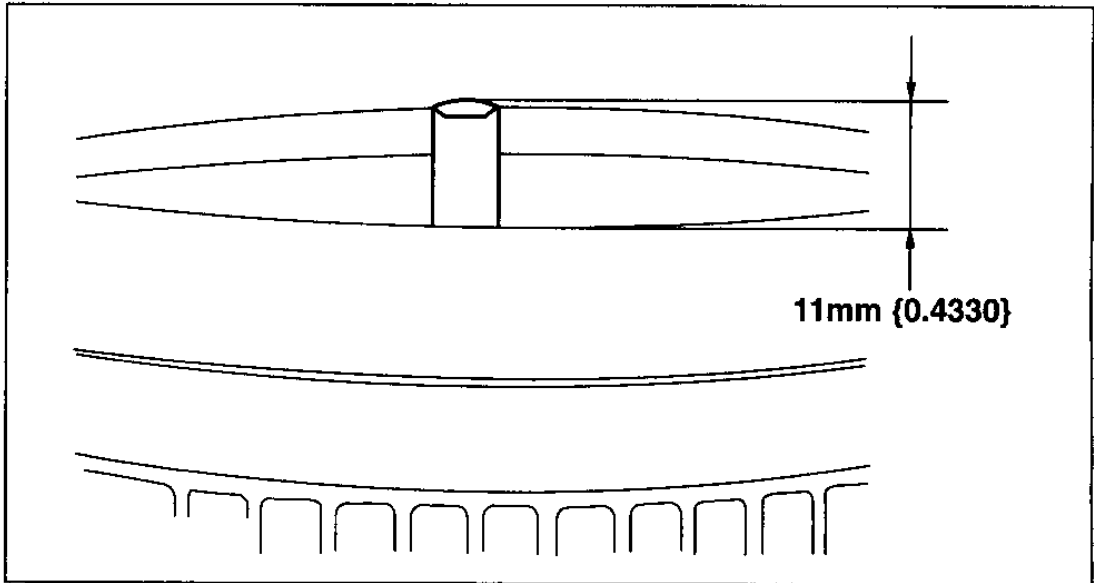

am3zzw0000031

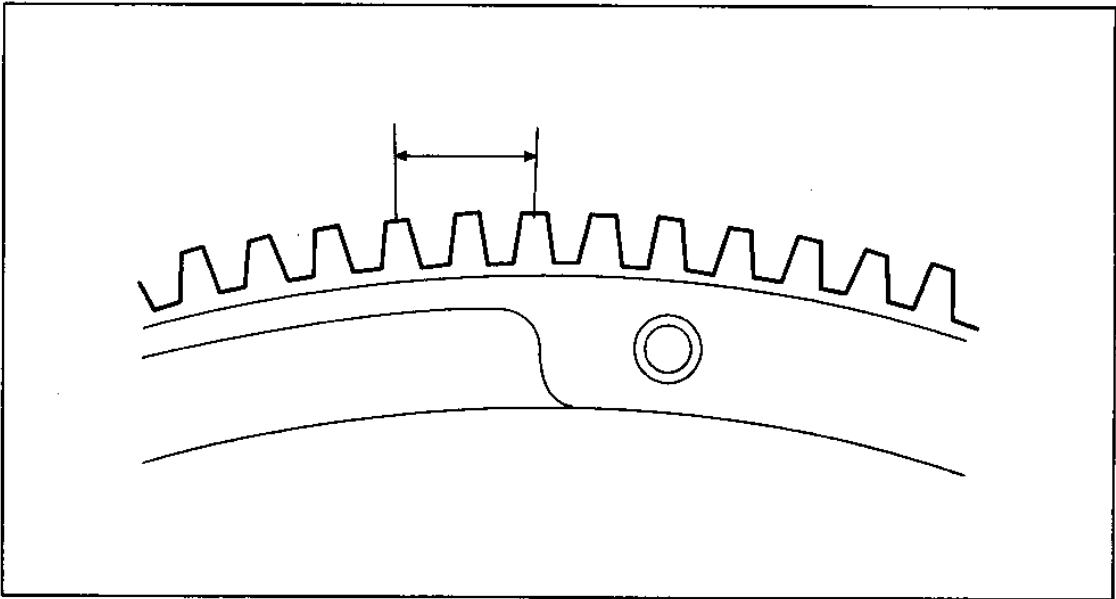

am3uuw0000018