

Component Procedures: Rear Crankshaft Main Bearing Seal

Table of Contents

1. Parts and Labor (itype_189)
2. Rear Oil Seal Replacement (Article 1391386)

Component Procedures: Rear Crankshaft Main Bearing Seal

Parts and Labor (itype_189)

Labor

Operation	Qualifier Path	Skill	Std Hrs	Wty Hrs
Replace	Rear Main Seal > Auto Trans	B	6.4	0.0
Replace	Rear Main Seal > Manual Trans	B	5.1	0.0

Rear Oil Seal Replacement (Article 1391386)

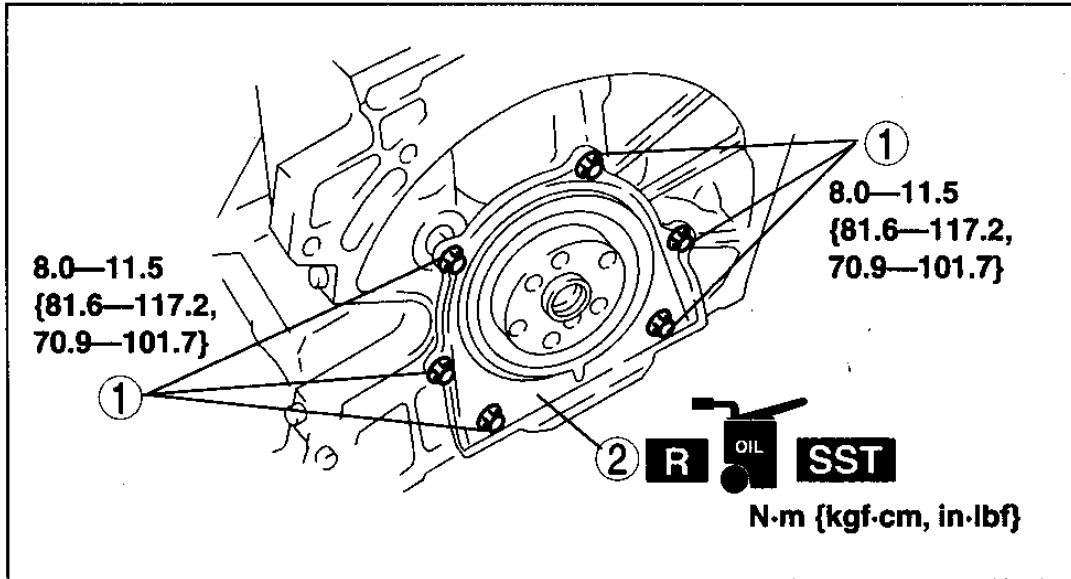

am3uuw0000112

1	Bolt
2	Rear oil seal (See Rear Oil Seal Installation Note.)

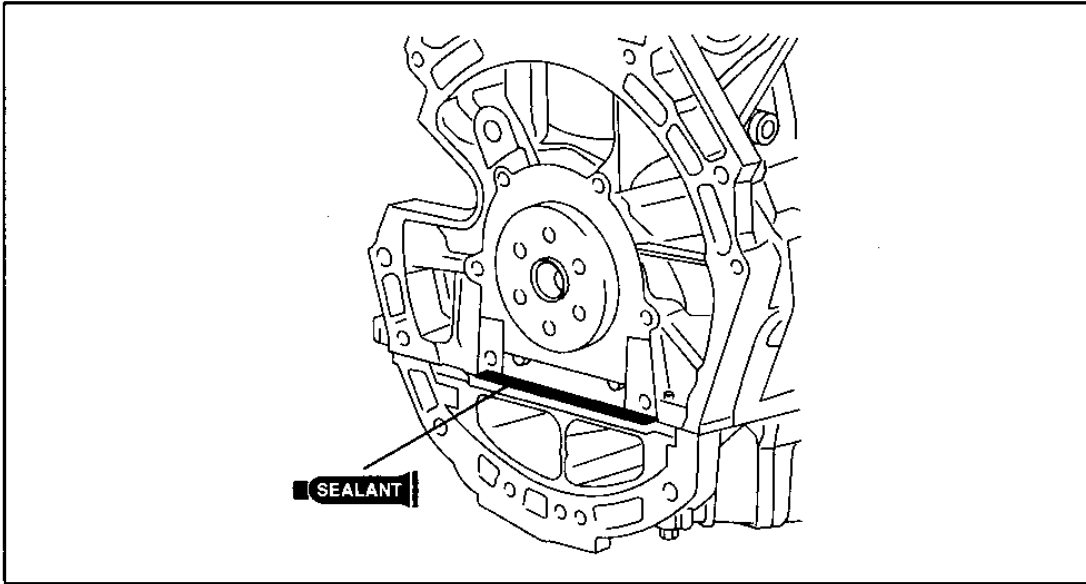

am3uuw0000112

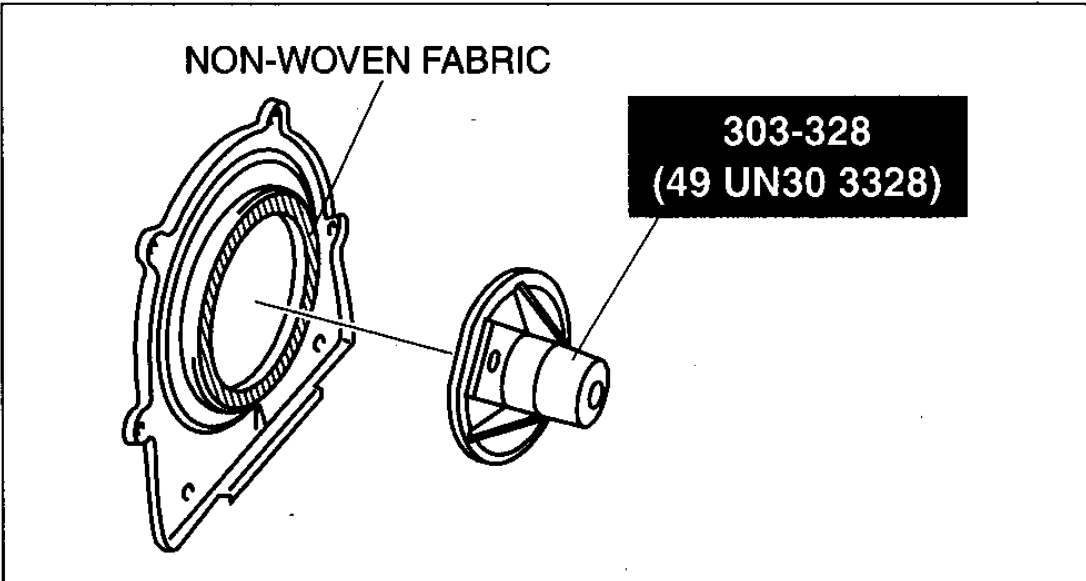

am3uuw0000113

BACK SIDE OF REAR OIL SEAL

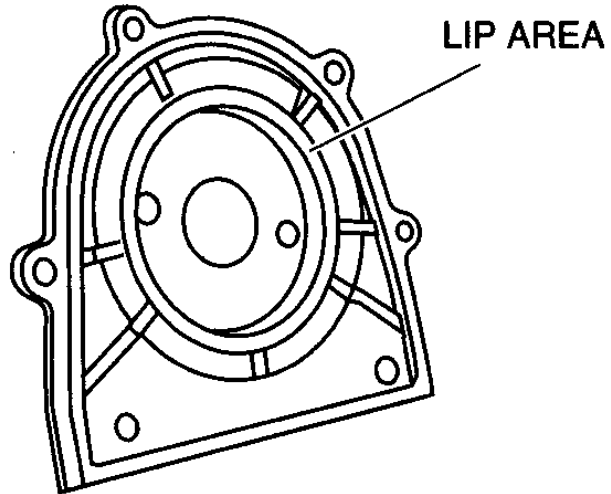

am3uuw0000113

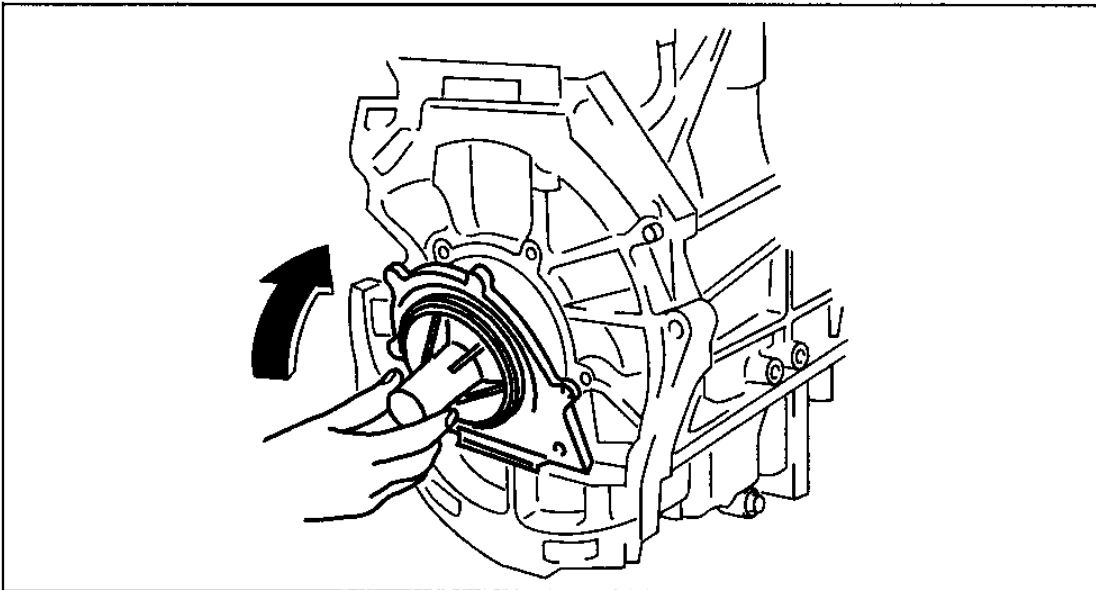

am3uuw0000113

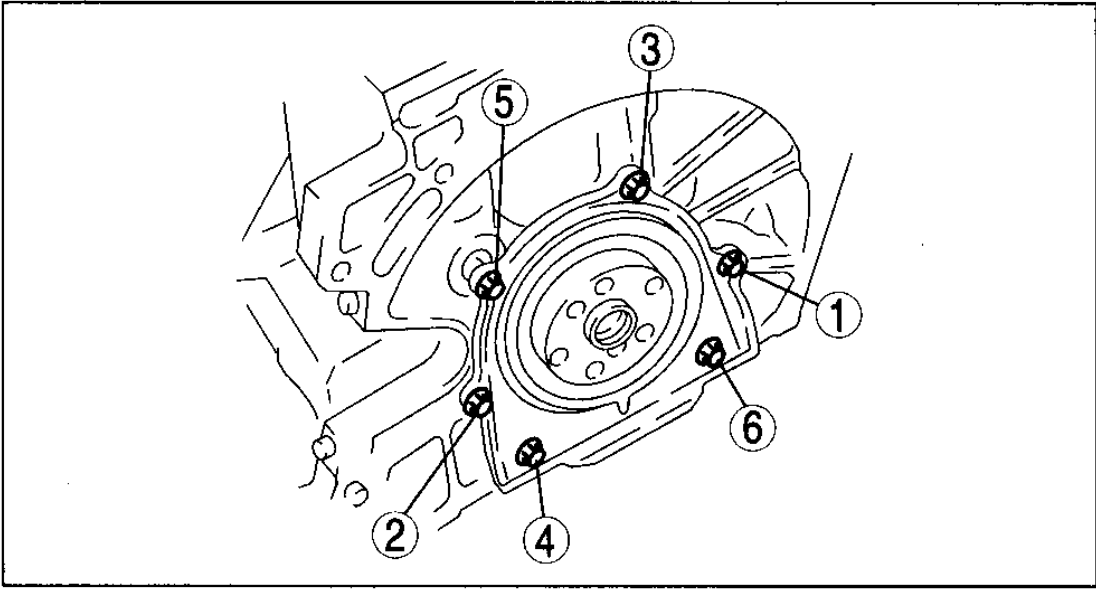

am3uuw0000112