

Component Procedures: Muffler

Table of Contents

1. Parts and Labor (itype_189)
2. Presilencer, Main Silencer Replacement (LF, L3) (Article 1448509)

Component Procedures: Muffler

Parts and Labor (itype_189)

Labor

Operation	Qualifier Path	Skill	Std Hrs	Wty Hrs
Replace	Muffler, R&R	B	0.9	0.7

Presilencer, Main Silencer Replacement (LF, L3) (Article 1448509)

Cut Location

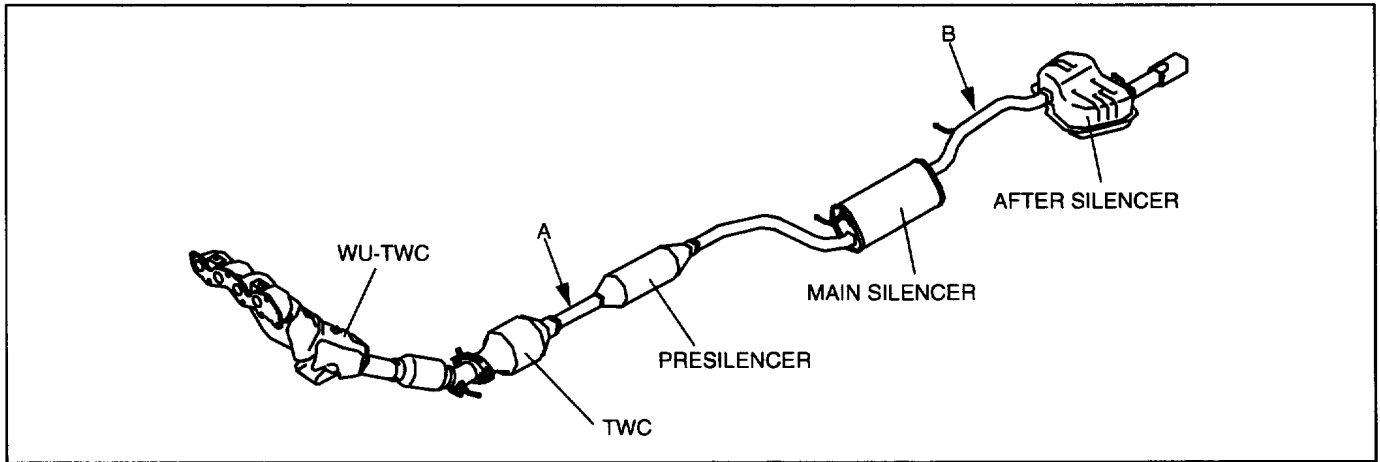

e3u115zw6307

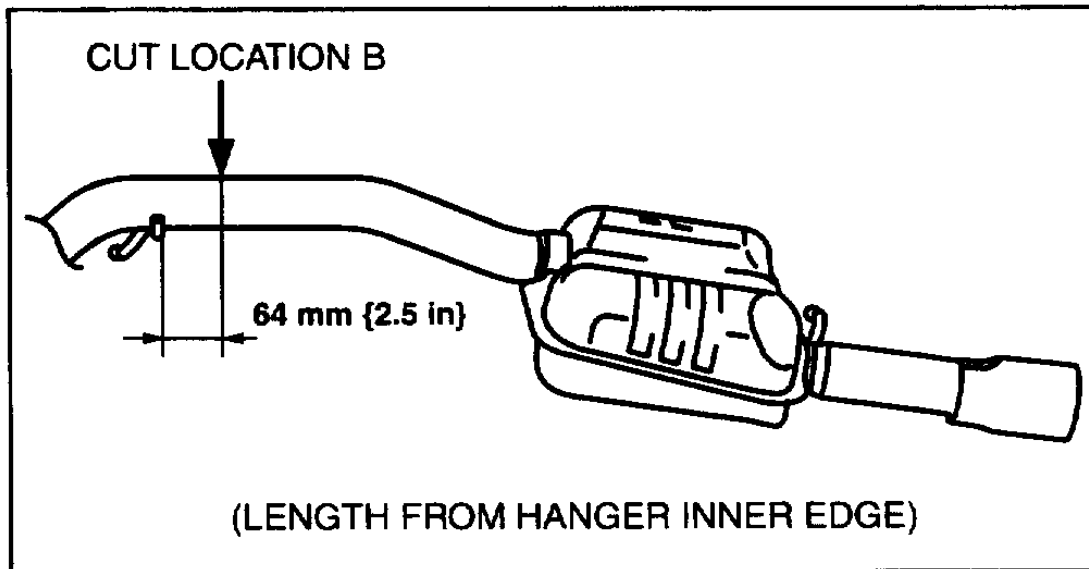

e3u115zw6302

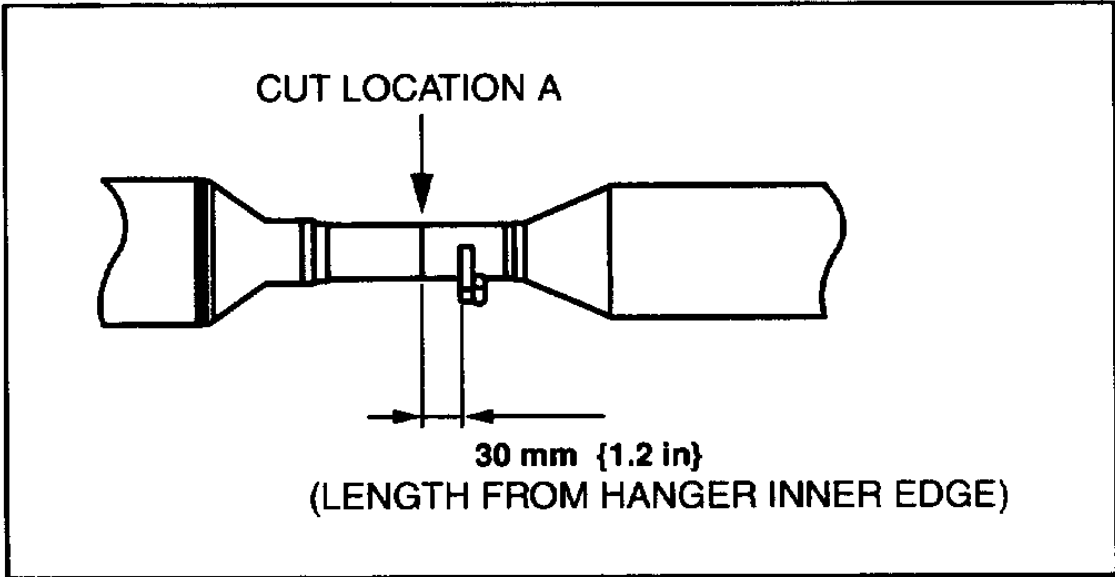

B3E115BW9010

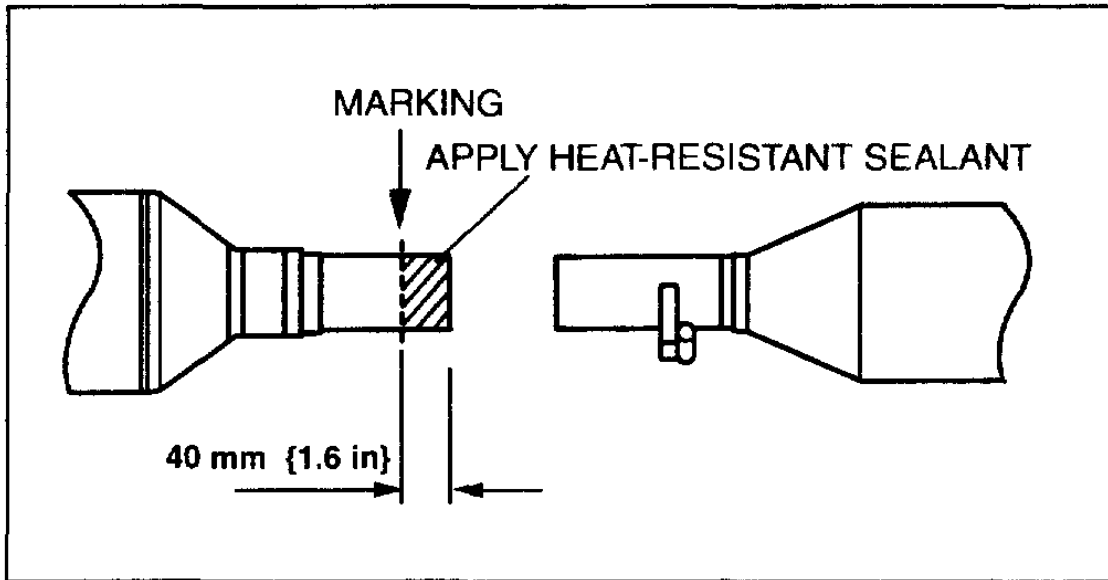

B3E115BW9011

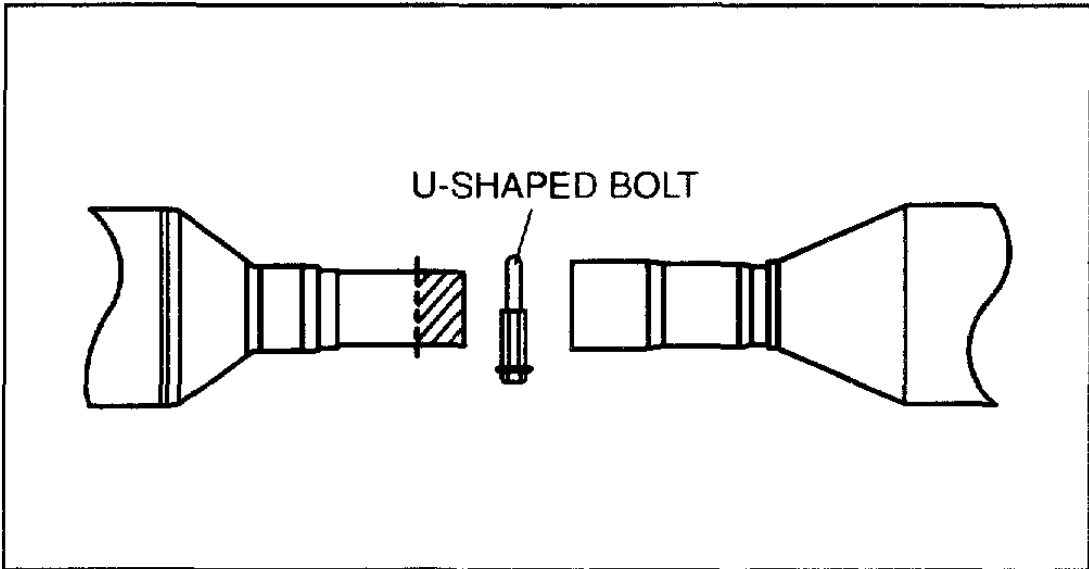

B3E115BW9018

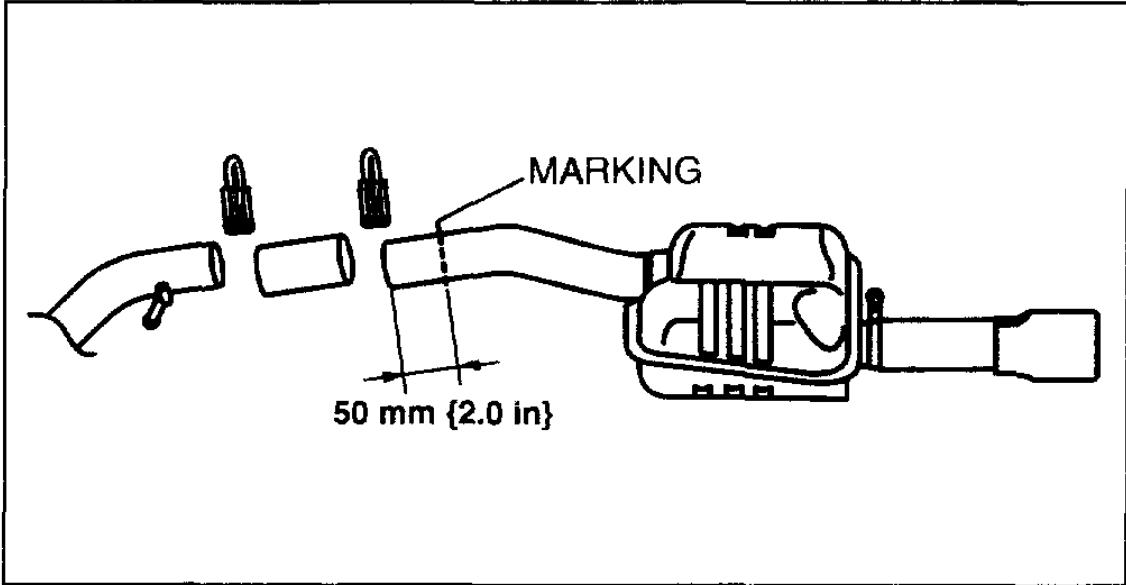

e3u115zw6303

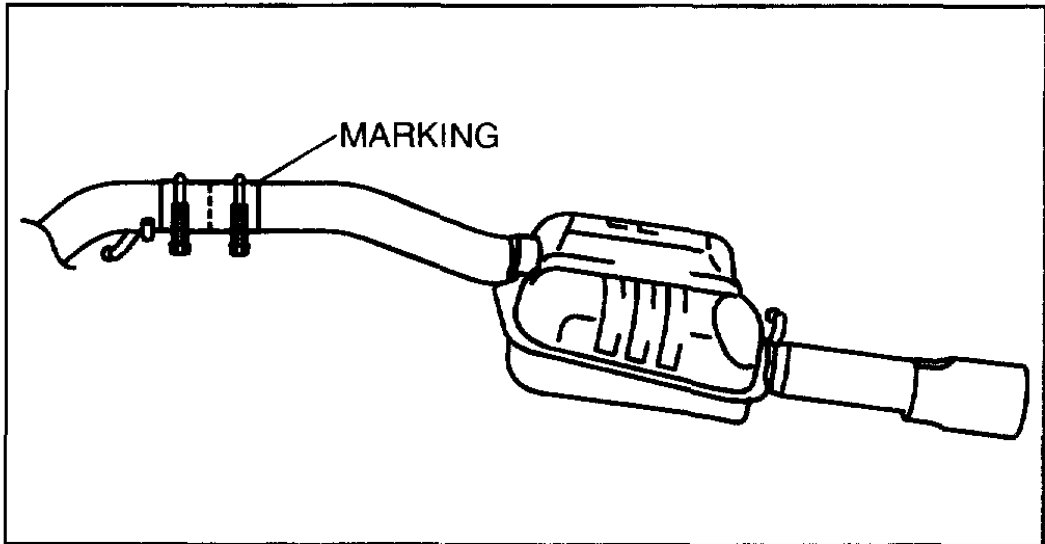

e3u115zw6304

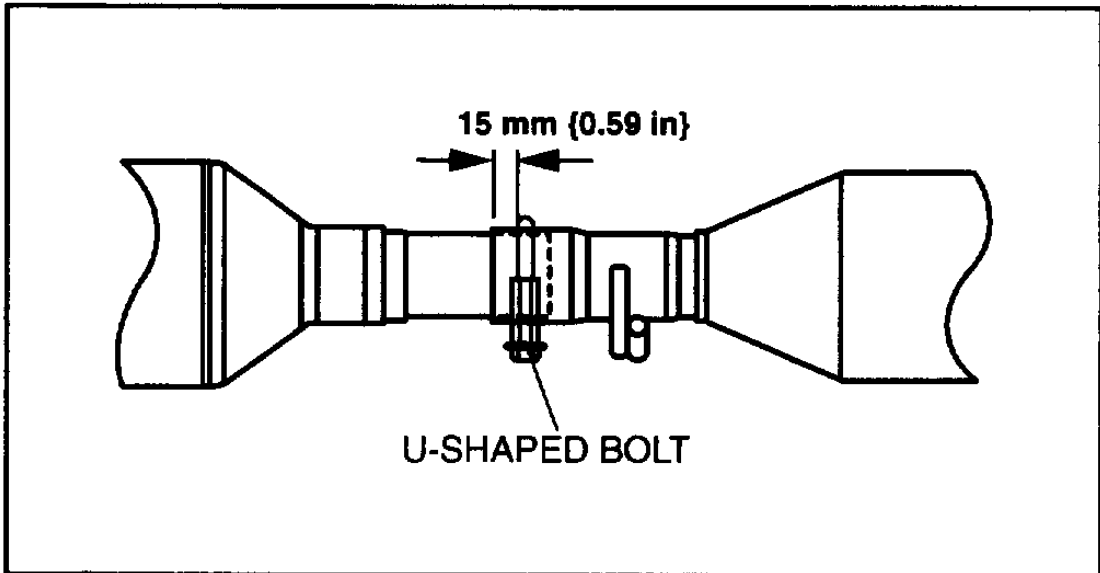

B3E115BW9014

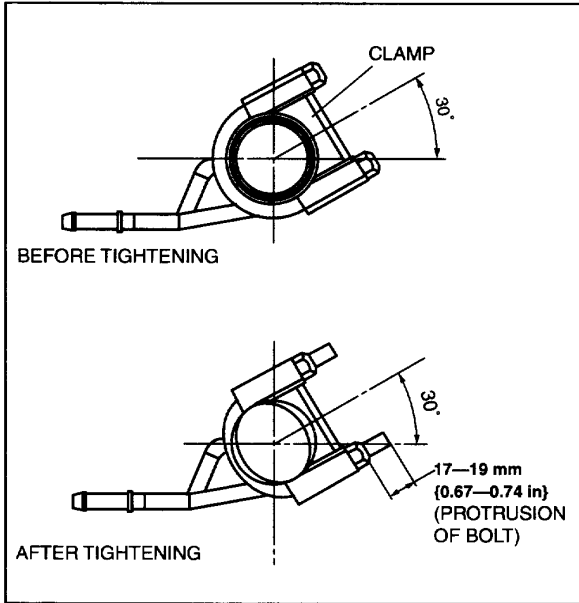

e3u115zw6306

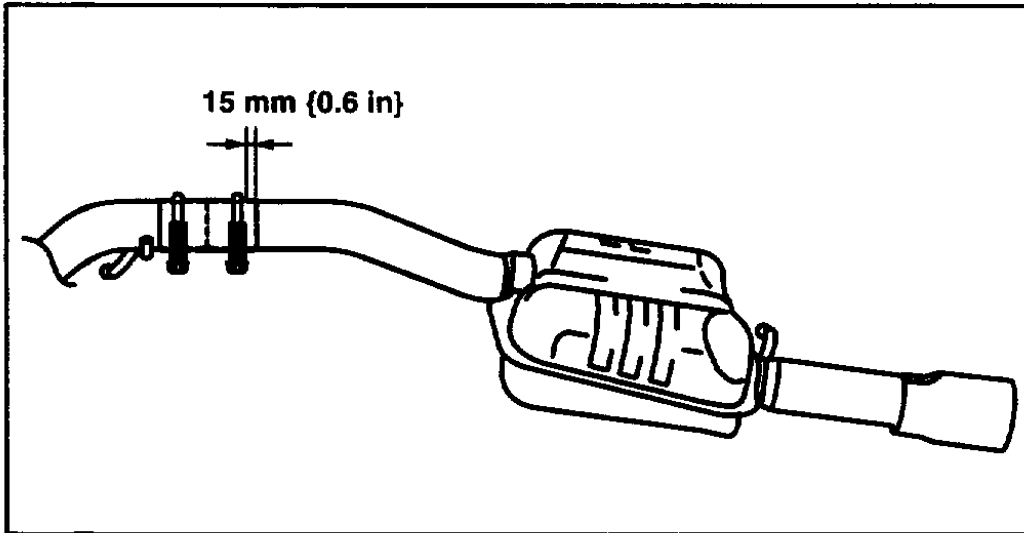

e3u115zw6305

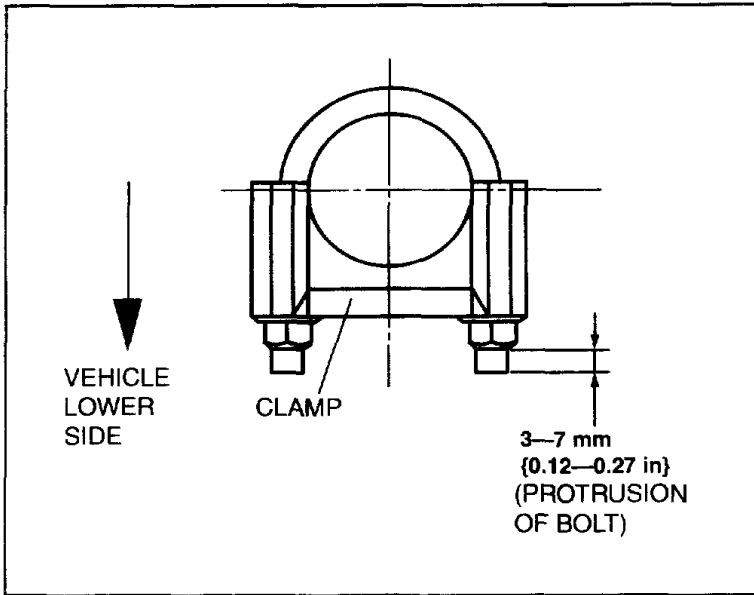

e3u115zw6308

Cut Location

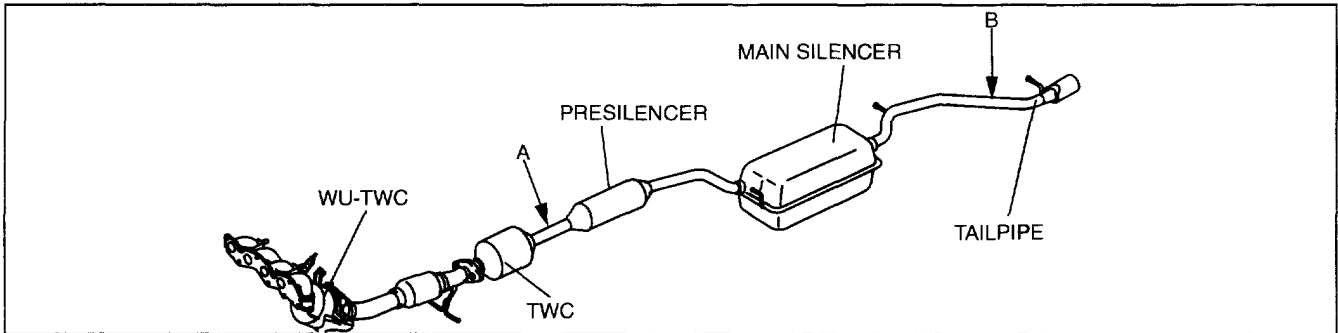

B3E115BW9001

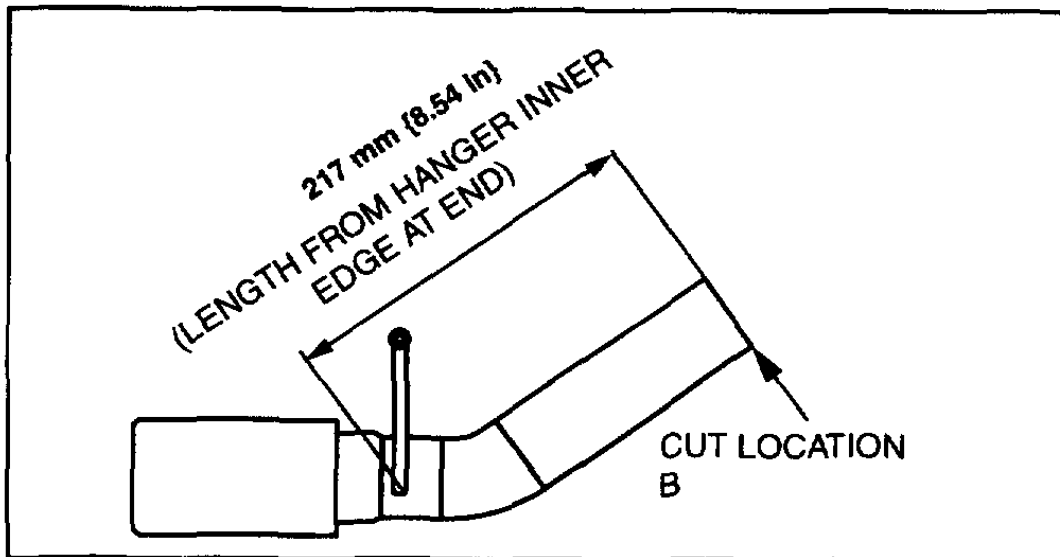

B3E115BW9009

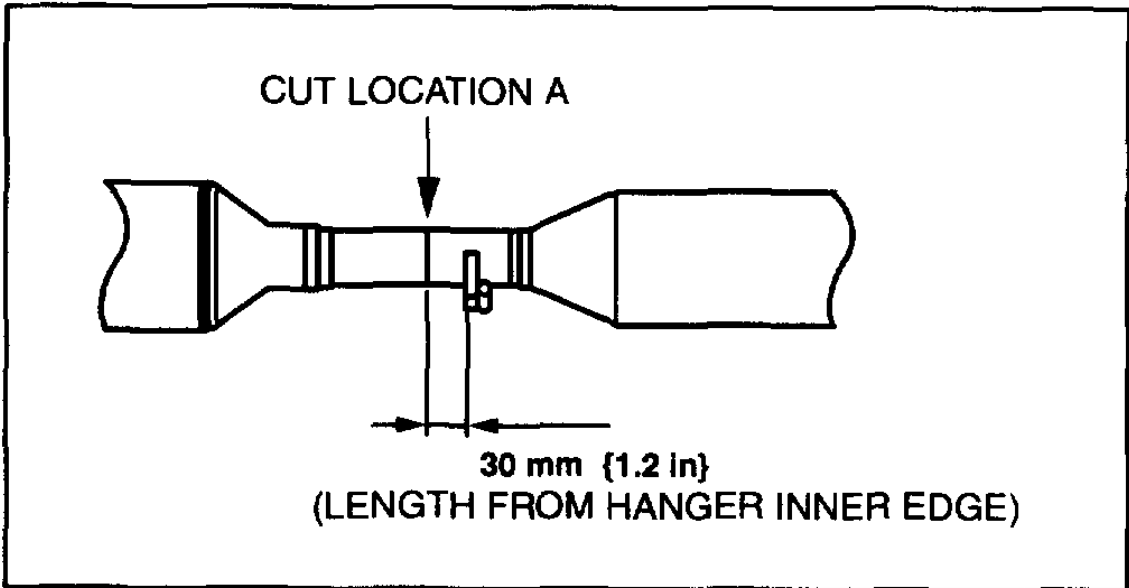

B3E115BW9010

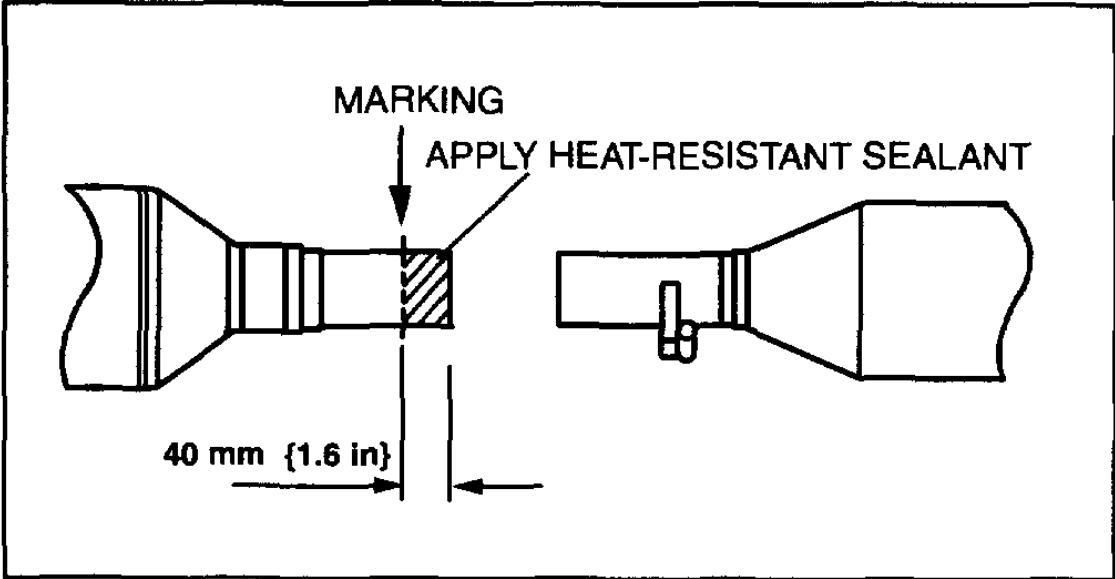

B3E115BW9011

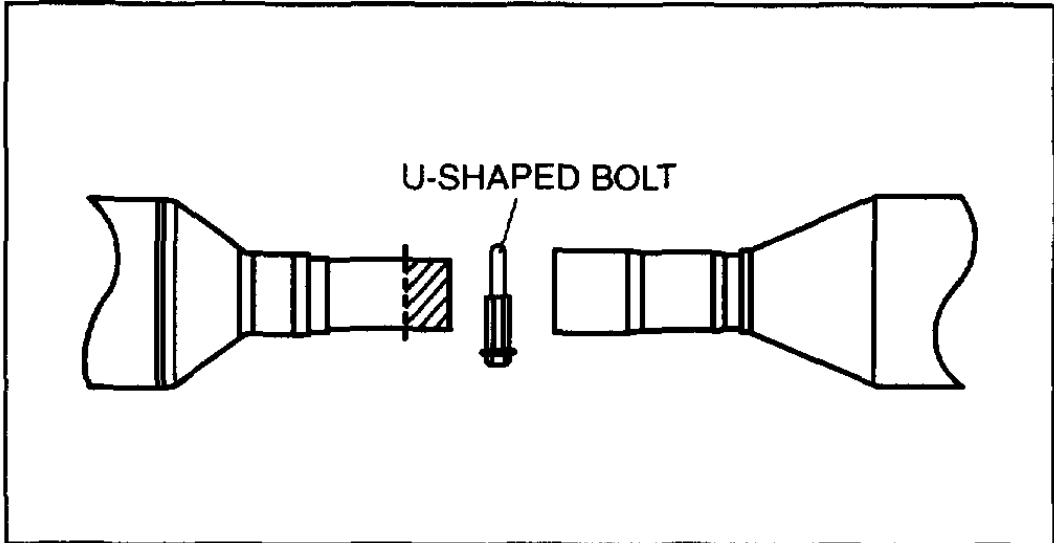

B3E115BW9018

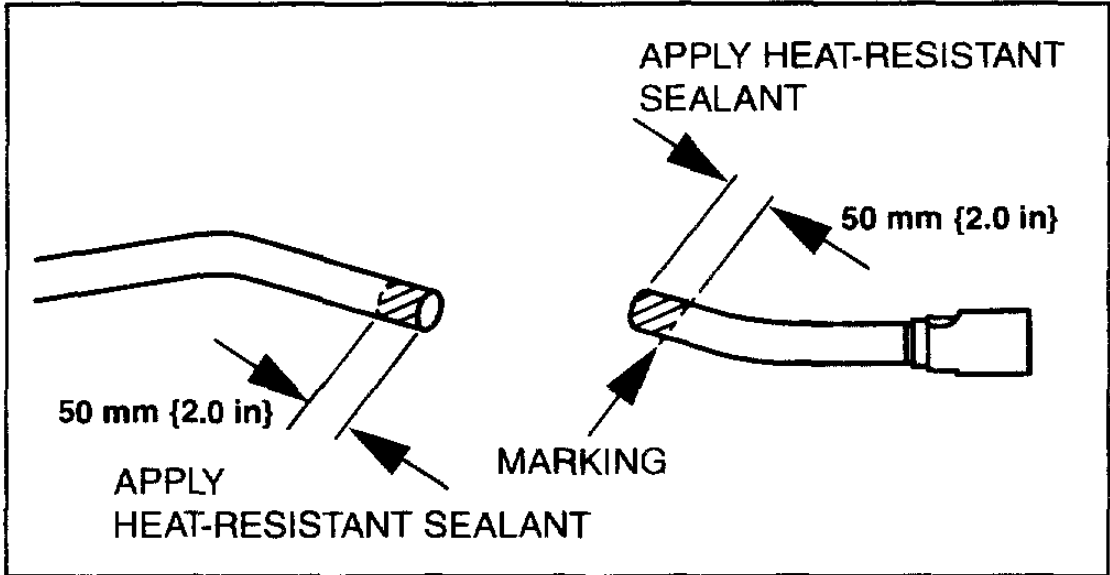

B3E115BW9012

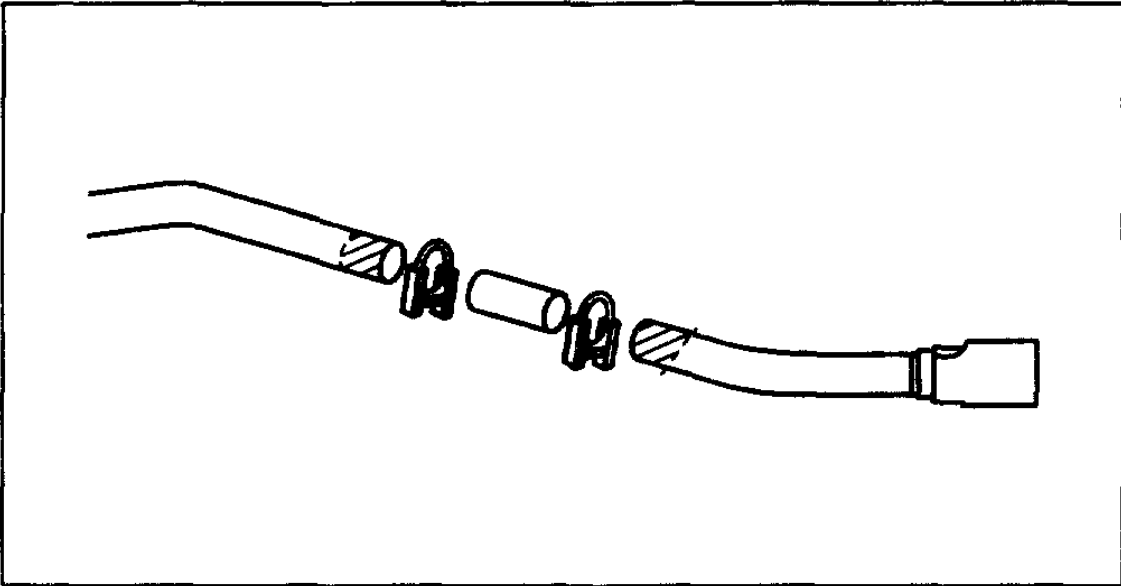

B3E115BW9019

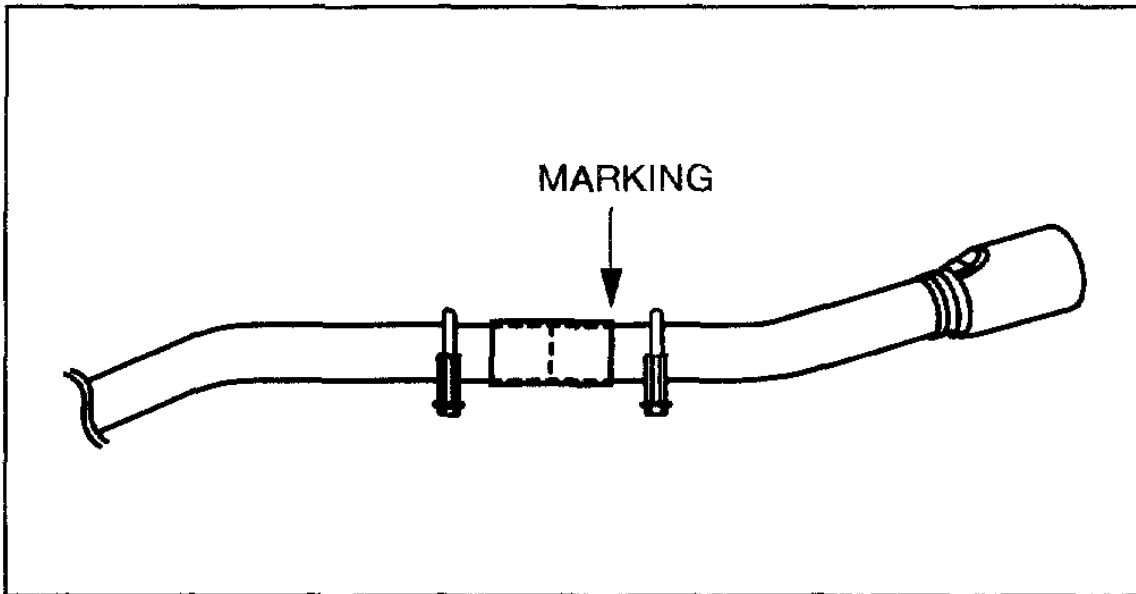

B3E115BW9013

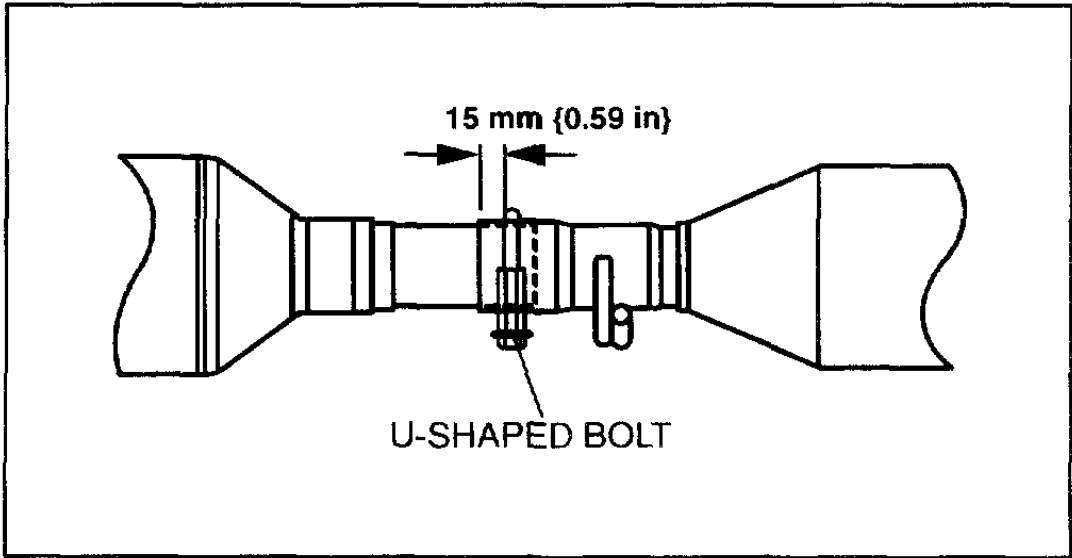

B3E115BW9014

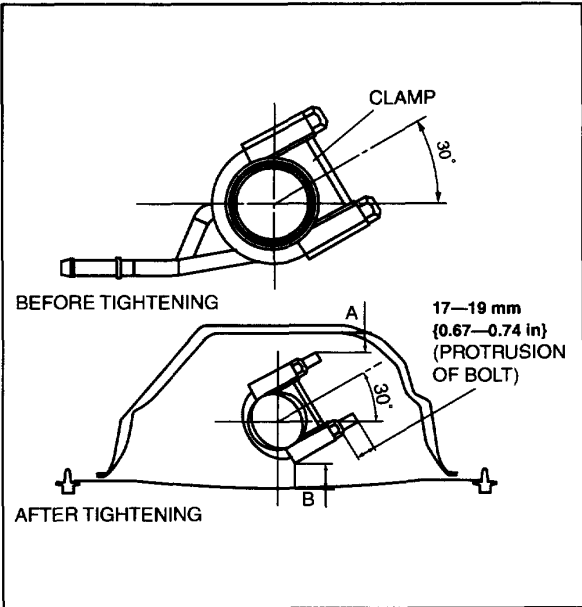

B3E115BW9008

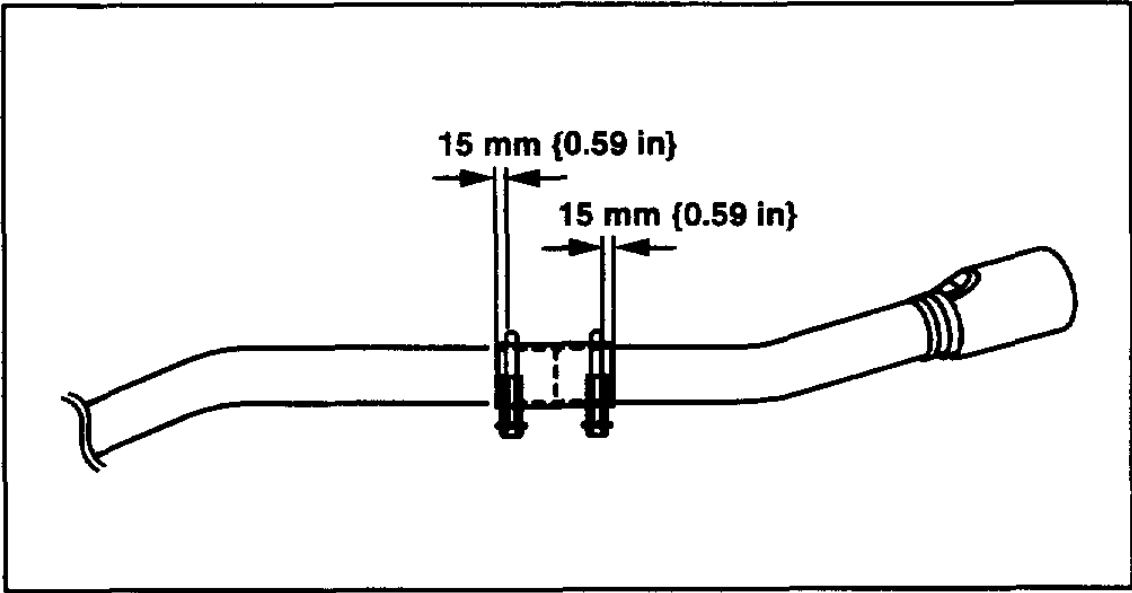

B3E115BW9015

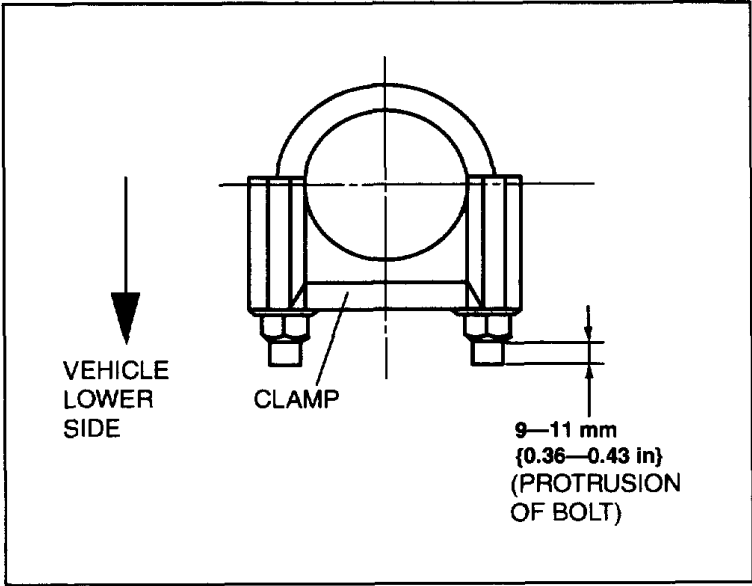

B3E115BW9016