

Component Procedures: Collision Avoidance and Parking Assist Systems

Table of Contents

1. Parts and Labor (itype_189)
2. Autonomous Emergency Braking (AEB) System - Description and Operation (Article 45215)
3. Blind-Spot Collision Warning (BCW) System - Service Tips (Article 42600)
4. Blind-Spot Radar - Description and Operation (Article 44694)
5. Parking Distance Warning - Description and Operation (Article 44665)
6. Parking Distance Warning Switch - Schematic Diagrams (Article 44670)
7. Autonomous Emergency Braking (AEB) System - Schematic Diagrams (Article 45219)
8. Blind-Spot Collision Warning (BCW) System - Schematic Diagrams (Article 42599)
9. Blind Spot Information System Circuit (AD) (Article 12348)
10. Blind Spot Information System Circuit (ADA) (Article 12283)
11. Lane Keeping Assist Circuit (Article 12451)
12. Parking Assistant Circuit (Article 12305)
13. Autonomous Emergency Braking (AEB) System - Components and Components Location (Article 45217)
14. Blind-Spot Radar - Components and Components Location (Article 44693)
15. Blind-Spot Radar System - Components and Components Location (Article 44700)
16. Component Location and Function (Parking Guide System) (Article 39317)
17. Component Location and Function (SBW Control Unit) (Article 39415)
18. Parking Distance Warning - Components and Components Location (Article 44664)
19. Parking Distance Warning Switch - Components and Components Location (Article 44668)
20. Blind-Spot Radar - Repair Procedures (Article 44695)
21. Parking Distance Warning Switch - Repair Procedures (Article 44671)
22. Blind-Spot Radar - Specifications (Article 44692)
23. Parking Distance Warning - Specifications (Article 44663)
24. All New Technical Service Bulletins (itype_432)
25. All Technical Service Bulletins (itype_100)
26. Blind-Spot Collision Warning (BCW) System - Service Tips (Article 42601)
27. Erratic Operation (itype_132)
28. Poor performance (itype_162)
29. OEM Policies and Procedures (itype_120)

Component Procedures: Collision Avoidance and Parking Assist Systems

Parts and Labor (itype_189)

Parts

Qualifier	Part #	Name	Price	Note
Parking Aid > Camera	99240F2000PR3	With Smart Key	514.50	

Labor

Operation	Qualifier Path	Skill	Std Hrs	Wty Hrs
Remove & Replace	Parking Aid > Sensor, R&R > Front > All	B	1.8	0.0
Remove & Replace	Parking Aid > Sensor, R&R > Front > One	B	1.6	0.0
Remove & Replace	Parking Aid > Sensor, R&R > Rear > All	B	2.1	0.0
Remove & Replace	Parking Aid > Sensor, R&R > Rear > One	B	1.9	0.0

Autonomous Emergency Braking (AEB) System - Description and Operation (Article 45215)

- Description
- AEB system is designed to help avoid a potential collision or reduce its impact when drivers applies inadequate, delayed or no brakes at all to avoid a collision.
- The system detects the risk factors on the road by using the frontal impact sensor and warn the driver and activate the emergency brake to prevent collision or reduce collision speed.
- Detect preceding vehicles (pedestrians) and analyze the data (CAN comm.) by using the radar sensor of the Smart Cruise Control System (SCC) and the camera sensor of Lane Departure Warning System (LDWS).
- Confirm the object to be protected by AEB system (vehicles and pedestrians) by using the analyzed data.
- Calculate the speed reduction depending on the speed, distance, existence or nonexistence of preceding vehicle.
- Report the "required speed reduction" to Vehicle Dynamics Control (VDC) (CAN Comm.)
- VDC performs automatic control after calculating the required torque to achieve "required speed reduction" (CAN Comm.).
- Operation

► Over view of AEB Activation

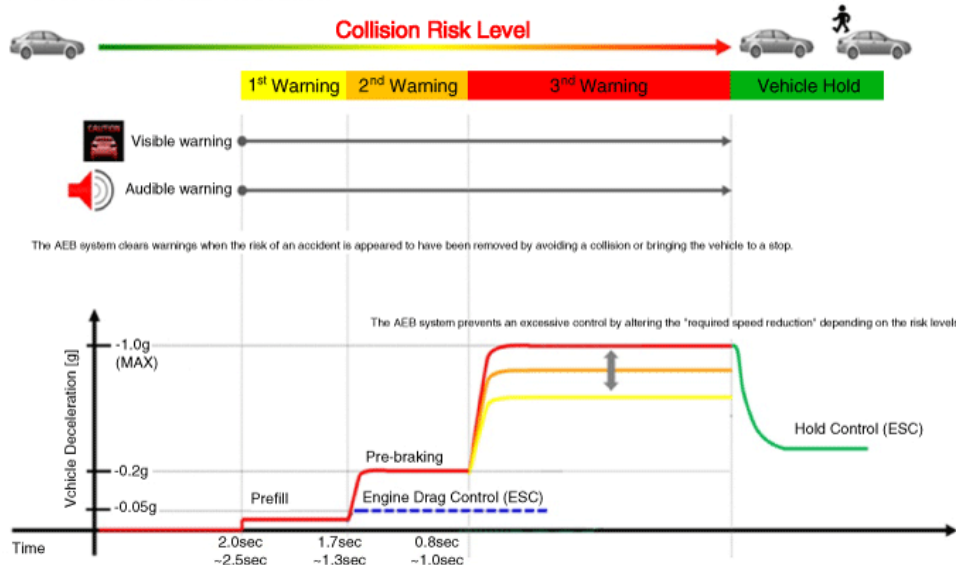

- Step 1 : Issue a visual (display) and vocal alarm when a danger is detected.
 - Step 2 : Reduce engine torque and activates AEB when there is a high chance of collision.
 - Step 3 : Activate emergency brake when a collision is imminent.
 - After stopping the vehicle : Maintain the braking control for a certain time and then release it.
- Braking power is adjusted depending on the risk levels of collision, but it is released immediately when it detects the driver's action to avoid a collision. When it exceeded the maximum operation speed. When it detected driver's action to avoid a collision such as sudden steering changes. When the shift lever is in R or

P When you pressed the accelerator pedal half way.



Information

- Braking power is adjusted depending on the risk levels of collision, but it is released immediately when it detects the driver's action to avoid a collision.
- When it exceeded the maximum operation speed.
- When it detected driver's action to avoid a collision such as sudden steering changes.
- When the shift lever is in R or P
- When you pressed the accelerator pedal half way.

When you drive at 80km/h or faster, the system does not go to step 3 of emergency braking. - Full auto braking is not available. While driving at 80km/h or slower on a straight or slightly curved road, the system performs three steps after issuing a warning. - But a collision may occur at 30km/h or faster depending on the road conditions. While driving at 80km/h or slower on a straight or slightly curved road, after a visual and vocal warning, AEB is activated to reduce the vehicle speed. At 80km/h or faster, it's impossible to avoid a collision. Offset should be less than 50%. AEB does not work on the vehicles backing up or resisting. At 70km/h or faster, it does not respond to pedestrians.



- When you drive at 80km/h or faster, the system does not go to step 3 of emergency braking. - Full auto braking is not available.
 - While driving at 80km/h or slower on a straight or slightly curved road, the system performs three steps after issuing a warning. - But a collision may occur at 30km/h or faster depending on the road conditions.
 - While driving at 80km/h or slower on a straight or slightly curved road, after a visual and vocal warning, AEB is activated to reduce the vehicle speed.
 - At 80km/h or faster, it's impossible to avoid a collision. Offset should be less than 50%.
 - AEB does not work on the vehicles backing up or resisting.
 - At 70km/h or faster, it does not respond to pedestrians.
- Offset : Rate of non-overlapping on the line between the front driving car and my car Offset 0% : Offset 100%
:
- Offset 0% :

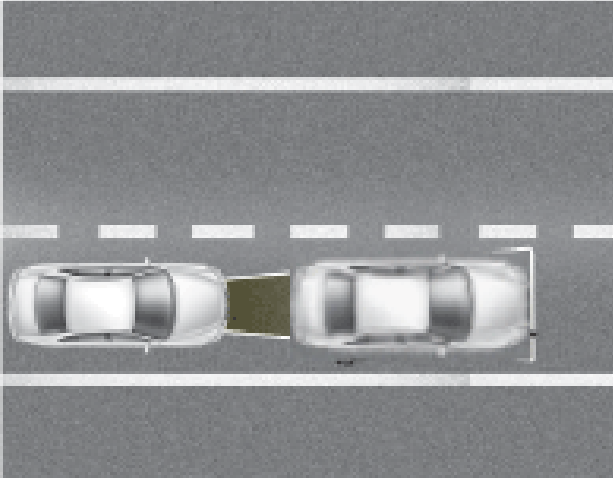

- Offset 100% :

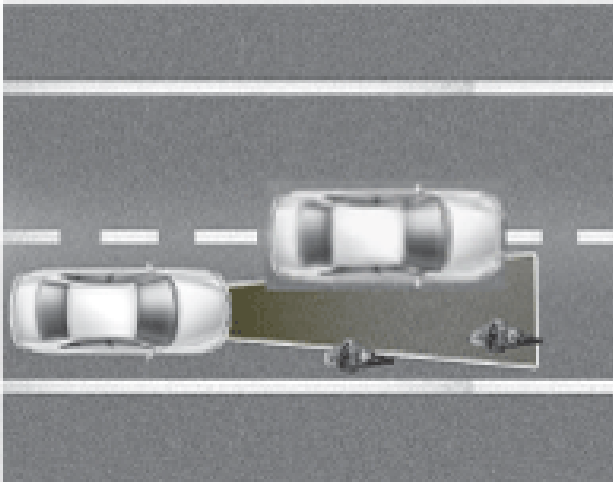

Blind-Spot Collision Warning (BCW) System - Service Tips (Article 42600)

Blind-Spot Collision Warning (BCW) System	Service Tips (1)
<p>Circuit Description</p> <p>Blind Spot Collision Warning System operates BCW (Blind Spot Collision Warning), LCA (Lane Change Assist) functions by providing an alert when a vehicle has entered a blind spot to the rear or side of the vehicle.</p> <p>Blind Spot Collision Warning System assists drivers by providing information (Visual, auditory) measuring the distance and speed of a rear vehicle using two radars installed on the left and right backside of vehicle.</p> <p>■ Rear And Side Warning Radar (BCW & LCA)</p> <p>BCW radar is Phase Mono-Pulse type of FMCW(Frequency Modulation Continuous Wave). ECU and sensors are integrated module.</p> <p>1. BCW & LCA control sequence</p> <ol style="list-style-type: none"> 1) Driver controls BCW switch. (ON / OFF) 2) BCW & LCA sensor detects rear and side of the vehicle. <ul style="list-style-type: none"> - Calculates position and velocity of rear vehicle using current vehicle's speed signal and yaw sensor. (Rear vehicle speed, distance acceleration/ deceleration, and current road curvature) 3) Alert algorithm <ul style="list-style-type: none"> - Check the alert entry conditions using current vehicle's speed signal and road curvature. - When BCW or LCA warning condition is satisfied, outputs alert. <p>2. Activation conditions of sensors</p> <ol style="list-style-type: none"> 1) BCW Switch : Switch ON (LED illuminates) 2) Speed : Faster than 30km/h. 3) Change of curvature : Longer than 170m. <p>3. Deactivation conditions of sensors.</p> <ol style="list-style-type: none"> 1) BCW Switch : Switch OFF. (LED illuminates) 2) Speed : Slower than 30km/h. 3) Change of curvature : Shorter than 150m. 4) Overtaking speed faster than 15km/h. 	<p>4. Prohibition conditions of BCW System</p> <ol style="list-style-type: none"> 1) When front of radar is covered with obstacles. (System status - blockage) message output 2) When location of radar mounted is distorted by external shocks. (Fault code sent) 3) BCW & LCA system failure. (fault code sent) 4) Radar overheating. (the system state - over temperature) message output <p>■ LCA System mode operation</p> <ol style="list-style-type: none"> 1. When start engine with switch in OFF, LCA system is OFF mode. 2. When press the ON switch from OFF mode, LCA system goes to passive mode. 3. When start engine with switch in ON, LCA system is passive mode. 4. While driving, if activation conditions (Speed, Change of curvature) is satisfied, LCA system mode changes from passive to active mode. (alert ON) 5. While driving, if activation conditions (Speed, Change of curvature) is not satisfied, LCA system goes to passive mode. (alert OFF) 6. When LCA system is malfunction in any mode, LCA system mode changes to failure mode. 7. When LCA system operates normally in failure mode, LCA system mode changes to OFF mode. 8. When OFF switch is pressed while LCA system in Active/Passive mode, LCA system mode changes to OFF mode. <p>■ Sensor Alignment</p> <p>Sensor's recognizing direction must be in aligned with drive direction of vehicle to operate normally.</p> <p>BCW sensor alignment is matching direction of the vehicle with sensor.</p> <p>Without performing BCW sensor alignment, it may causes false alarm or system malfunction due to poor detection performance.</p> <p>■ Auto-alignments must be done for bumper accident vehicle.</p>

Blind-Spot Collision Warning (BCW) System	Service Tips (2)																																							
<p>■ Diagnosis</p> <p>Diagnosis of BCW radar is performed only when vehicle speed faster than 7km/h with BCW switch is ON.</p> <p>If you check the wiring and connectors of radar, it is composed of power (IG1, Ground), communication (CAN-High, CAN-Low), outputs (Switch, left/right LED). Thus, main failure of system is internal fault, malfunction of power, circuit and communication.</p> <p>■ DTC Code and Actions</p> <table border="1"> <thead> <tr> <th>DTC</th> <th>Description</th> <th>Actions</th> </tr> </thead> <tbody> <tr> <td>C1101</td> <td>Battery power high</td> <td>Check battery, charger, cables, connectors</td> </tr> <tr> <td>C1102</td> <td>Battery power low</td> <td>Check battery, charger, cables, connectors</td> </tr> <tr> <td>C1616</td> <td>CAN communication line malfunction</td> <td>Check cables, connectors</td> </tr> <tr> <td>C160A</td> <td>Private CAN communication line malfunction</td> <td>Check cables, connectors</td> </tr> <tr> <td>C170A</td> <td>Switch LED circuit malfunction</td> <td>Check switch circuit short to ground</td> </tr> <tr> <td>C1501</td> <td>Switch malfunction</td> <td>Check push status of the switch</td> </tr> <tr> <td>C170C</td> <td>Right sensor ECU hardware malfunction</td> <td>Replace right side radar sensor</td> </tr> <tr> <td>C170D</td> <td>Left sensor ECU hardware malfunction</td> <td>Replace left side radar sensor</td> </tr> <tr> <td>C2702</td> <td>Right sensor Missing calibration</td> <td>Check mounting angle of the right side radar sensor</td> </tr> <tr> <td>C2703</td> <td>Left sensor Missing calibration</td> <td>Check mounting angle of the left side radar sensor</td> </tr> <tr> <td>-</td> <td>Blockage</td> <td>Check contamination of sensing element</td> </tr> <tr> <td>-</td> <td>high temperature</td> <td>Check contamination of sensing element</td> </tr> </tbody> </table>	DTC	Description	Actions	C1101	Battery power high	Check battery, charger, cables, connectors	C1102	Battery power low	Check battery, charger, cables, connectors	C1616	CAN communication line malfunction	Check cables, connectors	C160A	Private CAN communication line malfunction	Check cables, connectors	C170A	Switch LED circuit malfunction	Check switch circuit short to ground	C1501	Switch malfunction	Check push status of the switch	C170C	Right sensor ECU hardware malfunction	Replace right side radar sensor	C170D	Left sensor ECU hardware malfunction	Replace left side radar sensor	C2702	Right sensor Missing calibration	Check mounting angle of the right side radar sensor	C2703	Left sensor Missing calibration	Check mounting angle of the left side radar sensor	-	Blockage	Check contamination of sensing element	-	high temperature	Check contamination of sensing element	
DTC	Description	Actions																																						
C1101	Battery power high	Check battery, charger, cables, connectors																																						
C1102	Battery power low	Check battery, charger, cables, connectors																																						
C1616	CAN communication line malfunction	Check cables, connectors																																						
C160A	Private CAN communication line malfunction	Check cables, connectors																																						
C170A	Switch LED circuit malfunction	Check switch circuit short to ground																																						
C1501	Switch malfunction	Check push status of the switch																																						
C170C	Right sensor ECU hardware malfunction	Replace right side radar sensor																																						
C170D	Left sensor ECU hardware malfunction	Replace left side radar sensor																																						
C2702	Right sensor Missing calibration	Check mounting angle of the right side radar sensor																																						
C2703	Left sensor Missing calibration	Check mounting angle of the left side radar sensor																																						
-	Blockage	Check contamination of sensing element																																						
-	high temperature	Check contamination of sensing element																																						

Blind-Spot Radar - Description and Operation (Article 44694)

- Description

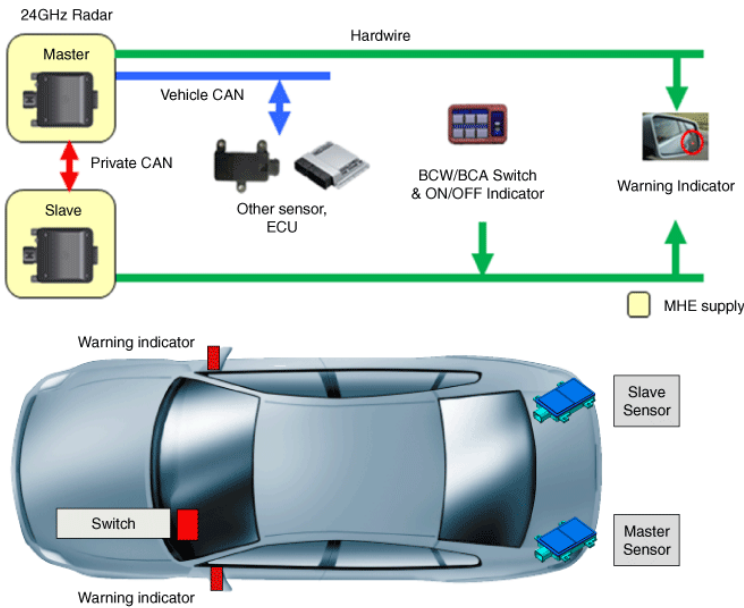

- Blind-Spot Collision Warning (BCW) : Senses other vehicles in the BCW zone and turns on the BCW warning lamp for the driver. Warning lamp starts blinking when the driver turns on the turn signal lamp to enter the lane where another vehicle is driving.
 - RCCW (Rear Cross-Traffic Collision Warning) : When the vehicle is on the reverse, the RCCW generates alarm to alert another vehicle approaching from the rear and side.
 - RCCA (Rear Cross-Traffic Collision-Avoidance Assist) : When the vehicle is on the reverse, the RCCA take brake to avoid another vehicle approaching from the rear and side.
 - BCA-R(Blind-Spot Collision-Avoidance Assist - Rear) : When the lane departure, BCA-R generates avoidance for another vehicle within the blind spot zone.
- System Operating Mode

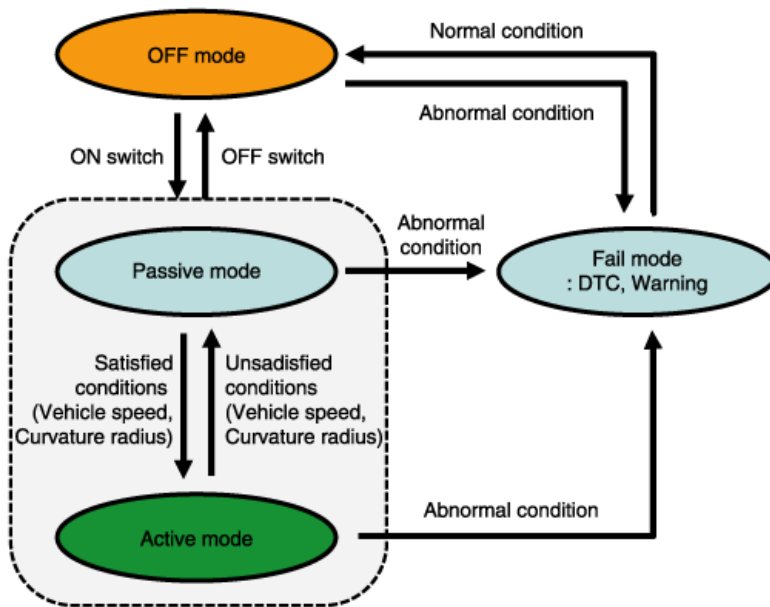

- When starting the engine with the switch off, OFF mode is on.
- When pressing ON switch in OFF mode, Passive mode is on.
- If starting the engine with the switch ON, Passive mode is on. ■ When IGN is ON, the switch is in the initial state : The last position is kept. If IGN OFF → ON with the switch ON, the switch is ON. If IGN OFF → ON with the switch OFF, the switch is OFF.
- If IGN OFF → ON with the switch ON, the switch is ON.
- If IGN OFF → ON with the switch OFF, the switch is OFF.
- If you start the engine with Blind-Spot switch ON, or if you turn on Blind-Spot Radar with Blind-Spot switch

- OFF, the warning lamp of the door mirror flickers for 2 to 3 seconds. This is to inform the driver that the Blind-Spot Radar system is ready. (provided that if the system is in Fail mode, there is no flickering.)
- If the activation conditions (speed and curvature radius) are met while driving, Active mode is on (warning issued).
 - If the activation conditions (speed and curvature radius) are not met while driving, Passive mode is on (warning removed).
 - If BCW & LCA operation fails in any mode, Fail mode is on.
 - If BCW & LCA operation operates normally in Fail mode, OFF mode is on.
 - If pressing OFF switch while BCW & LCA function is operating (Active/Passive), OFF mode is on.
- Warning Condition
- Warning zone

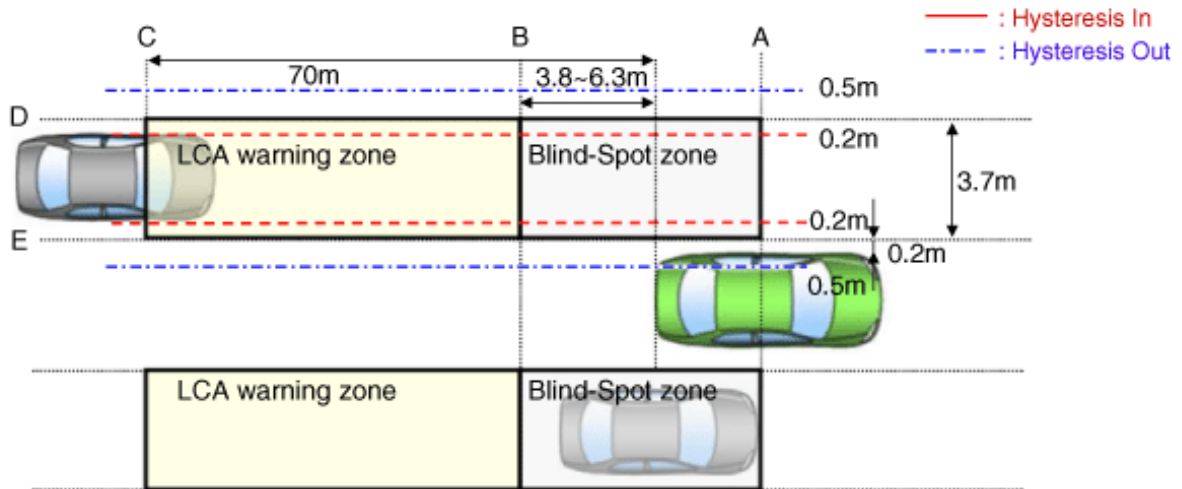

- Conditions for BCW warning ON ① The entire body of the target vehicle is located behind the line A. ② Any part of the target vehicle pass the line B. ③ Any part of the target vehicle passes the line D and Hysteresis In. ④ The entire part of the target vehicle passes the line E and Hysteresis In.

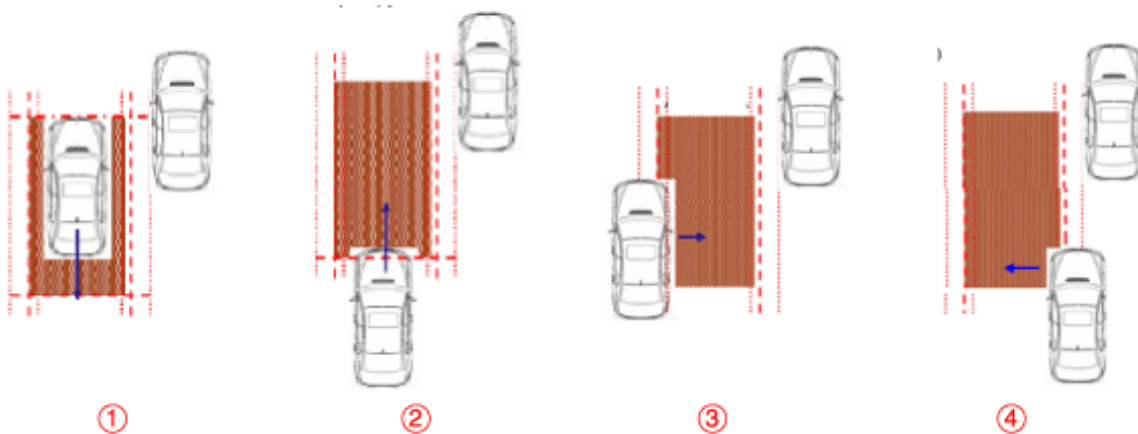

- Conditions for BCW warning OFF ① The entire body of the target vehicle moves before the line A. ② The entire body of the target vehicle moves behind the line B. ③ The entire body of the target vehicle passes the line D and Hysteresis Out. ④ The entire part of the target vehicle passes the line E and Hysteresis Out.

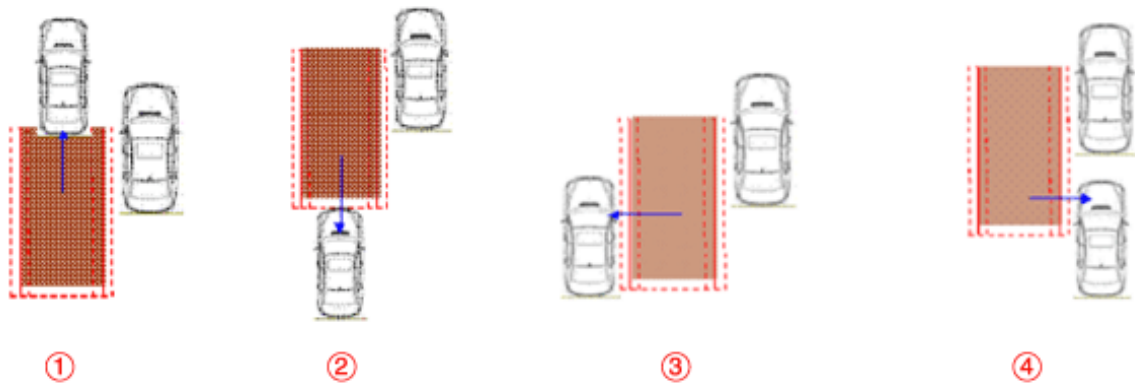

- Conditions for LCA warning ON ① The entire body of the target vehicle is located behind the line B. ② Any part of the target vehicle pass the line C. ③ Any part of the target vehicle passes the line D and Hysteresis In. ④ The entire part of the target vehicle passes the line E and Hysteresis In. ⑤ In the all above condition, TTC(Time to Collision) is not less than 4.5 sec.

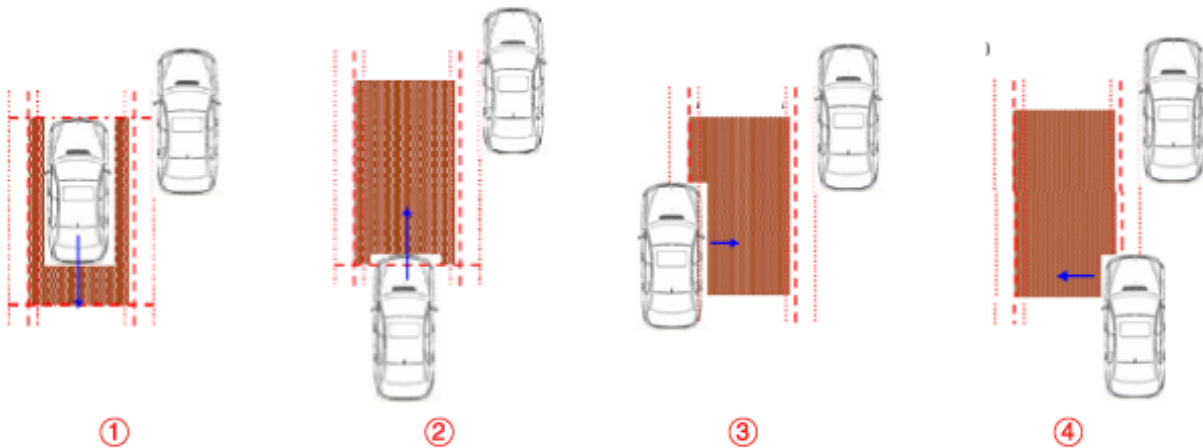

- Conditions for LCA warning OFF ① The entire body of the target vehicle is located before the line B. ② The entire body of the target vehicle pass the line C. ③ The entire body of the target vehicle passes the line D and Hysteresis Out. ④ The entire body of the target vehicle passes the line E and Hysteresis Out. ⑤ In the all above condition, TTC(Time to Collision) is more than 4.5 sec.

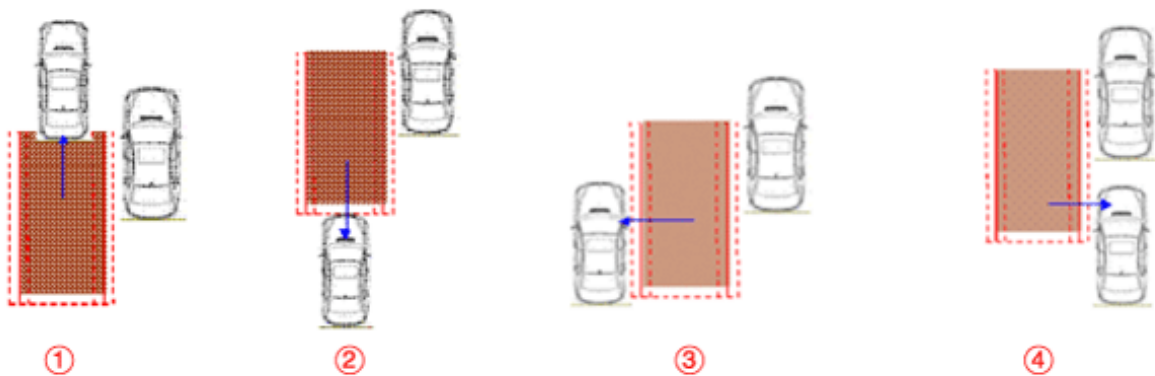

- Sensor activation conditions ① BCW & LCA switch (indicated by the switch LED) is on. ② Vehicle Speed : 30 km/h or faster ③ Curvature radius : 100m or more ④ Relative car speed : -15 - 255km/h ("- " means overtaking the preceding vehicle)

- Sensor deactivation conditions ① BCW & LCA switch (indicated by the switch LED) is off. ② Vehicle Speed : 28 km/h or slower ③ Curvature radius : 70m or less ④ Relative car speed : All except -15 - 255km/h ("- " means overtaking the preceding vehicle)

- System control prohibition ① The radar is covered by debris : System conditions - Blockage message is outputted If the sensor on the rear bumper is contaminated by snow, mud or stickers, its detecting performance may be lowered. ② The radar installation is damaged by an outside shock: Send the error code ③ BCW & LCA system fails : Send the error code ④ The radar is overheated : System conditions - Over Temperature message is outputted.
 If the sensor on the rear bumper is contaminated by snow, mud or stickers, its detecting performance may be lowered.

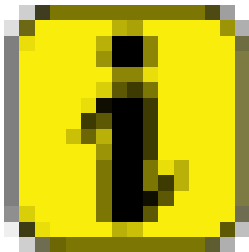

Information

- Rear Cross-Traffic Collision Warning System (RCCW) Item Control value Remarks Activation speed 0 to -10 km/h (Reverse) Activate when the gear is shifted to R (Reverse) position Time To Collision 8 km/h - 40 km/h + : closing Activation distance 0.5m - 25m Vehicle basis ① Generates warning in case of collision risk with the vehicle approaching from left and right side of your vehicle while reversing out of the parking space. ② Based on the Time To Collision (TTC), the warning is generated for the vehicle that is possible to collide within 3.5 seconds. "Time To Collision (TTC) : Time calculated using the relative distance/speed which is the time until the possible collision. (TTC is subject to change depending on the relative speed of the approaching vehicle)." ③ Warning zone is as follows :

Item Control value Remarks

Activation speed 0 to -10 km/h (Reverse) Activate when the gear is shifted to R (Reverse) position

Time To Collision 8 km/h - 40 km/h + : closing

Activation distance 0.5m - 25m Vehicle basis

"Time To Collision (TTC) : Time calculated using the relative distance/speed which is the time until the possible collision. (TTC is subject to change depending on the relative speed of the approaching vehicle)."

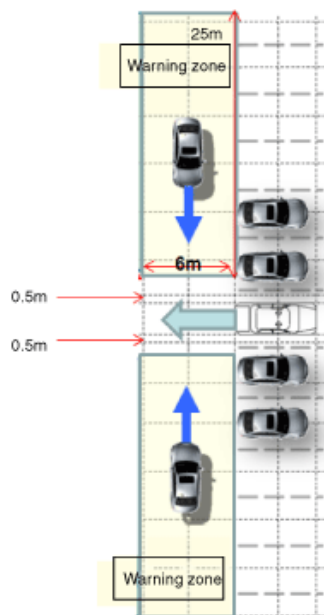

- BCA-R (Blind-Spot Collision-Avoidance Assist System - Rear) Item Control value Remarks Activation speed 60 - 180 km/h Same front camera operation condition

Activation speed 60 - 180 km/h Same front camera operation condition

- RCCA (Rear Cross-Traffic Collision-Avoidance Assist System) Item Control value Remarks Activation speed -1 to -10 km/h (Reverse) Activate when the gear is shifted to R (Reverse) position Time To Collision 8 km/h - 40 km/h + : closing Activation distance 0.5m - 25m Vehicle basis ① The brake is applied if the vehicle does not stop even the warning is generated due to the collision risk while reversing out of the parking space. ② Based on the Time To Collision brake is applied for the vehicle within 2 seconds. "Time To Collision (TTC) : Time

calculated using the relative distance/speed which is the time until the possible collision. (TTC is subject to change depending on the relative speed of the approaching vehicle)."

Activation speed -1 to -10 km/h (Reverse) Activate when the gear is shifted to R (Reverse) position

Parking Distance Warning - Description and Operation (Article 44665)

- System Overview

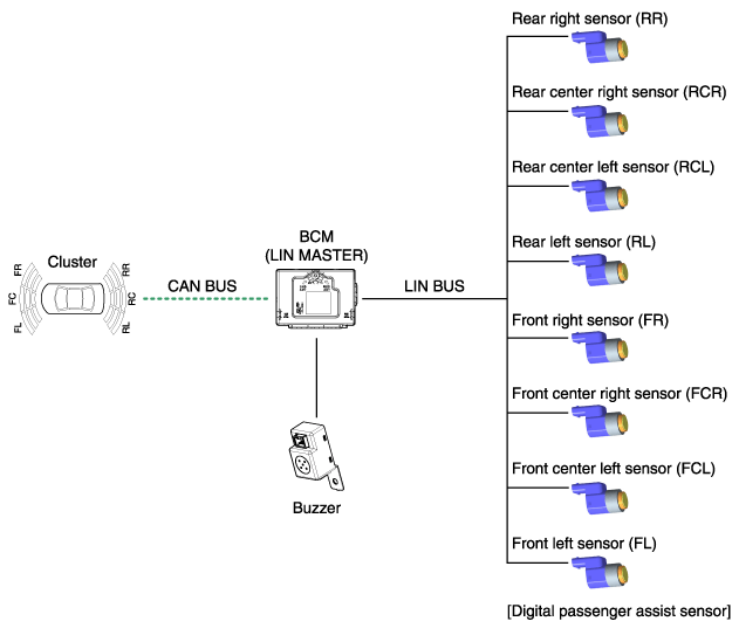

System Operation Specification.

- INIT mode System initializing time is 500ms after IGN1+ R Gear. PDW recognizes LID and sets the sensor ID up during initialization. PDW activates each sensor and then executes the diagnosis after finishing initialization of BCM. If the diagnosis is completed and sensor does not send an error message, "PDW Startling Buzzer" is normally worked. If failure is received from any sensors, "PDW Starting Buzzer" does not work but the failure alarm is operated for a moment. If you have display option, warning sign is also shown on it. Buzzer for sensor failure is operated once, but the sensor failure state is shown in display until the failure is repaired.
- System initializing time is 500ms after IGN1+ R Gear.
- PDW recognizes LID and sets the sensor ID up during initialization.
- PDW activates each sensor and then executes the diagnosis after finishing initialization of BCM
- If the diagnosis is completed and sensor does not send an error message, "PDW Startling Buzzer" is normally worked.
- If failure is received from any sensors, "PDW Starting Buzzer" does not work but the failure alarm is operated for a moment. If you have display option, warning sign is also shown on it.
- Buzzer for sensor failure is operated once, but the sensor failure state is shown in display until the failure is repaired.
- NORMAL Mode Lin communication starts and keeps the routine after IGN1 ON+R gear BCM sends a message once to each sensor for operating request to check the initial status of the system and four sensors response all at once. At this time, if there is no problem, the alarm starts after 500ms of R gear shifting at 300ms intervals. After initialization, normal mode starts 100ms later after finishing alarm output. Alarm for obstacles is divided into 3 levels. The first and second are intermittent sound, and the third alarms continuously. The efficient vehicle speed of PDW operation is below 10Km/h. Refer to 'Digital PAS Project LIN communication' for the more detailed communication specification.
- Lin communication starts and keeps the routine after IGN1 ON+R gear
- BCM sends a message once to each sensor for operating request to check the initial status of the system and four sensors response all at once. At this time, if there is no problem, the alarm starts after 500ms of R gear shifting at 300ms intervals.
- After initialization, normal mode starts 100ms later after finishing alarm output.
- Alarm for obstacles is divided into 3 levels. The first and second are intermittent sound, and the third alarms continuously
- The efficient vehicle speed of PDW operation is below 10Km/h.
- Refer to 'Digital PAS Project LIN communication' for the more detailed communication specification.

Sensing Area

- Measurement condition – PVC pole (diameter 75mm, length 1m), normal temperature
 - Distance range detected objects (Measured directly in front of sensor) 61cm(24.0in) - 120cm(47.2in) : ± 15cm(5.9in) 31cm(12.2in) - 60cm(23.6in): ± 15cm(5.9in) Less than 30cm(11.8in) : ± 10cm(3.9in)
- Horizontal Sensing Area

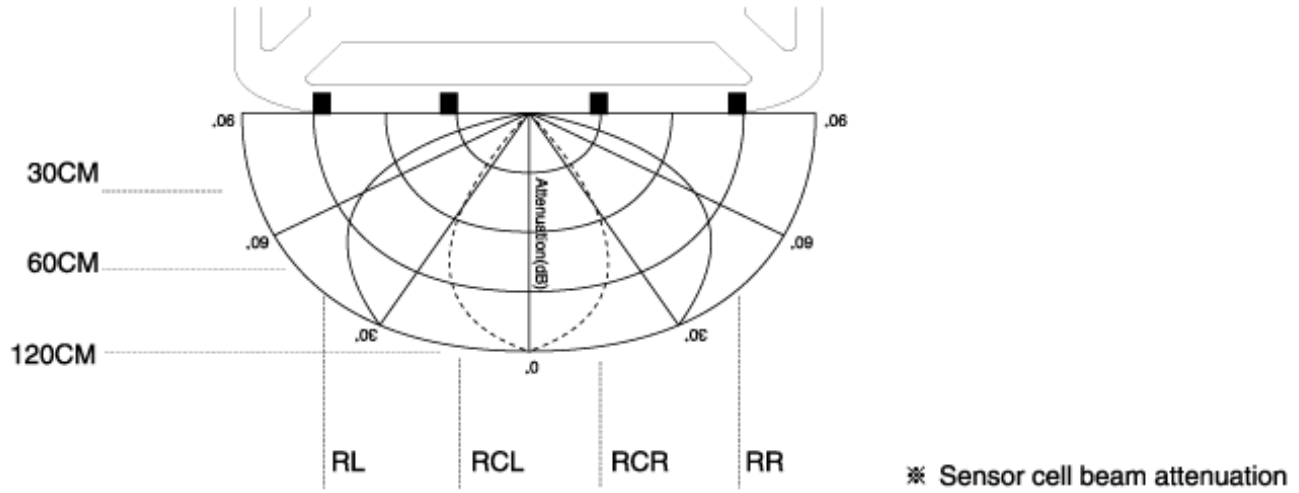

Vertical Sensing Area

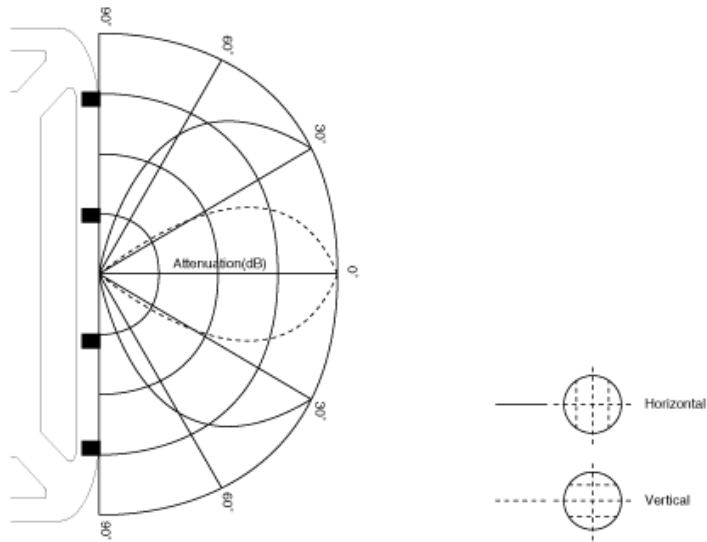

Distance Measurement
Direct Measurement

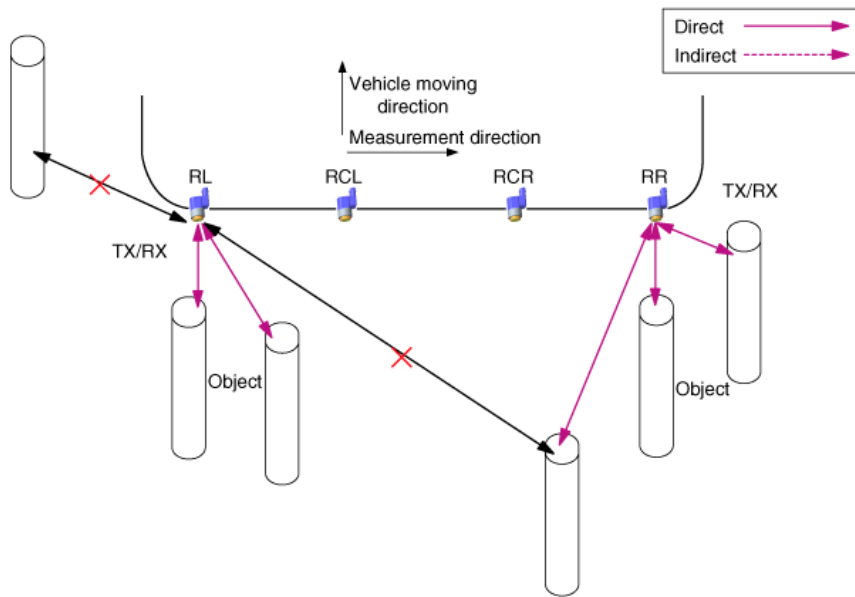

Indirect Measurement

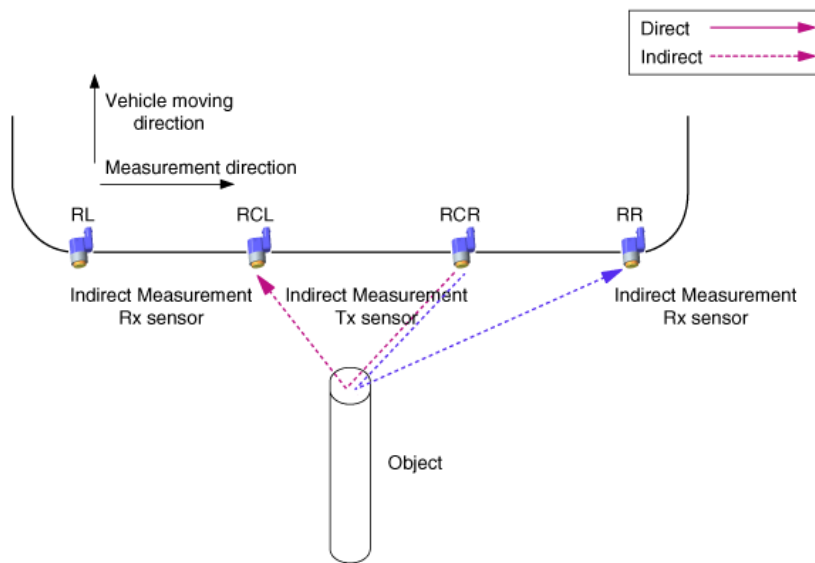

Direct and Indirect Measurement at once

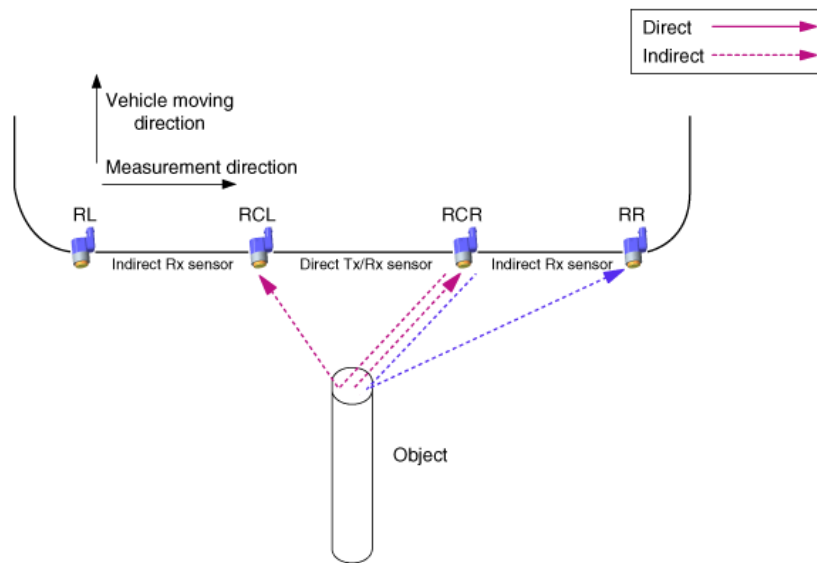

PDW Alarm System

- Sensor buzzer/display information processing method of BCM In case of RL/RR sensor information, the BCM handles each sensor information directly about Display and buzzer output function. Buzzer output of CL/CR sensor, BCM handles center combination information by priority both sensor.

System Operation Spec

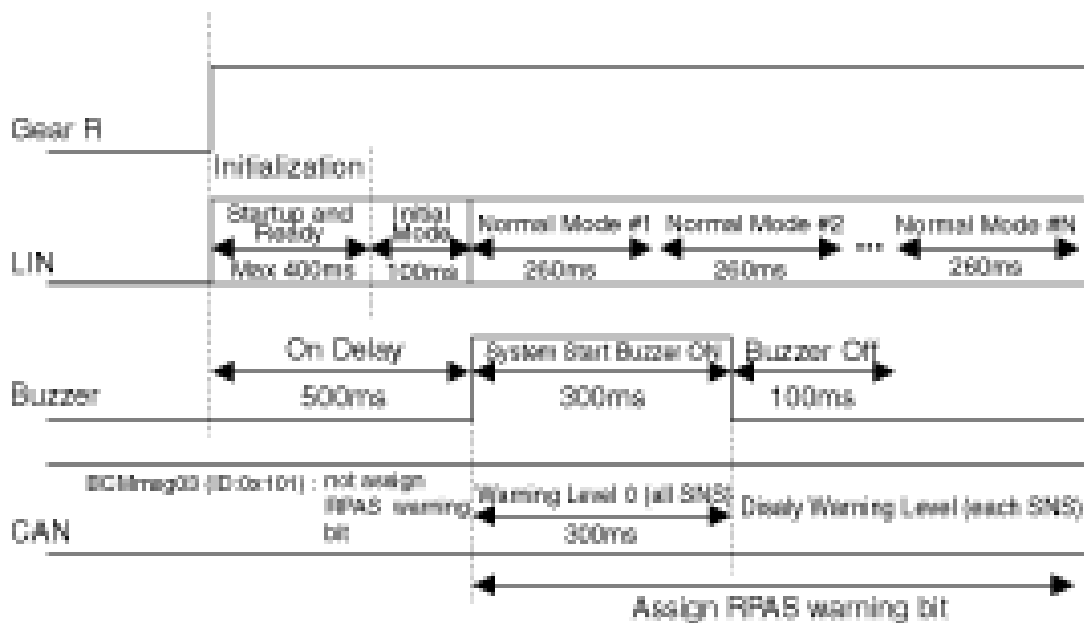

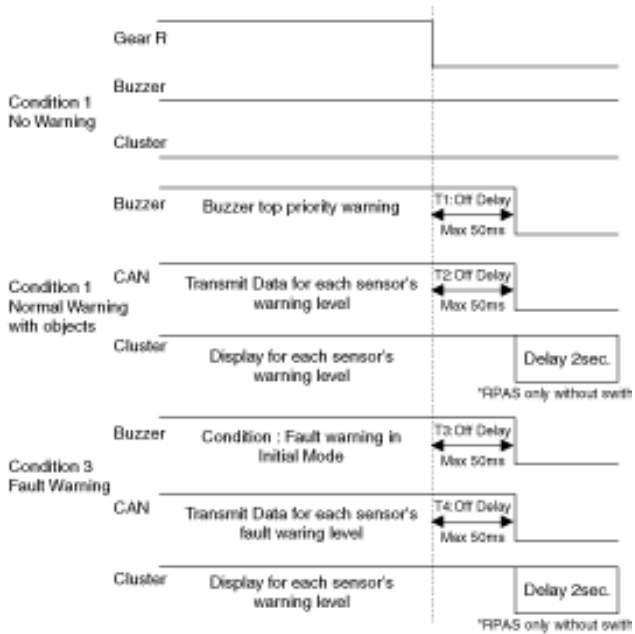
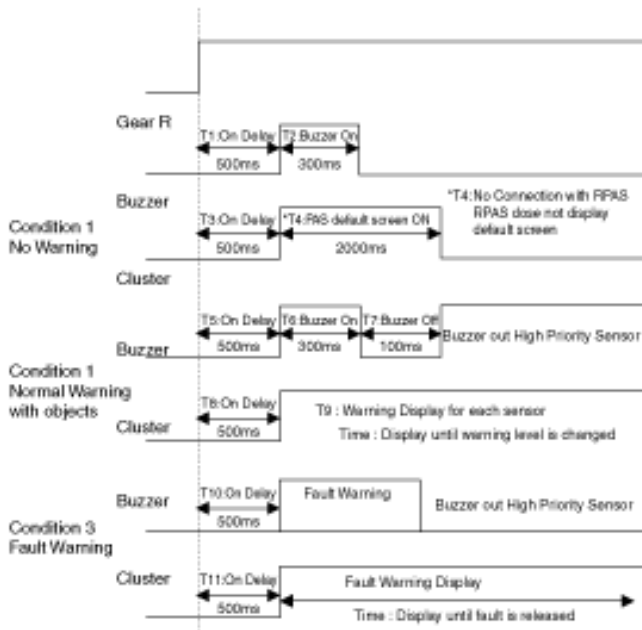

Alarm Output Specification Classified by Distance Between Sensors

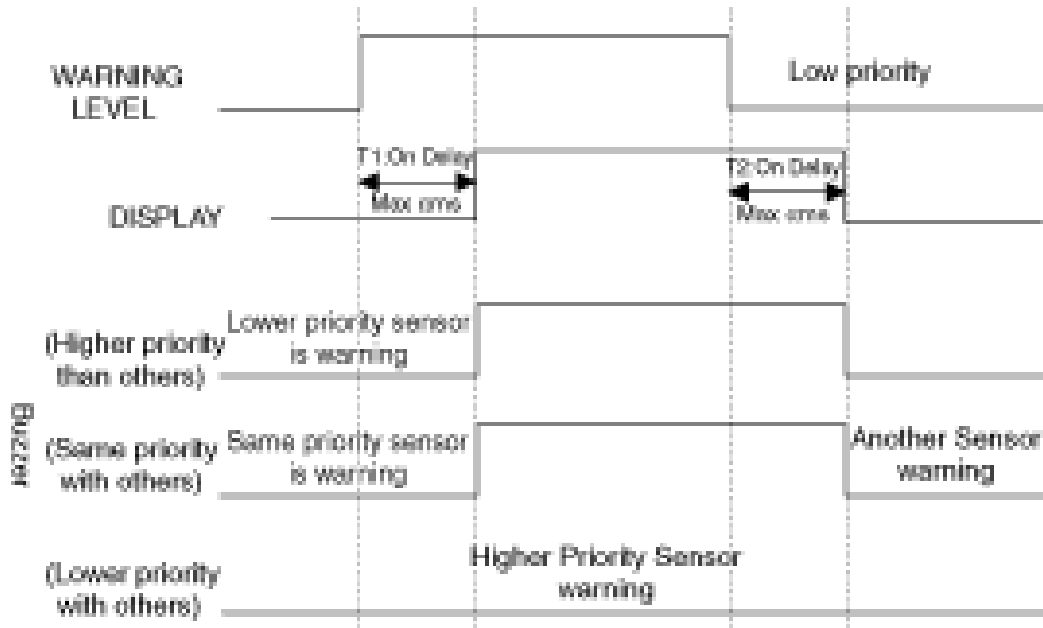

- low priority sensor off : $\alpha = 0\text{ms}$
- low priority sensor is 1st warning level : $\alpha < 340\text{ms}$
- low priority sensor is 2nd warning level : $\alpha < 170\text{ms}$
- low priority sensor is 1st warning level : $\beta = 1700\text{ms}$
- low priority sensor is 2nd warning level : $\beta = 1700\text{ms}$
- low priority sensor is 3rd warning level : $\beta = 700\text{ms}$
- First warning area (61cm-120cm)

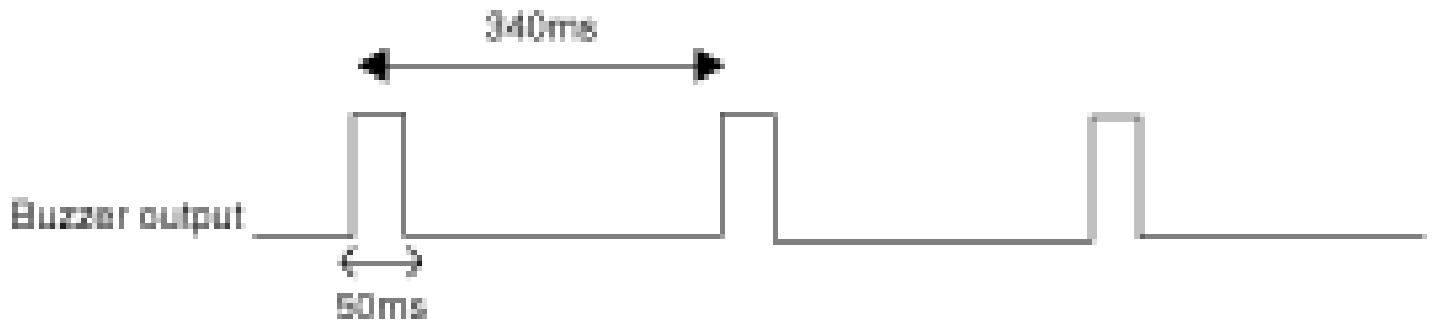

- Second warning area (31cm-80cm)

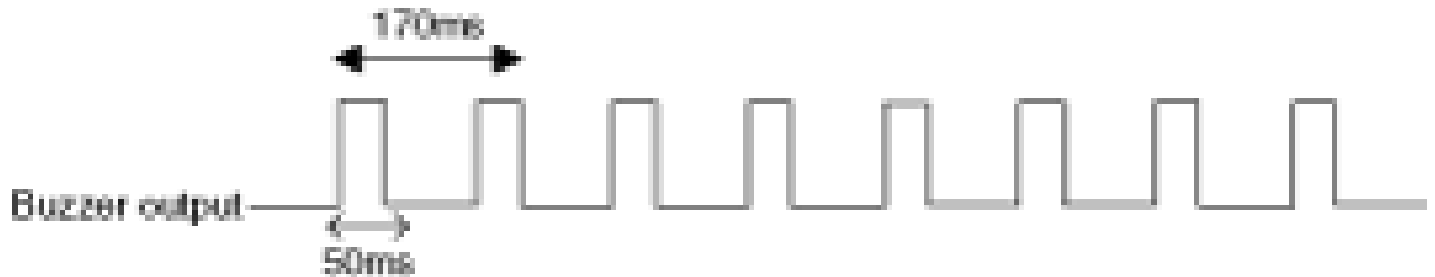

- Third warning area (less than 30cm)



- Alarm for ultrasonic sensor: If one or more front/rear parking assistance sensors have any fault, an alarm will be triggered.

sound and warning message will be displayed (cluster). Alarm sound Alarm message Displayed image and warning message may vary depending on the vehicle model.

- Alarm sound

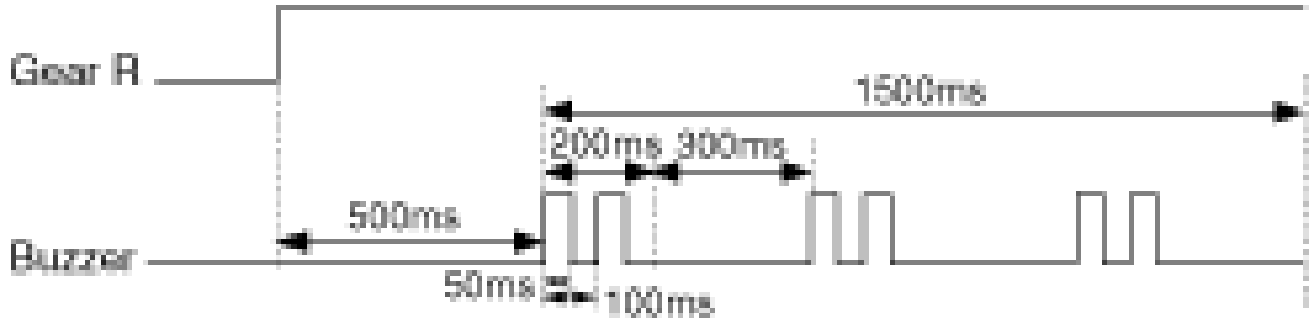

- Alarm message Displayed image and warning message may vary depending on the vehicle model.



Displayed image and warning message may vary depending on the vehicle model.



Visible Alarm Indicator Specification

Shift lever	Warning level	Front inside		Front outside		Warning area
D	1st (61~100cm) beep-beep-beep--	Beeping sound : ON Display : ON		Beeping sound : OFF Display : OFF		
	2nd (31~100cm) beep-beep-beep-	Beeping sound : ON Display : ON				
	3rd (0~30cm) beepbeepbeep	Beeping sound : ON Display : ON				
Shift lever	Warning level	Rear inside	Rear outside	Front inside	Front outside	Warning area
R	1st Rear : 61~120cm Front : 61~100cm beep-beep-beep--	Beeping sound : ON Display : ON	Beeping sound : OFF Display : OFF			
	2nd (31~100cm) beep-beep-beep-	Beeping sound : ON Display : ON	Beeping sound : OFF Display : OFF	Beeping sound : ON Display : ON	Beeping sound : ON Display : ON	
	3rd (0~30cm) beepbeepbeep	Beeping sound : ON Display : ON	Beeping sound : OFF Display : OFF	Beeping sound : ON Display : ON	Beeping sound : ON Display : ON	

- It shows only the detecting position of obstacles.
- In third level alarm, indicator flickers at intervals of a second.
- In normal alarm mode, integrated display of RCR/RCL Communication Standard

Parking Distance Warning Switch - Schematic Diagrams (Article 44670)

- Circuit Diagram
- [Automatic Transaxle Type]

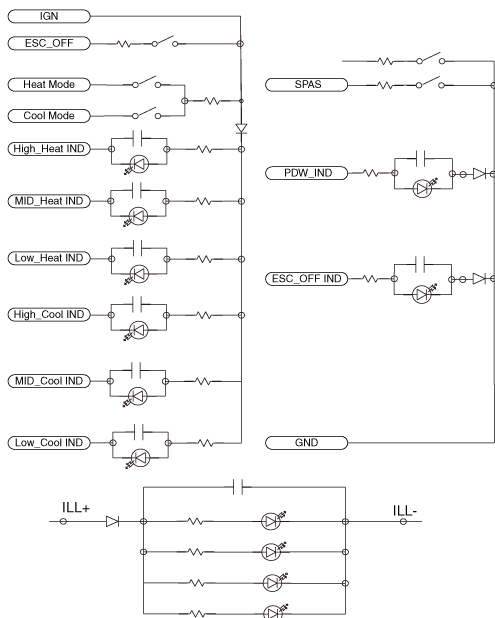

Autonomous Emergency Braking (AEB) System - Schematic Diagrams (Article 45219)

- Schematic diagram

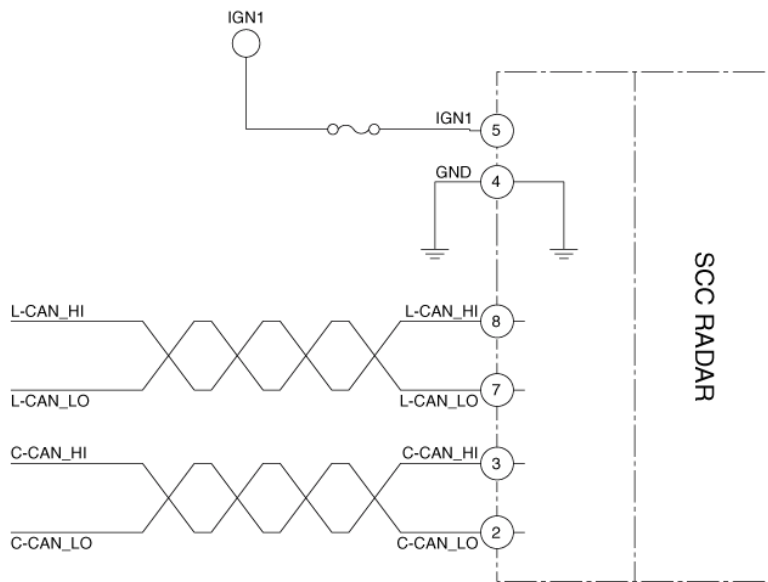

- Terminal Function

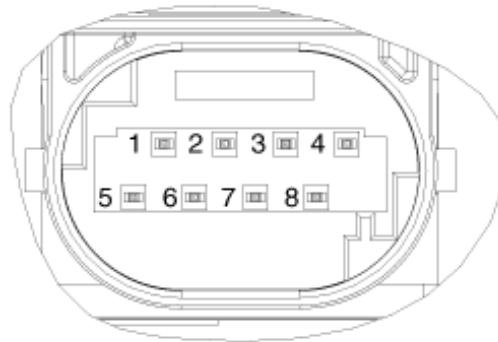

No Function

1 -

2 C-CAN Low

3 C-CAN High

4 GND

5 IGN_1

6 -

7 L-CAN Low

8 L-CAN High

Blind-Spot Collision Warning (BCW) System - Schematic Diagrams (Article 42599)

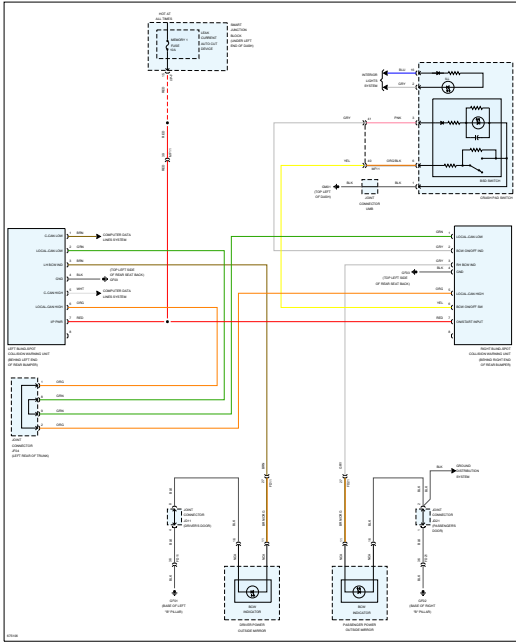

Lane Keeping Assist Circuit (Article 12451)

Lane Keeping Assist Circuit

Page 1 of 1

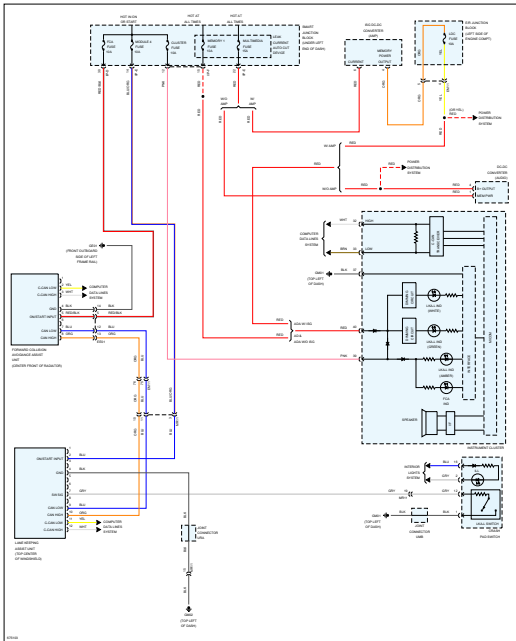

Parking Assistant Circuit (Article 12305)

Parking Assistant Circuit

Page 1 of 1

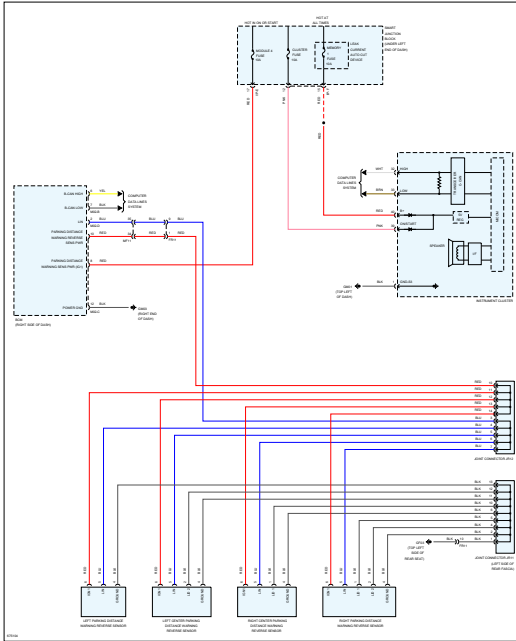

Autonomous Emergency Braking (AEB) System - Components and Components Location (Article 45217)

- Components
- Detection device (radar and camera) that can recognize potential obstacles in the front.
- Human-Machine Interface (HMI) to warn driver or change settings.
- Braking system to automatically brake the car

► AEB SYSTEM

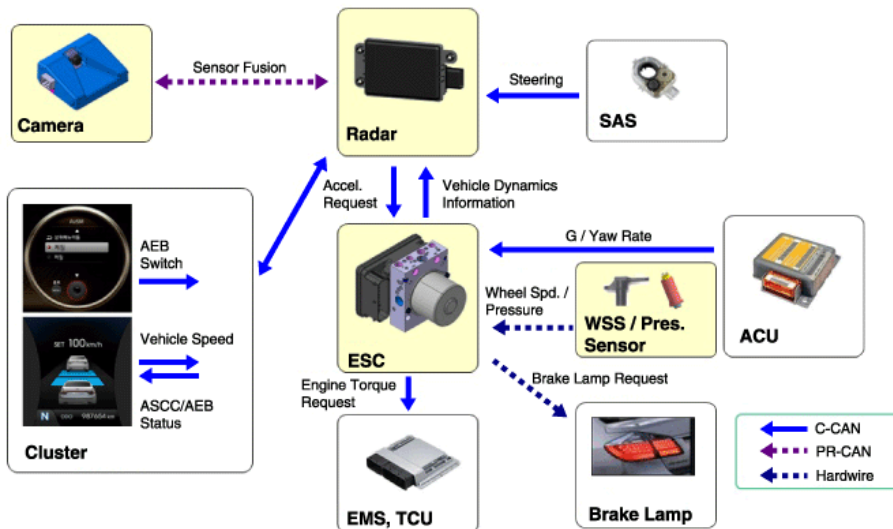

Blind-Spot Radar - Components and Components Location (Article 44693)

- Components

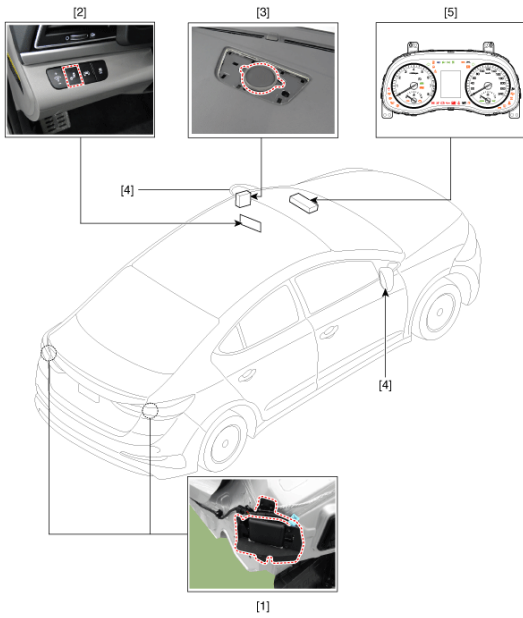

1. Blind-Spot Radar Unit 2. Blind-Spot Radar switch 3. Speaker 4. Blind-Spot Radar warning lamp 5. Cluster

Blind-Spot Radar System - Components and Components Location (Article 44700)

- Circuit Diagram

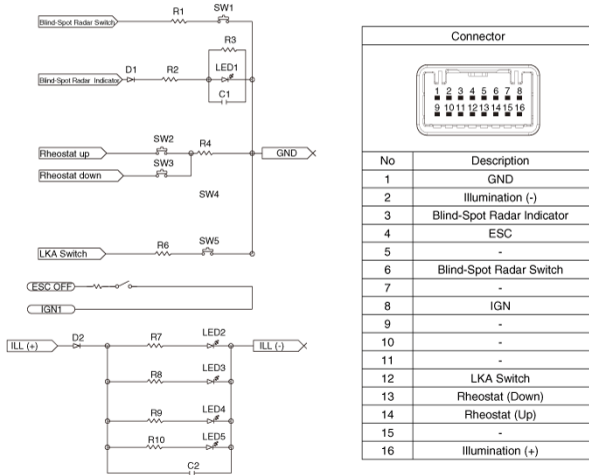
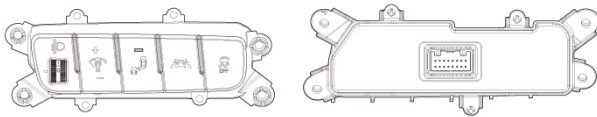

No	Description
1	GND
2	Illumination (-)
3	Blind-Spot Radar Indicator
4	ESC
5	-
6	Blind-Spot Radar Switch
7	-
8	IGN
9	-
10	-
11	-
12	LKA Switch
13	Rheostat (Down)
14	Rheostat (Up)
15	-
16	Illumination (+)

Component Location and Function (Parking Guide System) (Article 39317)

- Rear camera
Rear camera

**Image not available at the
time of publish.**

1. Rear View Camera
- Navigation
Navigation

**Image not available at the
time of publish.**

1. Navigation

Component Location and Function (SBW Control Unit) (Article 39415)

- FCA Control Module
FCA Control Module

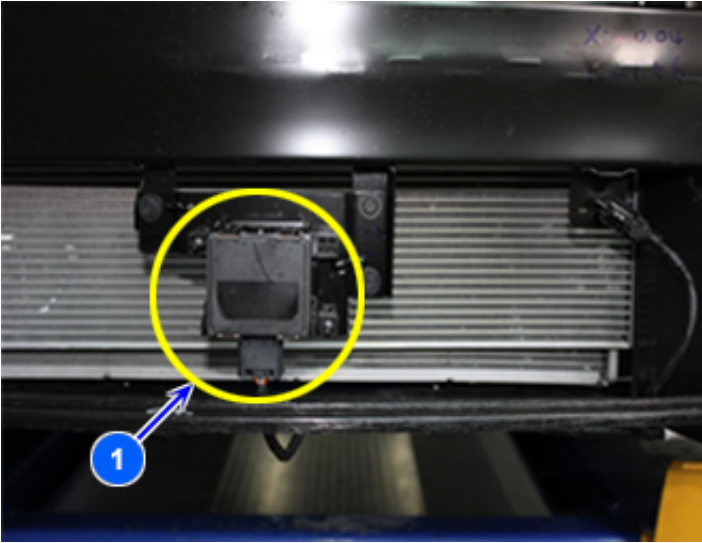

1. FCA Control Module (radar installed)
- Wheel Speed Sensor
Wheel Speed Sensor

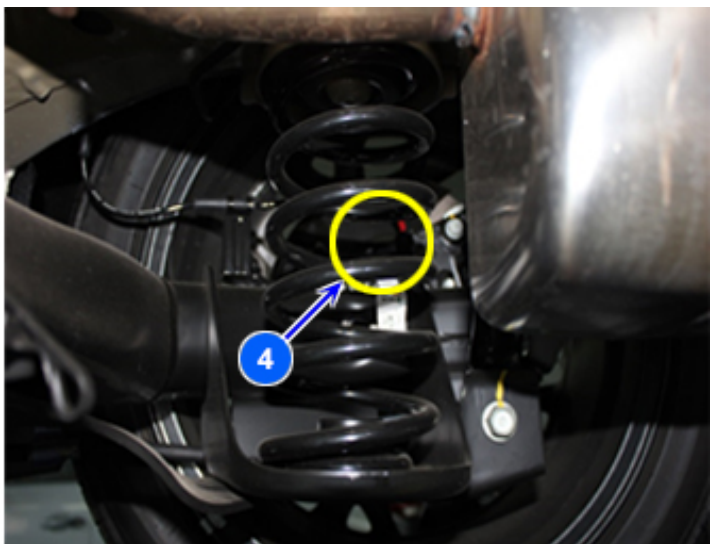

1. Front Left Wheel Speed Sensor
2. Front Right Wheel Speed Sensor
3. Rear Left Wheel Speed Sensor
4. Rear Right Wheel Speed Sensor

- Steering Angle Sensor
Steering Angle Sensor



1. MDPS, Steering Angle Sensor
- Yaw rate and Lateral Sensor
Yaw rate and Lateral Sensor



1. SRSCM (Airbag Control Module: Yaw rate and G sensor installed)
- ESP(ESC) Control Module
ESP(ESC) Control Module



1. ESP(ESC) Control module (ABSCM and Hydraulic Unit)
- LKA-L(Lane Keeping Assistance-Line)
LKA-L(Lane Keeping Assistance-Line)



1. LKA-L(Lane Keeping Assist-Line)
- PCM(ECM/TCM)
PCM(ECM/TCM)

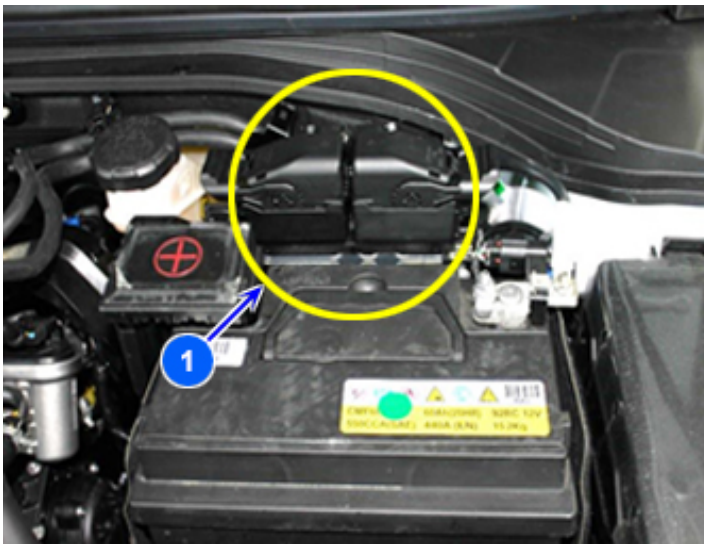

1. PCM(ECM/TCM)



- Cluster
Cluster



1. Cluster
- IGPM
IGPM

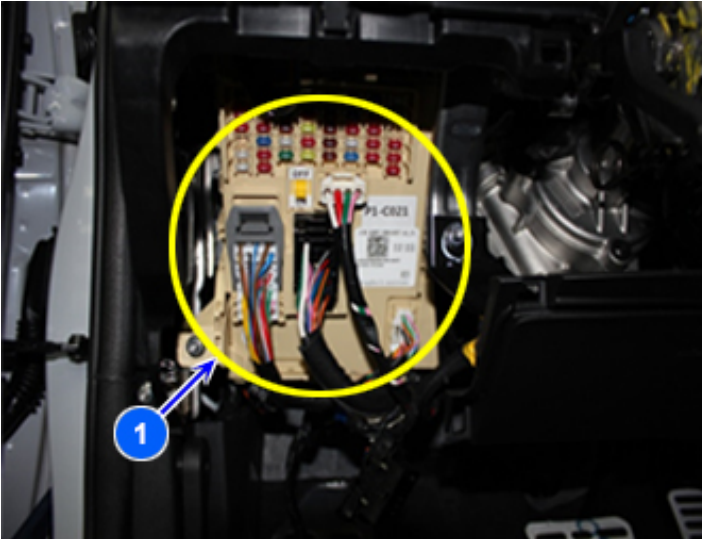

1. IGPM (Integrated Gateway & Power control Module)

Parking Distance Warning - Components and Components Location (Article 44664)

- Component Location

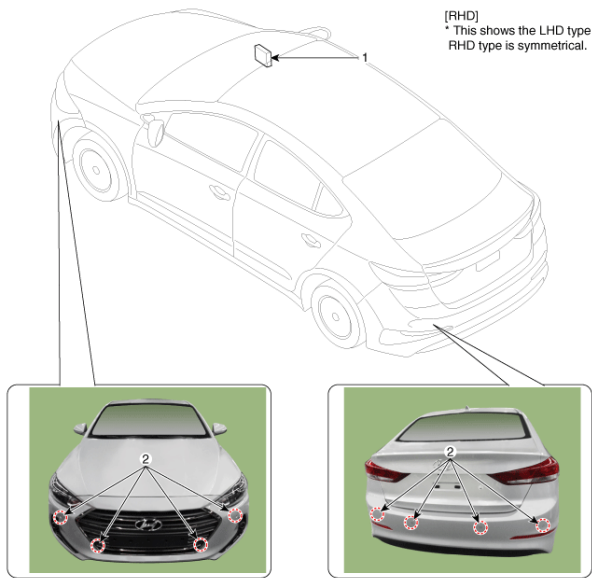

1. BCM (Body Control Module) 2. Ultrasonic sensor
Parkin Distance Warning (PDW) control unit function is built in BCM (Body Control Module).



Information

- Parkin Distance Warning (PDW) control unit function is built in BCM (Body Control Module).

Parking Distance Warning Switch - Components and Components Location (Article 44668)

- Component
[Automatic Transmission Type]

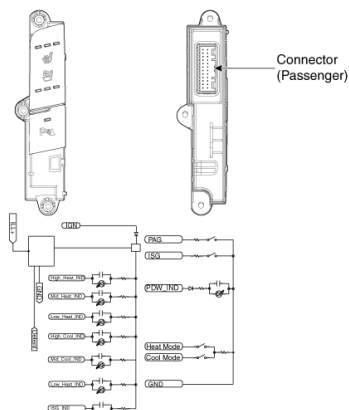

Connector (Passenger)	No	Description	No	Description
	1	Ground	13	Illumination (-)
	2	-	14	-
	3	Ventilation indicator (Mid)	15	Heater switch
	4	Heater indicator (High)	16	Ventilation switch
	5	Ventilation indicator (High)	17	-
	6	Ventilation indicator (Low)	18	-
	7	-	19	-
	8	-	20	-
	9	Heater indicator (Mid)	21	Heater indicator (Low)
	10	PDW Switch	22	PDW Indicator
	11	ESC OFF	23	ESC OFF Indicator
	12	IGN	24	Illumination (+)

Blind-Spot Radar - Repair Procedures (Article 44695)

- Diagnosis with GDS
- Blind-Spot Radar system defects can be quickly diagnosed with the GDS. GDS operates actuator quickly to monitor, input/output value and self diagnosis.
- Connect the cable of GDS to the data link connector in driver side crash pad lower panel, turn the power on GDS.
- Select the vehicle model and then BSD system.
- Select "Input/output monitoring", if you want to check current data of BSD system.

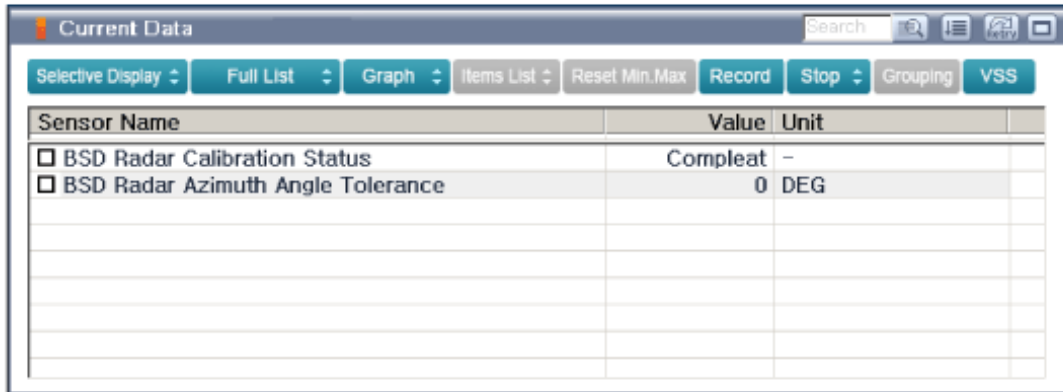

Sensor Name	Value	Unit
<input type="checkbox"/> BSD Radar Calibration Status	Compleat	-
<input type="checkbox"/> BSD Radar Azimuth Angle Tolerance	0	DEG

- If you want to check each module operation forcefully, select "Actuation test".
- Ignition "OFF", connect GDS.
- Ignition "ON" & Engine "OFF", select BSD system and "BSD Radar Calibration" mode.

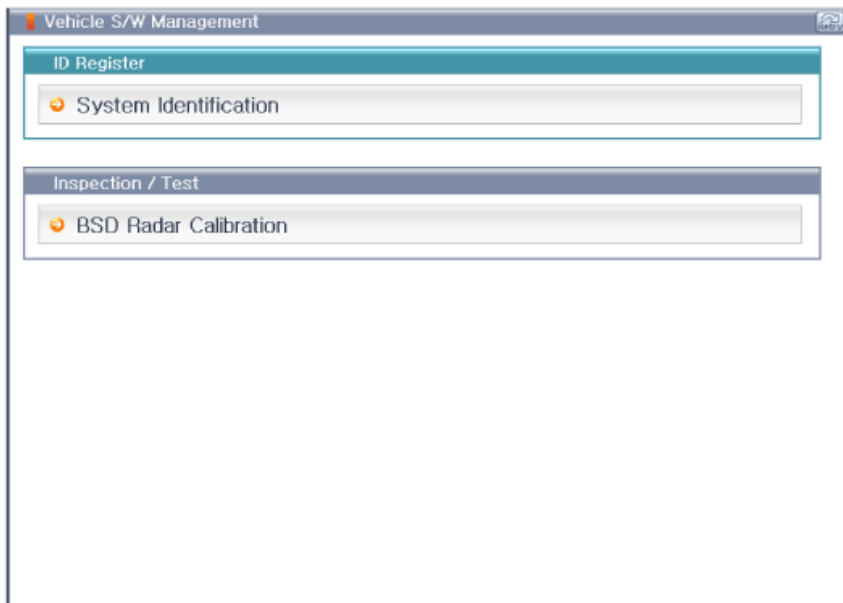

- The GDS will show the BSD Reset function steps. Erase BSD diagnostic codes. BSD initialization.
- Erase BSD diagnostic codes.
- BSD initialization.

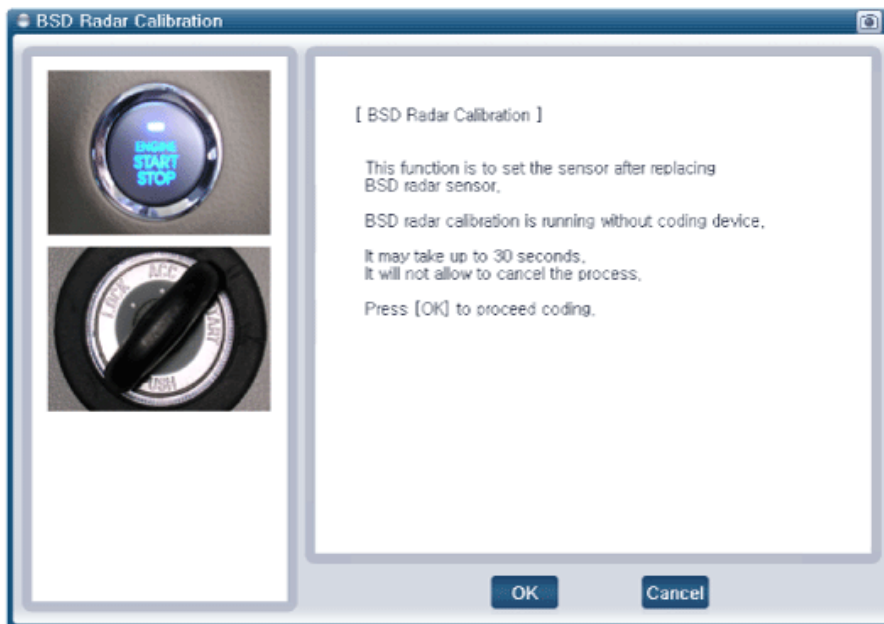

- The BSD initialization procedure will be performed.

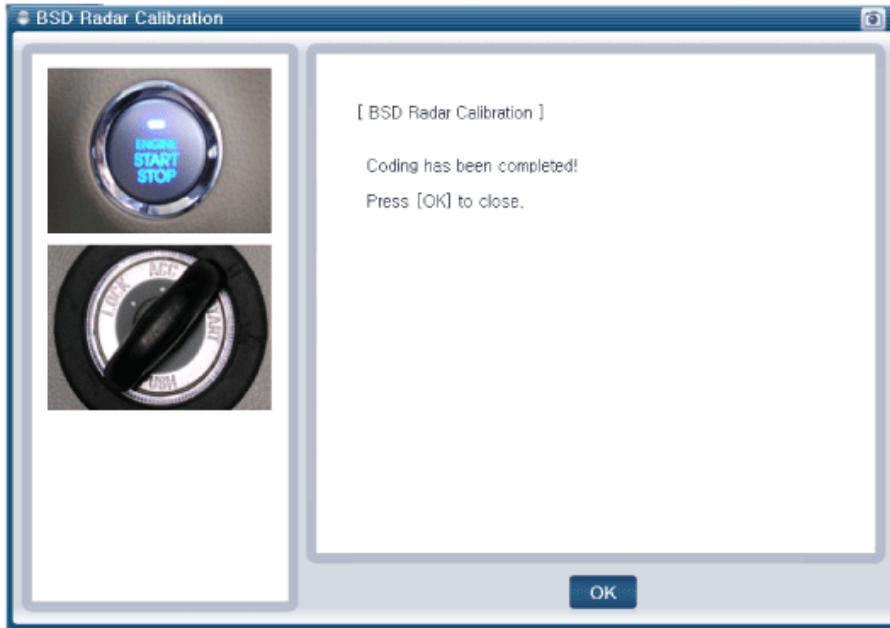

Parking Distance Warning Switch - Repair Procedures (Article 44671)

- Removal

Put on gloves to prevent hand injuries.



- Put on gloves to prevent hand injuries.

When removing with a flat-tip screwdriver or remover, wrap protective tape around the tools to prevent damage to components. Use a plastic panel removal tool to remove interior trim pieces without marring the surface. Take care not to bend or scratch the trim and panels.



- When removing with a flat-tip screwdriver or remover, wrap protective tape around the tools to prevent damage to components.

- Use a plastic panel removal tool to remove interior trim pieces without marring the surface.

- Take care not to bend or scratch the trim and panels.

- Disconnect the negative (-) battery terminal.

- Remove the floor console upper cover. (Refer to Body - "Floor Console Assembly")

- Remove the PDW switch (A) from the floor console upper cover after loosening mounting screws.

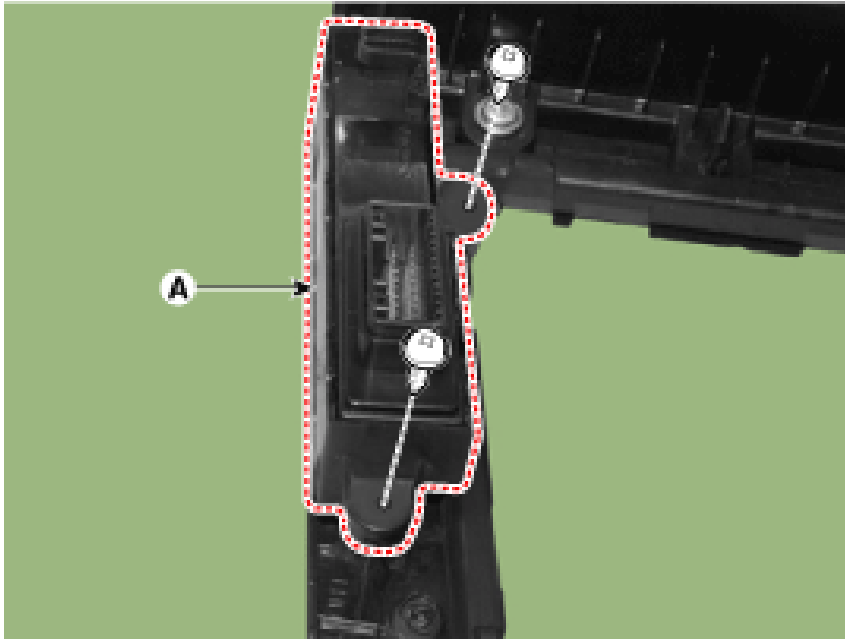

- Installation
- Install the PDW switch.
- Install the floor console upper cover.
- Connect the negative (-) battery terminal. Make sure that the connectors are plugged in properly. Check the PDW system for normal operation.
- Make sure that the connectors are plugged in properly. Check the PDW system for normal operation.
- Make sure that the connectors are plugged in properly.
- Check the PDW system for normal operation.

Blind-Spot Radar - Specifications (Article 44692)

- Specifications
- Items Blind-Spot Collision Warning (BCW) Blind-Spot Collision- Avoidance Assist-Rear (BCA-R)
- Rated voltage DC 12V
- Operating voltage 9V - 16V
- Operating speed 30 km/h - 255 km/h 60 km/h - 180 km/h
- Sensible distance 70m
- Curvature radius Start : More than 100m Start: More than 625m
- Stop : Less than 70m Stop : Less than 588m
- Frequency 24 GHz
- Numbers 2EA
- Items Rear Cross-Traffic Collision Warning (RCCW) Rear Cross-Traffic Collision- Avoidance Assist (RCCA)
- Operating speed 0 km/h - 10 km/h 1 km/h - 10 km/h
- Sensible distance 25m
- Curvature radius -

Parking Distance Warning - Specifications (Article 44663)

- Specification
- Item Specification
- Ultrasonic sensor Voltage rating DC 12V
- Detecting range Front : 100 / 60 /30 cm Rear : 120 / 60 /30 cm
- Operation voltage DC 9 - 16V
- Operation current MAX 350 mA
- Operation temperature -30°C to +80°C (-22°C to +176°C)
- Operation frequency 48 ± 5 KHz
- Number of sensors 8EA

All New Technical Service Bulletins (itype_432)

Tsbs

All Technical Service Bulletins (itype_100)

Tsbs

- PARKING ASSIST SYSTEM (PAS) DIAGNOSTIC GUIDE (19-BE-005H, 2019/03/15)
- BLIND-SPOT RADAR REPLACEMENT, AND MOUNTING ANGLE VALIDATION (19-BE-016H, 2019/10/14)
- Blind-Spot Collision Warning (BCW) Parts Information (21-BE-011H, 2021/08/16)
- BLIND SPOT DETECTION (BSD) OR BLIND-SPOT COLLISION WARNING (BCW) (19-BE-011H-1, 2019/11/04)
- REAR-VIEW MONITOR INSPECTION GUIDE (25-BE-024H, 2025/12/16)
- BLIND-SPOT COLLISION WARNING (BCW/BSD) MODULE TROUBLESHOOTING INFORMATION (22-BE-003H, 2022/07/08)
- BLIND SPOT DETECTION (BSD) OR BLIND-SPOT COLLISION WARNING (BCW) (19-BE-011H, 2019/05/20)
- BLIND-SPOT COLLISION WARNING (BCW) MODULE REPLACEMENT INFORMATION (19-BE-008H, 2019/05/01)

Blind-Spot Collision Warning (BCW) System - Service Tips (Article 42601)

Blind-Spot Collision Warning (BCW) System	Service Tips (1)
<p>Circuit Description</p> <p>Blind Spot Collision Warning System operates BCW (Blind Spot Collision Warning), LCA (Lane Change Assist) functions by providing an alert when a vehicle has entered a blind spot to the rear or side of the vehicle.</p> <p>Blind Spot Collision Warning System assists drivers by providing information (Visual, auditory) measuring the distance and speed of a rear vehicle using two radars installed on the left and right backside of the vehicle.</p> <p>■ Rear And Side Warning Radar (BCW & LCA)</p> <p>BCW radar is Phase Mono-Pulse type of FMCW(Frequency Modulation Continuous Wave). ECU and sensors are integrated module.</p> <p>1. BCW & LCA control sequence</p> <ol style="list-style-type: none"> 1) Driver controls BCW switch. (ON / OFF) 2) BCW & LCA sensor detects rear and side of the vehicle. <ul style="list-style-type: none"> - Calculates position and velocity of rear vehicle using current vehicle's speed signal and y w sensor. (Rear vehicle speed, distance, acceleration/ deceleration, and current road curvature) 3) Alert algorithm <ul style="list-style-type: none"> - Check the alert entry conditions using current vehicle's speed signal and road curvature. - When BCW or LCA warning condition is satisfied, outputs alert. <p>2. Activation conditions of sensors</p> <ol style="list-style-type: none"> 1) BCW Switch : Switch ON (LED Illuminates) 2) Speed : Faster than 30km/h. 3) Change of curvature : Longer than 170m. <p>3. Deactivation conditions of sensors.</p> <ol style="list-style-type: none"> 1) BCW Switch : Switch OFF. (LED Illuminates) 2) Speed : Slower than 30km/h. 3) Change of curvature : Shorter than 150m. 4) Overtaking speed faster than 15km/h. 	<p>4. Prohibition conditions of BCW System</p> <ol style="list-style-type: none"> 1) When front of radar is covered with obstacles. (System status - blockage) message output 2) When location of radar mounted is distorted by external shocks. (Fault code sent) 3) BCW & LCA system failure. (fault code sent) 4) Radar overheating. (the system state - over temperature) message output <p>■ LCA System mode operation</p> <ol style="list-style-type: none"> 1. When start engine with switch in OFF, LCA system is OFF mode. 2. When press the ON switch from OFF mode, LCA system goes to passive mode. 3. When start engine with switch in ON, LCA system is passive mode. 4. While driving, if activation conditions (Speed, Change of curvature) is satisfied, LCA system mode changes from passive to active mode. (alert ON) 5. While driving, if activation conditions (Speed, Change of curvature) is not satisfied, LCA system goes to passive mode. (alert OFF) 6. When LCA system is malfunction in any mode, LCA system mode changes to failure mode. 7. When LCA system operates normally in failure mode, LCA system mode changes to OFF mode. 8. When OFF switch is pressed while LCA system in Active/Passive mode, LCA system mode changes to OFF mode. <p>■ Sensor Alignment</p> <p>Sensor's recognizing direction must be in aligned with drive direction of vehicle to operate normally.</p> <p>BCW sensor alignment is matching direction of the vehicle with sensor.</p> <p>Without performing BCW sensor alignment, it may causes false alarm or system malfunction due to poor detection performance.</p> <p>■ Auto-alignments must be done for bumper accident vehicle.</p>

Blind-Spot Collision Warning (BCW) System	Service Tips (2)																																							
<p>■ Diagnosis</p> <p>Diagnosis of BCW radar is performed only when vehicle speed faster than 7km/h with BCW switch is ON.</p> <p>If you check the wiring and connectors of radar, it is composed of power (IG1, Ground), communication (CAN-High, CAN-Low), outputs (Switch, left/right LED). Thus, main failure of system is internal fault, malfunction of power, circuit and communication.</p> <p>■ DTC Code and Actions</p> <table border="1"> <thead> <tr> <th>DTC</th> <th>Description</th> <th>Actions</th> </tr> </thead> <tbody> <tr> <td>C1101</td> <td>Battery power high</td> <td>Check battery, charger, cables, connectors</td> </tr> <tr> <td>C1102</td> <td>Battery power low</td> <td>Check battery, charger, cables, connectors</td> </tr> <tr> <td>C1616</td> <td>CAN communication line malfunction</td> <td>Check cables, connectors</td> </tr> <tr> <td>C160A</td> <td>Private CAN communication line malfunction</td> <td>Check cables, connectors</td> </tr> <tr> <td>C170A</td> <td>Switch LED circuit malfunction</td> <td>Check switch circuit short to ground</td> </tr> <tr> <td>C1501</td> <td>Switch malfunction</td> <td>Check push status of the switch</td> </tr> <tr> <td>C170C</td> <td>Right sensor ECU hardware malfunction</td> <td>Replace right side radar sensor</td> </tr> <tr> <td>C170D</td> <td>Left sensor ECU hardware malfunction</td> <td>Replace left side radar sensor</td> </tr> <tr> <td>C2702</td> <td>Right sensor Missing calibration</td> <td>Check mounting angle of the right side radar sensor</td> </tr> <tr> <td>C2703</td> <td>Left sensor Missing calibration</td> <td>Check mounting angle of the left side radar sensor</td> </tr> <tr> <td>-</td> <td>Blockage</td> <td>Check contamination of sensing element</td> </tr> <tr> <td>-</td> <td>high temperature</td> <td>Check contamination of sensing element</td> </tr> </tbody> </table>	DTC	Description	Actions	C1101	Battery power high	Check battery, charger, cables, connectors	C1102	Battery power low	Check battery, charger, cables, connectors	C1616	CAN communication line malfunction	Check cables, connectors	C160A	Private CAN communication line malfunction	Check cables, connectors	C170A	Switch LED circuit malfunction	Check switch circuit short to ground	C1501	Switch malfunction	Check push status of the switch	C170C	Right sensor ECU hardware malfunction	Replace right side radar sensor	C170D	Left sensor ECU hardware malfunction	Replace left side radar sensor	C2702	Right sensor Missing calibration	Check mounting angle of the right side radar sensor	C2703	Left sensor Missing calibration	Check mounting angle of the left side radar sensor	-	Blockage	Check contamination of sensing element	-	high temperature	Check contamination of sensing element	
DTC	Description	Actions																																						
C1101	Battery power high	Check battery, charger, cables, connectors																																						
C1102	Battery power low	Check battery, charger, cables, connectors																																						
C1616	CAN communication line malfunction	Check cables, connectors																																						
C160A	Private CAN communication line malfunction	Check cables, connectors																																						
C170A	Switch LED circuit malfunction	Check switch circuit short to ground																																						
C1501	Switch malfunction	Check push status of the switch																																						
C170C	Right sensor ECU hardware malfunction	Replace right side radar sensor																																						
C170D	Left sensor ECU hardware malfunction	Replace left side radar sensor																																						
C2702	Right sensor Missing calibration	Check mounting angle of the right side radar sensor																																						
C2703	Left sensor Missing calibration	Check mounting angle of the left side radar sensor																																						
-	Blockage	Check contamination of sensing element																																						
-	high temperature	Check contamination of sensing element																																						

Erratic Operation (itype_132)

Tsbs

- BLIND SPOT DETECTION (BSD) OR BLIND-SPOT COLLISION WARNING (BCW) (19-BE-011H, 2019/05/20)

Poor performance (itype_162)

Tsbs

- BLIND-SPOT RADAR REPLACEMENT, AND MOUNTING ANGLE VALIDATION (19-BE-016H, 2019/10/14)
- BLIND SPOT DETECTION (BSD) OR BLIND-SPOT COLLISION WARNING (BCW) (19-BE-011H, 2019/05/20)

OEM Policies and Procedures (itype_120)

Tsbs

- BLIND SPOT DETECTION (BSD) OR BLIND-SPOT COLLISION WARNING (BCW) (19-BE-011H-1, 2019/11/04)
- BLIND-SPOT COLLISION WARNING (BCW) MODULE REPLACEMENT INFORMATION (19-BE-008H, 2019/05/01)