

# **Component Procedures: Windows and Glass**

## **Table of Contents**

1. Parts and Labor (itype\_189)
2. Power Window System - w/ IMS - Schematic Diagrams (Article 42541)
3. Power Window System - w/o IMS - Schematic Diagrams (Article 42540)

# Component Procedures: Windows and Glass

## Parts and Labor (itype\_189)

### Parts

Qualifier	Part #	Name	Price	Note
Rear Door > Window Motor	83450F2000	Left	114.08	
Rear Door > Window Motor	83460F2000	Right	142.65	
Rear Door > Window Regulator	83471F3000	Left	776.53	
Rear Door > Window Regulator	83481F3000	Right	776.53	
Rear Door > Window Regulator?	83471F2000	Korea Built	390.66	
Rear Door > Window Regulator?	83471F3000	Us Built	776.53	
Rear Door > Window Regulator?	83481F2000	Korea Built	390.66	
Rear Door > Window Regulator?	83481F3000	Us Built	776.53	
Rear Door > Window Switch	93580F21004X	Window Switch	152.84	
Rear Door > Window Switch > ?	93580F24104X	With Heated Seats	124.11	
Rear Door > Window Switch > ?	93575F21004X	Without Heated Seats	112.32	
Rear Door > Window Switch > ?	93580F25104X	With Heated Seats	126.76	
Rear Door > Window Switch > ?	93575F20104X	Without Heated Seats	77.69	
Front Door > Window Motor	82460F2000	Right	295.87	
Front Door > Window Motor > ?	82450F2010	With Auto Up/down	307.16	
Front Door > Window Motor > ?	82450F2010	With Auto Up/down & Sa?	307.16	
Front Door > Window Motor > ?	82450F2000	Without Auto Up/down	307.16	
Front Door > Window Motor > ?	82450F2000	Without Auto Up/down & ?	307.16	
Front Door > Window Regulator	82471F3030	Left	566.40	
Front Door > Window Regulator	82481F3030	Right	566.40	
Front Door > Window Regulator?	82471F2030	Korea Built	267.98	
Front Door > Window Regulator?	82471F3030	Us Built	566.40	
Front Door > Window Regulator?	82481F2030	Korea Built	267.98	
Front Door > Window Regulator?	82481F3030	Us Built	566.40	
Front Door > Window Switch > ?	93571F30104X	With Memory	333.76	Order By Vehicle Applicati?
Front Door > Window Switch > ?	93570F21004X	Without Memory	199.03	Order By Vehicle Applicati?
Front Door > Window Switch > ?	93575F34004X	With Memory	289.08	Order By Vehicle Applicati?
Front Door > Window Switch > ?	93575F20004X	Without Memory	77.69	Order By Vehicle Applicati?

### Labor

Operation	Qualifier Path	Skill	Std Hrs	Wty Hrs
Remove & Replace	Front Door > Window Motor, R&R > One Side	B	0.6	0.0
Remove & Replace	Front Door > Window Regulator, R&R > One Side	B	1.6	0.0
Remove & Replace	Front Door > Window Switch, R&R > One	B	0.5	0.0
Remove & Replace	Rear Door > Window Motor, R&R > One Side	B	0.7	0.0
Remove & Replace	Rear Door > Window Regulator, R&R > One Side	B	1.6	0.0
Remove & Replace	Rear Door > Window Switch, R&R > One Side	B	0.5	0.0

## Power Window System - w/ IMS - Schematic Diagrams (Article 42541)

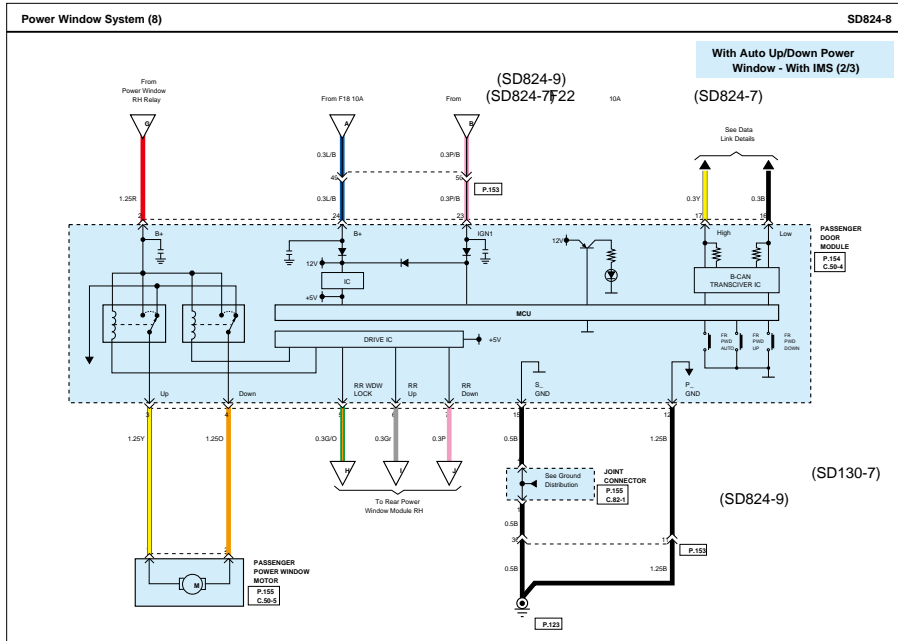
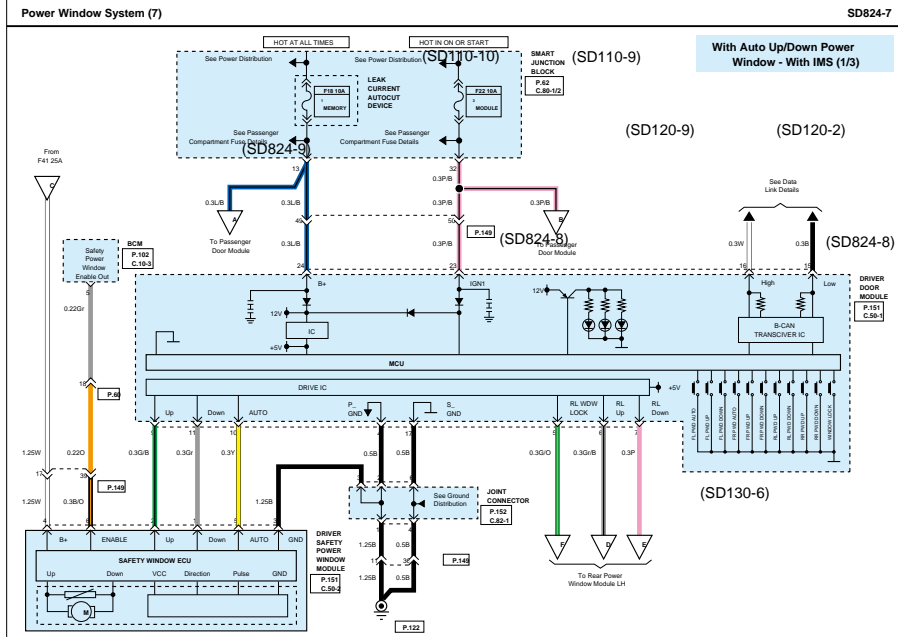





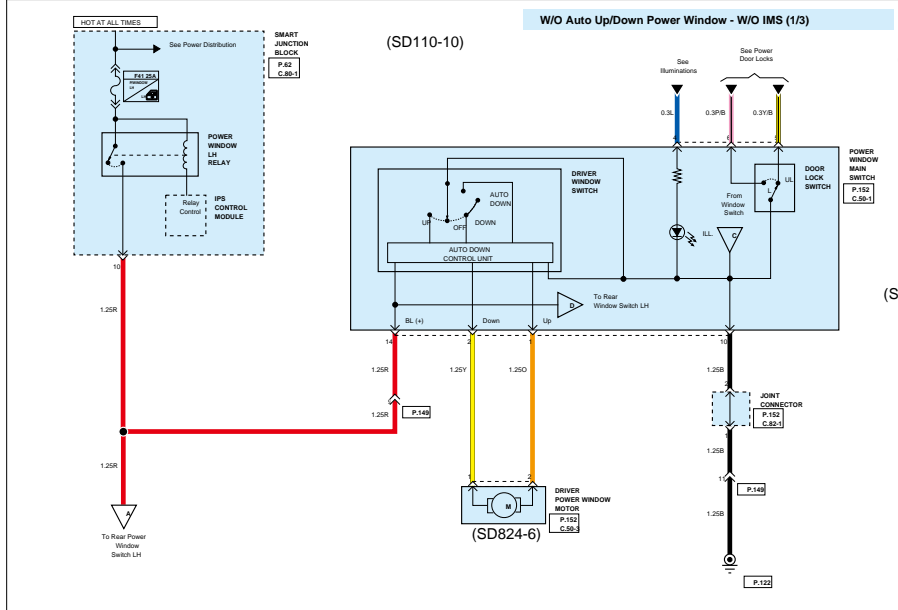

(SD941-2) (SD813-1)

(SD824-5)

(SD824-6)

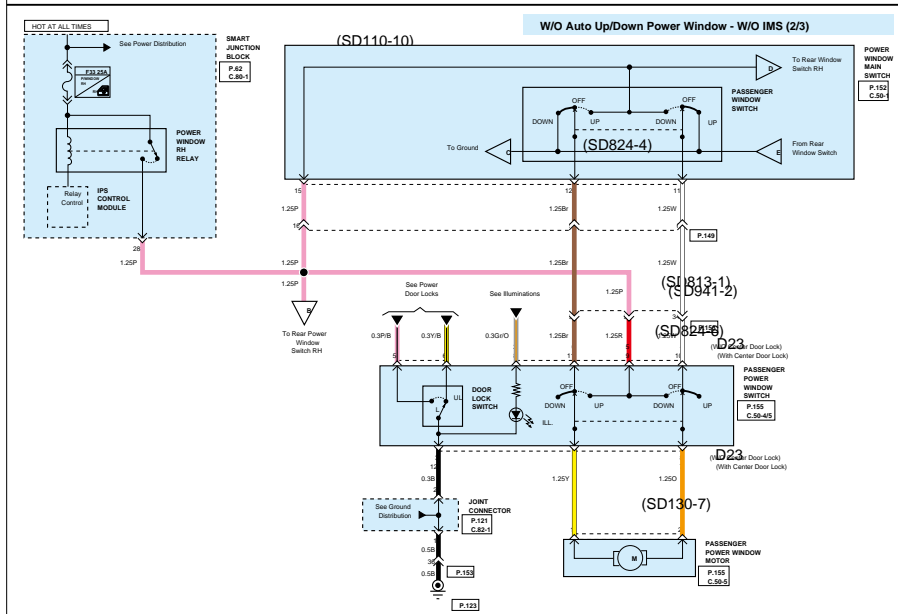

(SD824-6)

(SD824-6)

D23C

D23C

W/O Auto Up/Down Power Window - W/O IMS (3/3)

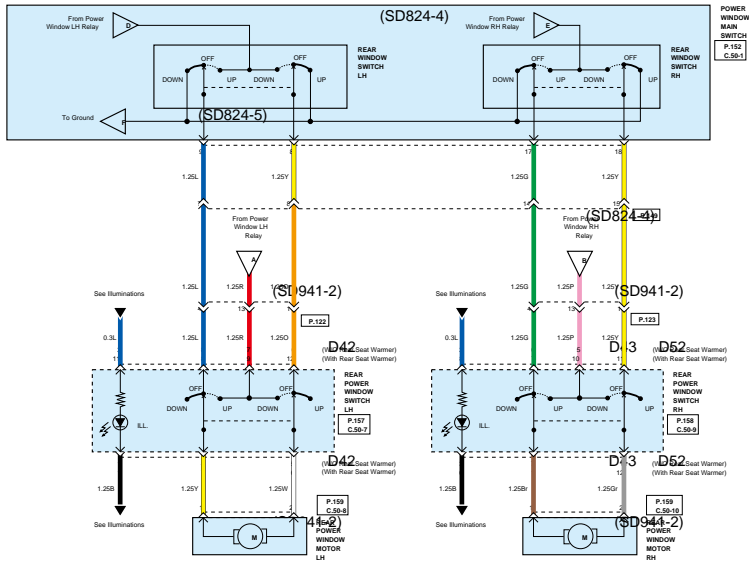

(SD824-5)

(SD824-5)

D53

D53