

Component Procedures: Tires

Table of Contents

1. Parts and Labor (itype_189)
2. Tire - Repair Procedures (Article 44290)
3. All New Technical Service Bulletins (itype_432)
4. All Technical Service Bulletins (itype_100)
5. Vibration (itype_176)
6. OEM Policies and Procedures (itype_120)
7. Tools and Equipment (itype_113)

Component Procedures: Tires

Parts and Labor (itype_189)

Labor

Operation	Qualifier Path	Skill	Std Hrs	Wty Hrs
Remove & Replace	Chassis & Wheels > Wheels, R&R > Each	C	0.5	0.0
Balance	Chassis & Wheels > Wheels, Balance > One	C	0.3	0.0
Balance	Chassis & Wheels > Wheels, Balance > Each Add?	C	0.2	0.0
Rotate	Chassis & Wheels > Wheels, Rotate > 4 Wheels	C	0.4	0.0
Rotate	Chassis & Wheels > Wheels, Rotate > 4 Wheels ?		0.1	

Tire - Repair Procedures (Article 44290)

- Tire Wear
- Measure the tread depth of the tires . Tread depth [limit] : 1.6 mm (0.063 in)
- If the remaining tread depth (A) is less than the limit, replace the tire. When the tread depth of the tires is less than 1.6 mm(0.063 in), the wear indicators (B) will appear.
- When the tread depth of the tires is less than 1.6 mm(0.063 in), the wear indicators (B) will appear.

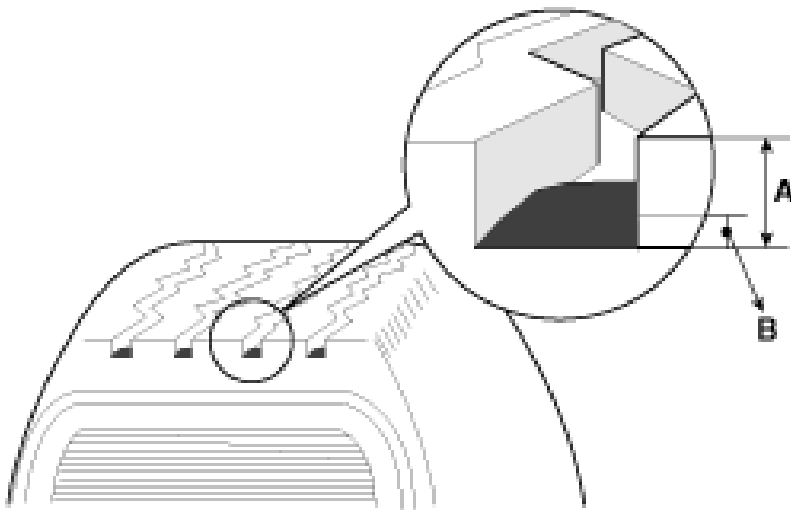

- Removal
- Remove valve core and deflate the tire.
- Remove the side of the tire bead area from the wheel using tire changing machine. The tire bead should be broken approx. 90° from the valve side of the wheel. The bead breaker should not be set too deep. Avoid tire/tool contact with the valve on dismount. Dismount should end near the valve.

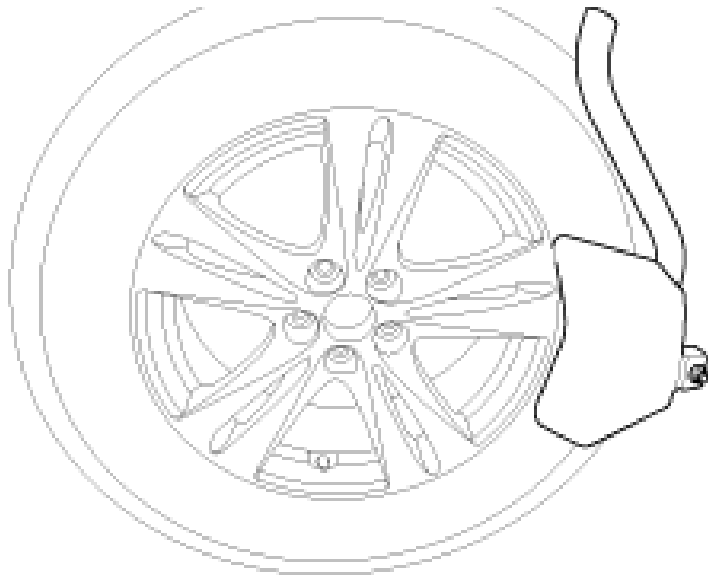

The tire bead should be broken approx. 90° from the valve side of the wheel. The bead breaker should not be set too deep. Avoid tire/tool contact with the valve on dismount. Dismount should end near the valve.

- The tire bead should be broken approx. 90° from the valve side of the wheel. The bead breaker should not be set too deep.
- Avoid tire/tool contact with the valve on dismount.
- Dismount should end near the valve.
- Rotate the wheel clockwise.

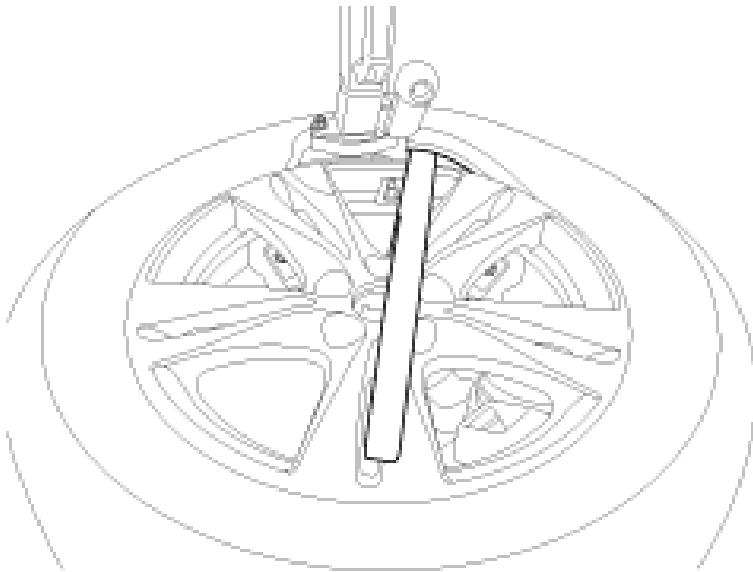



- Installation
- Apply tire soap or lubrication to the top and bottom tire beads.

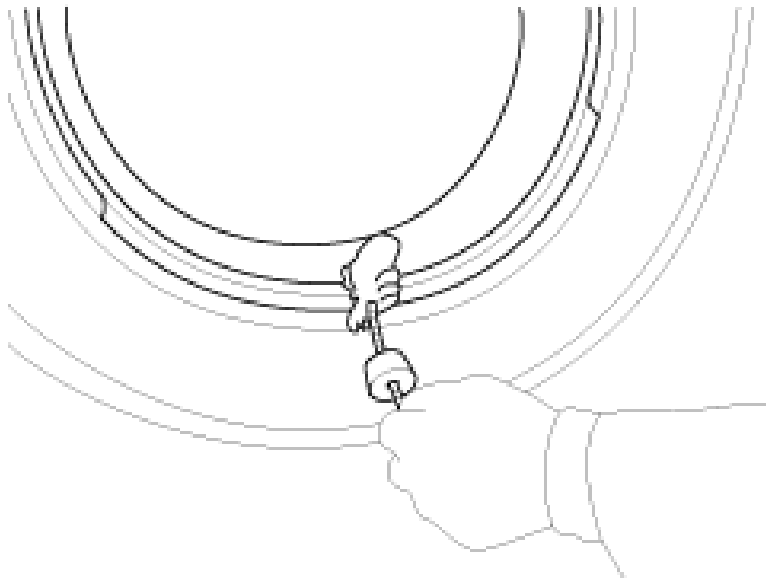

- To fit the bottom bead, position the valve at the 5 o'clock position relative to the head on the tire changing machine.

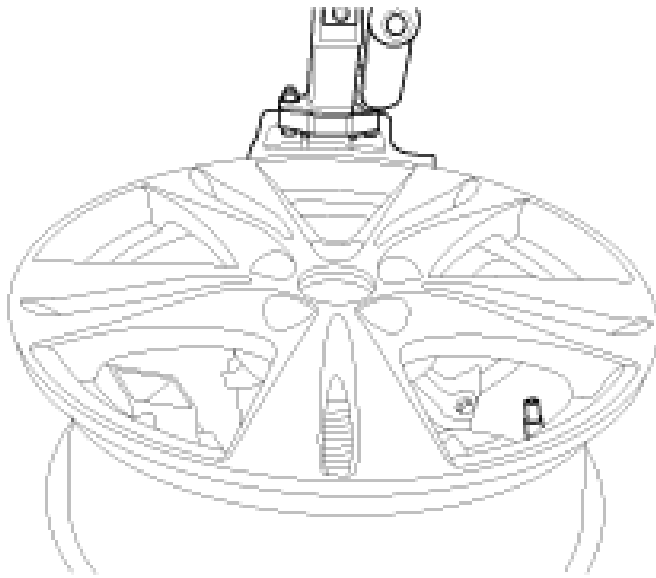

- Place the tire on the rim so the bottom bead touches the edge of the rim after the valve (6 o'clock). Rotate the rim clockwise, and push down on the tire at the 3 o'clock position to fit bottom bead.

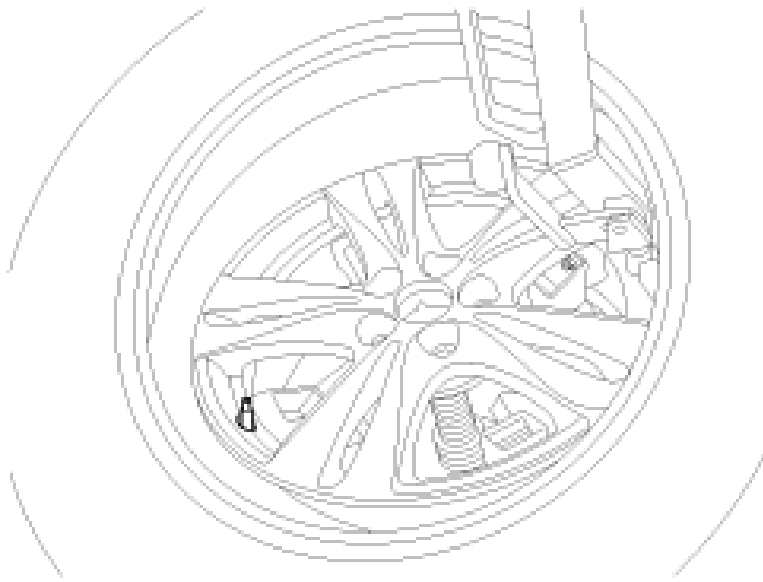

- After bottom bead is on tire, rotate the rim until the valve is at the 5 o'clock position relative to the head on the tire changing machine. Push down on the tire at the 3 o'clock position and rotate the rim clockwise to fit the top bead.

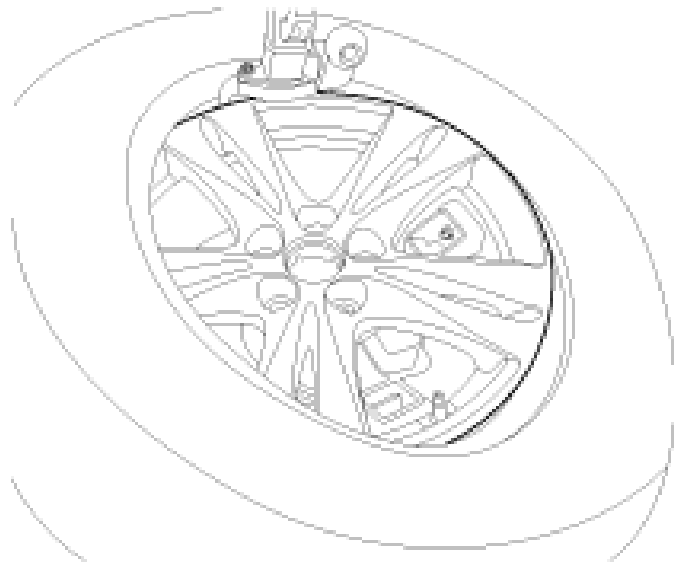

- Inflate the tire until both beads seat. Recommended Tire pressure : 230 kPa (33 psi)

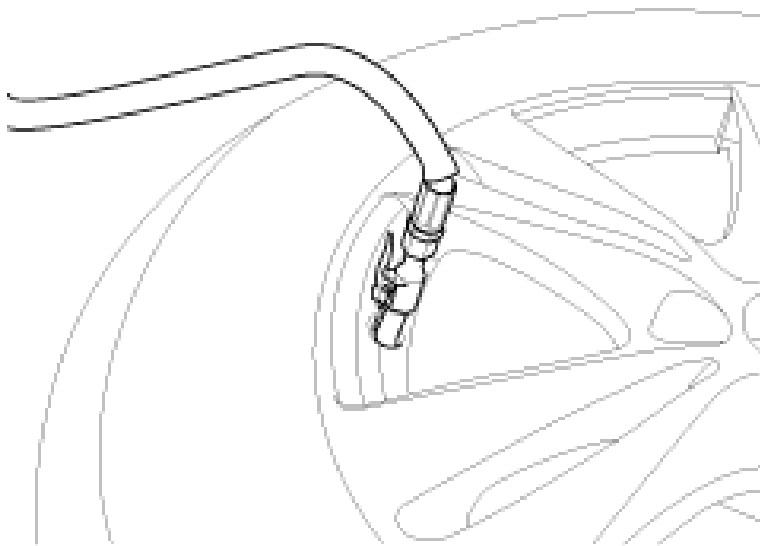

- Adjustment
- Rotate the front right and front left tires, and perform a road test in order to confirm vehicle stability.

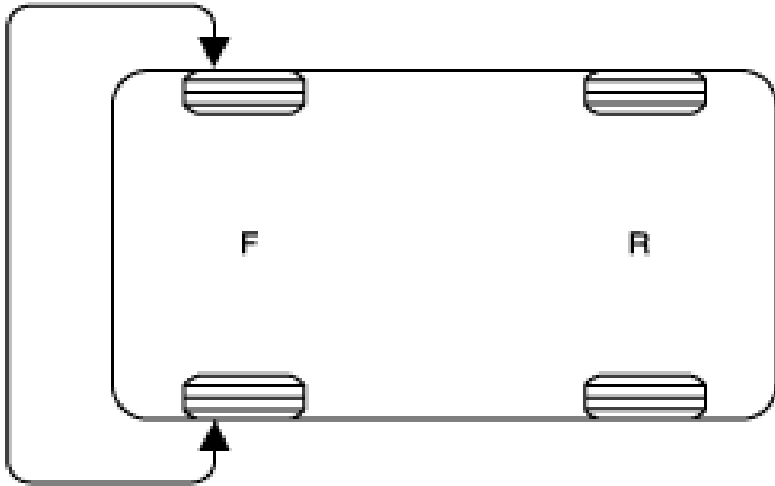

- If the steering pulls to the opposite side, rotate the front and rear tires, and perform a road test again.

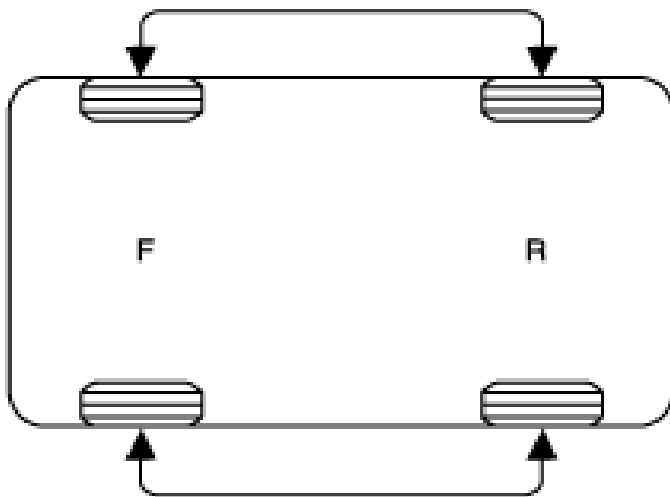

- If the steering continues to pull to one side, rotate the front right and left tires again, and perform a road test.

- If the steering continues to pull to the opposite side, replace the front wheels with new ones.

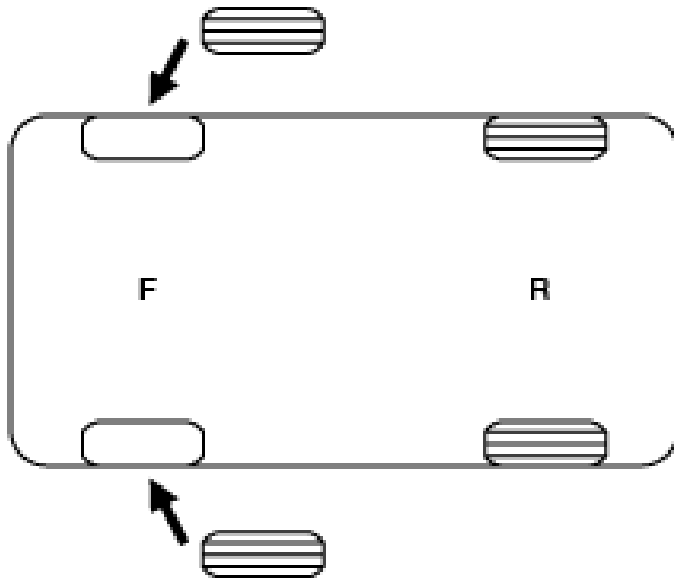

All New Technical Service Bulletins (itype_432)

Tsbs

- WHEEL/TIRE VIBRATION – BALANCE AND RADIAL FORCE VARIATION (RFV) SERVICE PROCEDURES (25-SS-002H-1, 2025/06/30)

All Technical Service Bulletins (itype_100)

Tsbs

- TIRE MAINTENANCE BEST PRACTICES (20-SS-002H, 2020/05/04)
- WHEEL/TIRE VIBRATION – BALANCE AND RADIAL FORCE VARIATION (RFV) SERVICE PROCEDURES (25-SS-002H-1, 2025/06/30)

Vibration (itype_176)

Tsbs

- WHEEL/TIRE VIBRATION – BALANCE AND RADIAL FORCE VARIATION (RFV) SERVICE PROCEDURES (25-SS-002H-1, 2025/06/30)

OEM Policies and Procedures (itype_120)

Tsbs

- TIRE MAINTENANCE BEST PRACTICES (20-SS-002H, 2020/05/04)

Tools and Equipment (itype_113)

Tsbs

- WHEEL/TIRE VIBRATION – BALANCE AND RADIAL FORCE VARIATION (RFV) SERVICE PROCEDURES (25-SS-002H-1, 2025/06/30)