

# **Component Procedures: Wheel Hub**

## **Table of Contents**

1. Parts and Labor (itype\_189)
2. Specifications Quick Reference (itype\_439)
3. Front Hub / Knuckle - Components and Components Location (Article 45290)
4. Rear Hub / Carrier - Components and Components Location (Article 45301)
5. Front Hub / Knuckle - Repair Procedures (Article 45292)
6. Rear Hub / Carrier - Repair Procedures (Article 45302)

# Component Procedures: Wheel Hub

## Parts and Labor (itype\_189)

### Parts

Qualifier	Part #	Name	Price	Note
Torsion Axle > Rear Suspensi?	52730F2000	3 - Hub & Bearing Asse?	866.18	
Front Suspension > Suspensio?	51750F2000	1 - Front Hub	478.77	
Multi Link > Rear Suspension?	52730G2000	2 - Hub & Bearing Asse?	866.18	

### Labor

Operation	Qualifier Path	Skill	Std Hrs	Wty Hrs
Remove & Replace	Front Suspension > Suspension Components > Fr?	B	2.1	0.0
Remove & Replace	Front Suspension > Suspension Components > Fr?	B	4.0	0.0
Remove & Replace	Multi Link > Rear Suspension > Suspension Com?	B	1.2	0.0
Remove & Replace	Multi Link > Rear Suspension > Suspension Com?	B	2.1	0.0
Remove & Replace	Torsion Axle > Rear Suspension > Suspension C?	B	1.2	0.0
Remove & Replace	Torsion Axle > Rear Suspension > Suspension C?	B	2.1	0.0

## Specifications Quick Reference (itype\_439)

### Quick Specifications

- item

## Front Hub / Knuckle - Components and Components Location (Article 45290)

- Components

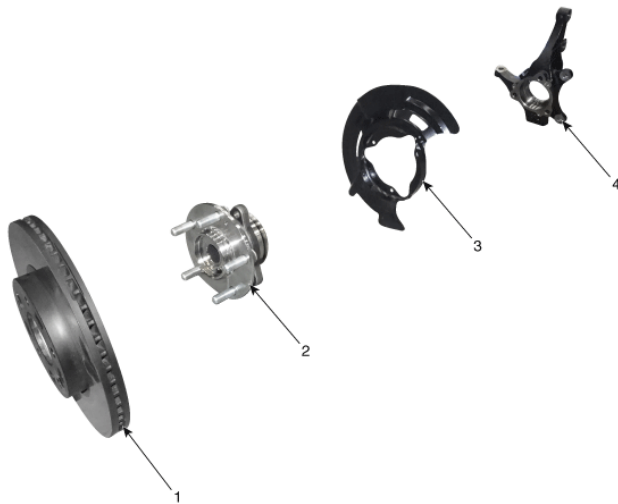

1. Brake disc 2. Hub bearing 3. Dust cover 4. Knuckle

## Rear Hub / Carrier - Components and Components Location (Article 45301)

- Components

[Disc type]



1. Rear brake disc 2. Rear hub bearing 3. Backing plate 4. Bracket  
[Drum type]

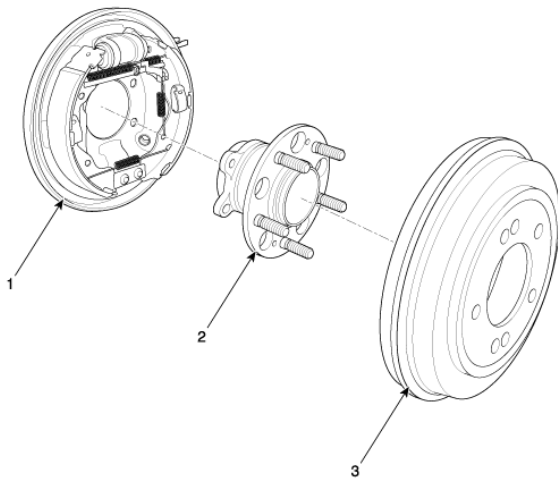

1. Rear brake assembly 2. Hub & bearing assembly 3. Rear brake drum

### Front Hub / Knuckle - Repair Procedures (Article 45292)

- Removal
- Loosen the wheel nut s slightly. Raise the vehicle, and make sure it is securely supported.
- Remove the front wheel and tire (A) from the front hub . Tightening torque : 107.9 ~ 127.5 N.m (11.0 ~ 13.0 kgf.m, 79.6 ~ 94.0 lb-ft) Be careful not to damage the hub bolt s when removing the front wheel and tire (A).



Be careful not to damage the hub bolts when removing the front wheel and tire (A).

# NOTICE

- Be careful not to damage the hub bolts when removing the front wheel and tire (A).
- Loosen the driveshaft caulking nut (A). The driveshaft lock nut should be replaced with new ones. After installation driveshaft lock nut, stake the lock nut using a chisel and hammer as shown in the illustration below. Caulking depth : 1.5 mm (0.591 in.)

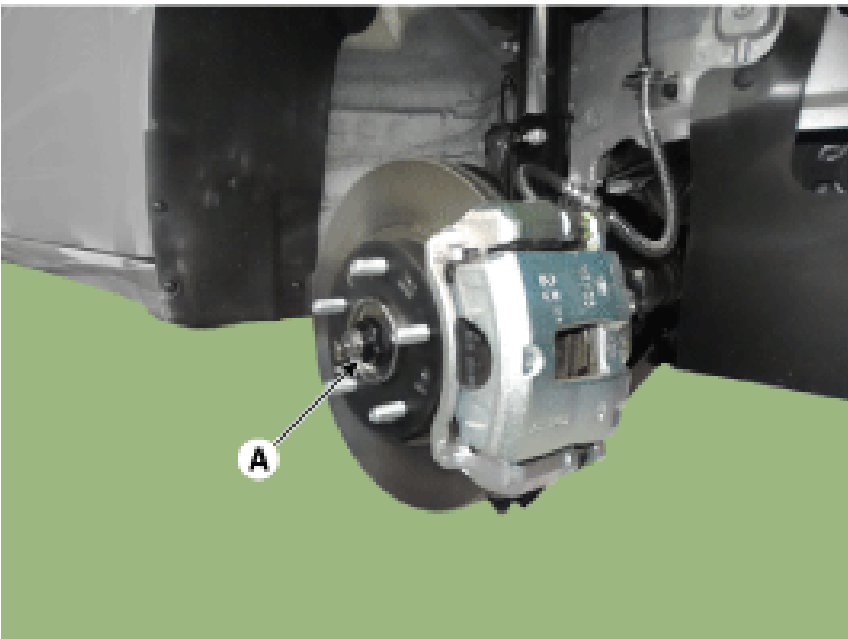

The driveshaft lock nut should be replaced with new ones. After installation driveshaft lock nut, stake the lock nut using a chisel and hammer as shown in the illustration below. Caulking depth : 1.5 mm (0.591 in.)

- The driveshaft lock nut should be replaced with new ones.

- After installation driveshaft lock nut, stake the lock nut using a chisel and hammer as shown in the illustration below. Caulking depth : 1.5 mm (0.591 in.)

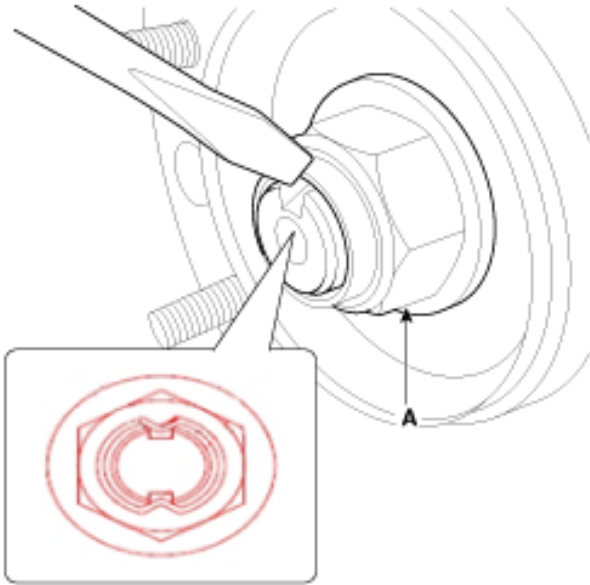

- Loosen the brake hose mounting bolt and then remove the brake hose bracket. Tightening torque : 8.8 ~ 13.7 N.m (0.9 ~ 1.4 kgf.m, 6.5 ~ 10.1 lb-ft)

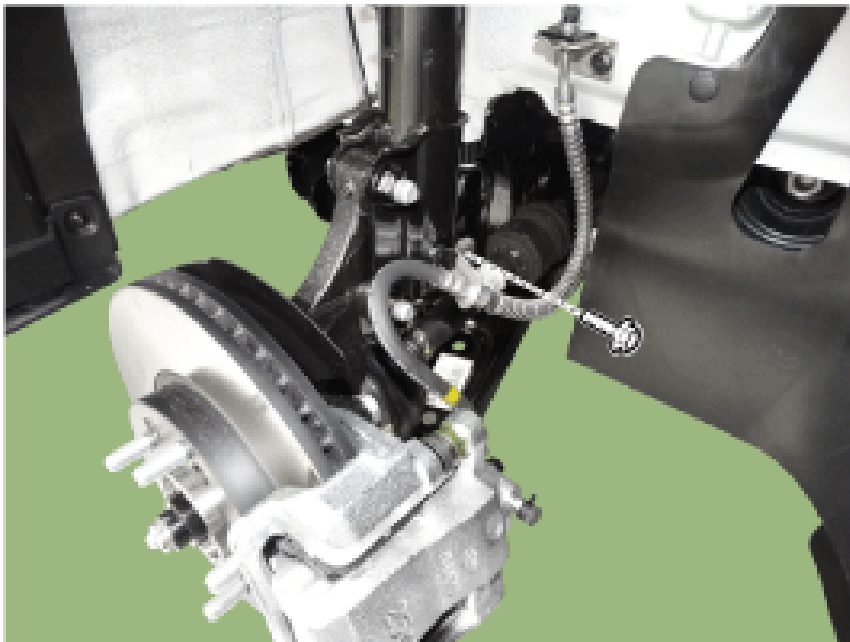

- Put down the caliper body by loosening the guided rod bolt. Tightening torque : 2.2 ~ 3.2 kgf.m

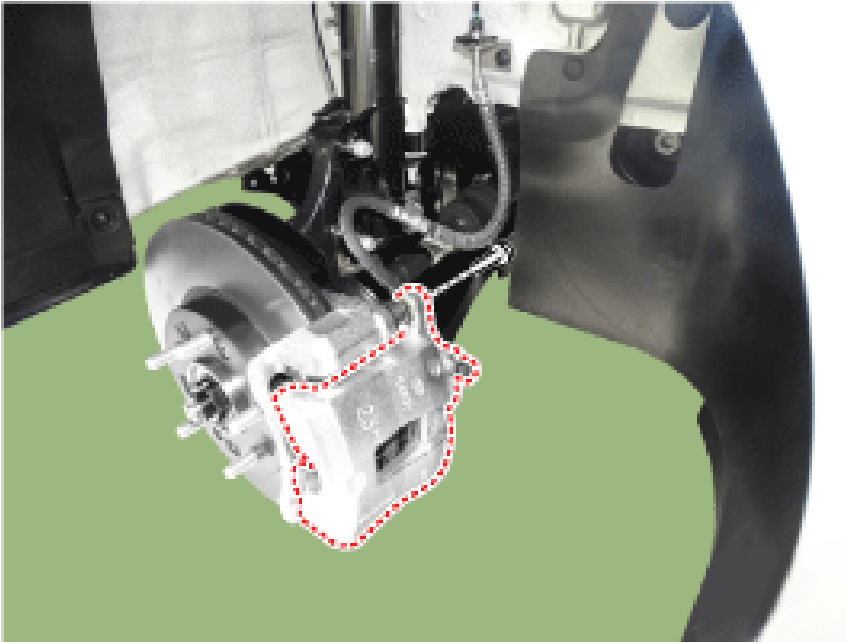

- Remove the pad return spring (A). Pad return springs must be replaced with new ones whenever pads are replaced. Technicians should be careful not to deform pad return springs. When pad return springs are deformed, it may cause improper braking, more fuel consumption.

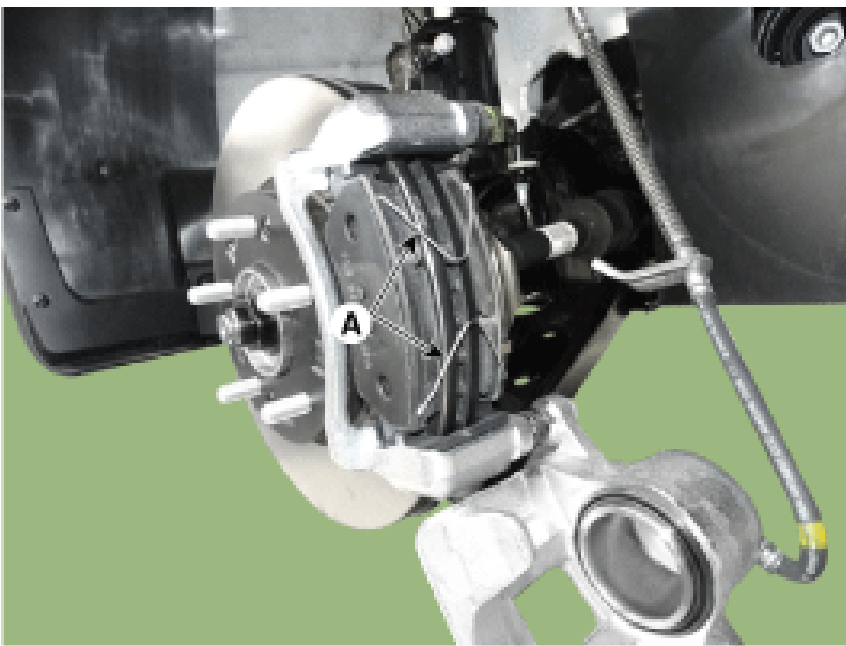

Pad return springs must be replaced with new ones whenever pads are replaced. Technicians should be careful not to deform pad return springs. When pad return springs are deformed, it may cause improper braking, more fuel consumption.

- Pad return springs must be replaced with new ones whenever pads are replaced.
- Technicians should be careful not to deform pad return springs.
- When pad return springs are deformed, it may cause improper braking, more fuel consumption.
- Remove the brake pad.

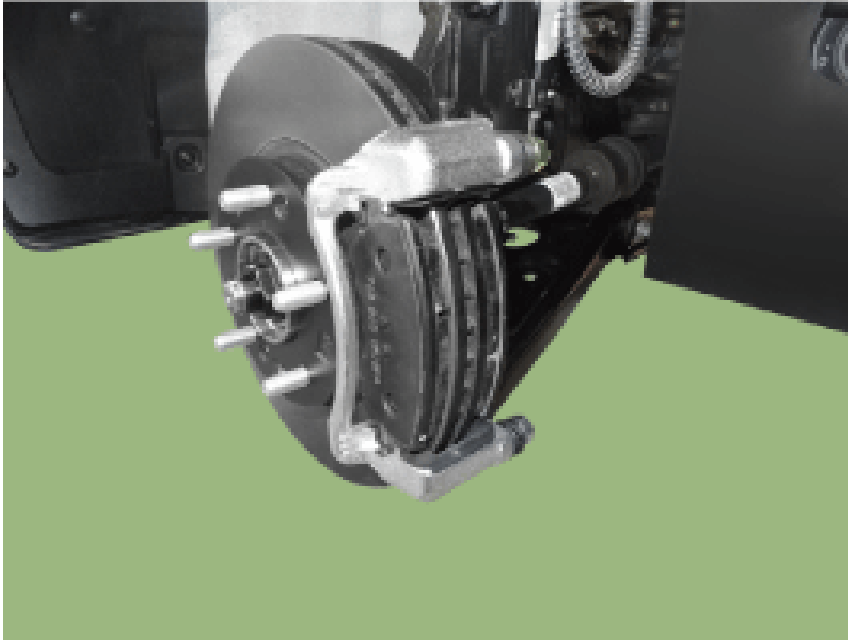

- Separate the pad retainer. And remove the caliper carrier by loosening the caliper mounting bolts.  
Tightening torque : 78.5 ~ 98.1 N.m (8.0 ~ 10.0 kgf.m, 57.9 ~ 72.3 lb-ft)

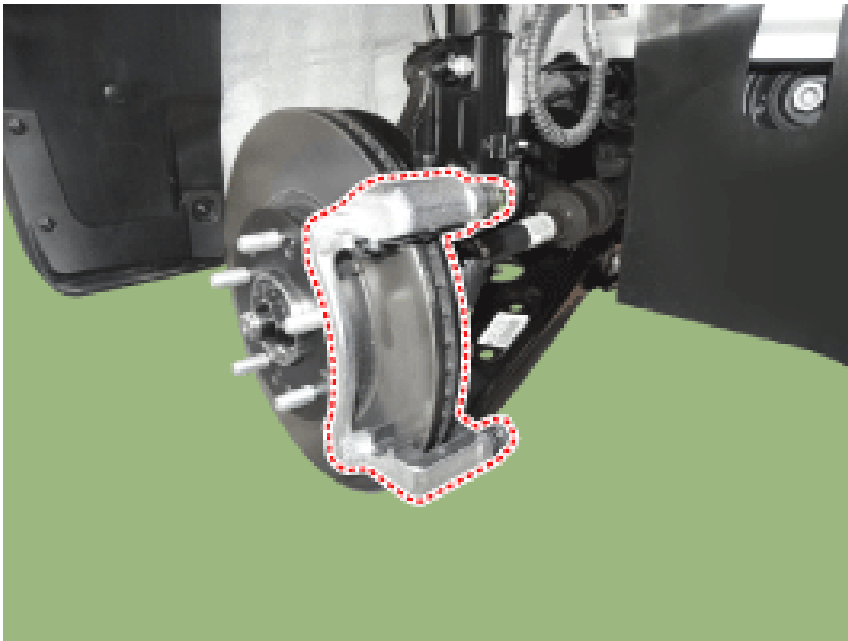

- Remove the tie rod end ball joint . Rmove the split pin (C). Loosen the nut (B). Using SST(09568-1S100), separate the ball joint (A) from the knuckle . Tightening torque : 23.5 ~ 33.3 N.m (2.4 ~ 3.4 kgf.m, 17.4 ~ 24.6 lb-ft)  
- Rmove the split pin (C).  
- Loosen the nut (B).  
- Using SST(09568-1S100), separate the ball joint (A) from the knuckle . Tightening torque : 23.5 ~ 33.3 N.m (2.4 ~ 3.4 kgf.m, 17.4 ~ 24.6 lb-ft)

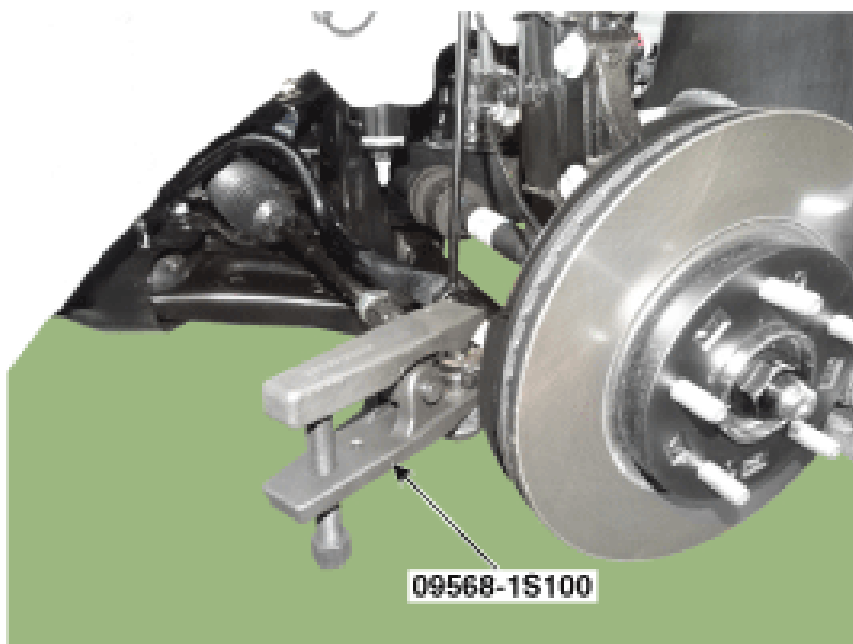
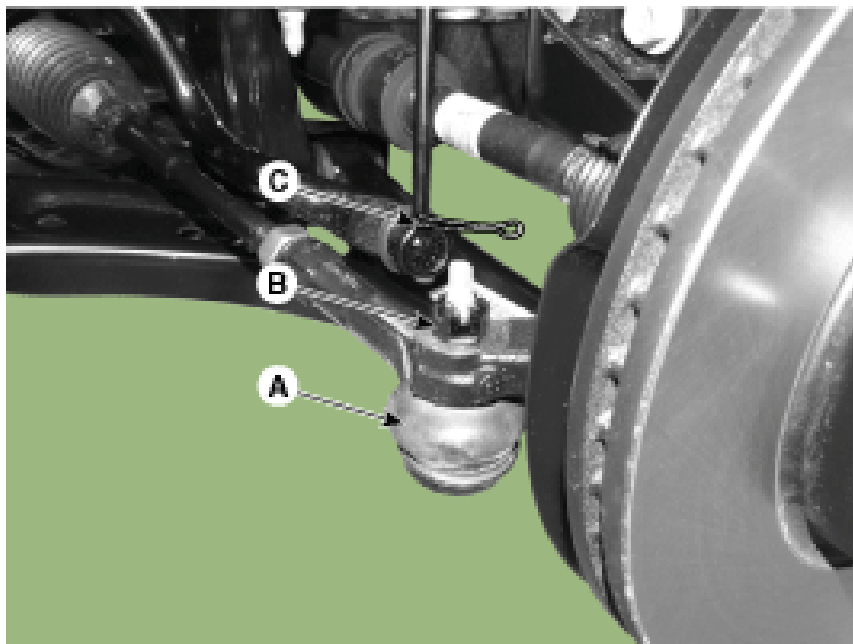

- Loosen the lower arm nut (A) and then remove the lower arm ball joint by using SST(09568-1S100). Tightening torque : 58.8 ~ 70.6 N.m (6.0 ~ 7.2 kgf.m, 43.4 ~ 52.1 lb-ft) Do not reuse the lower arm lock nut(A).

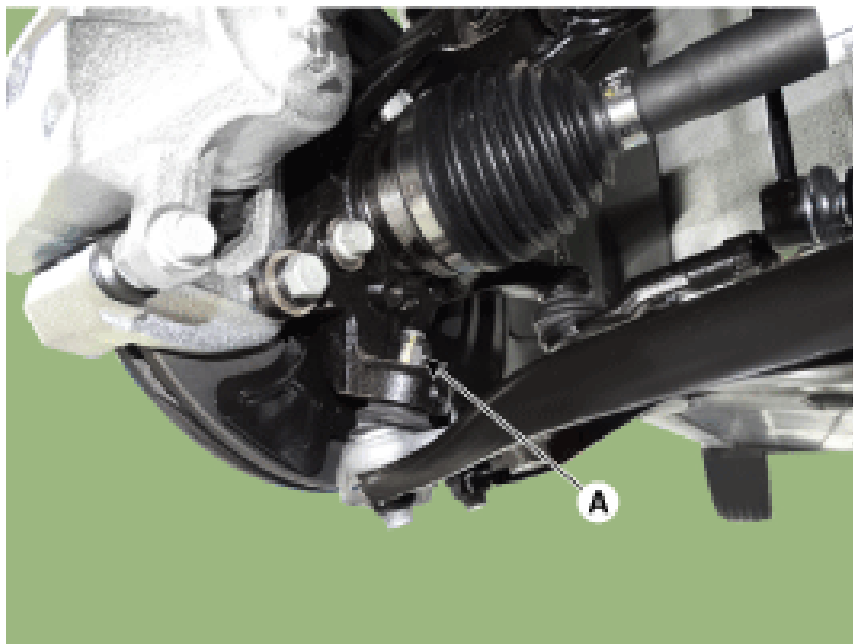

Do not reuse the lower arm lock nut(A).

- Loosen the bolt and then remove the wheel speed sensor (A). Tightening torque : 7.8 ~ 11.8 N.m (0.8 ~ 1.2 kgf.m, 5.8 ~ 8.7 lb-ft)

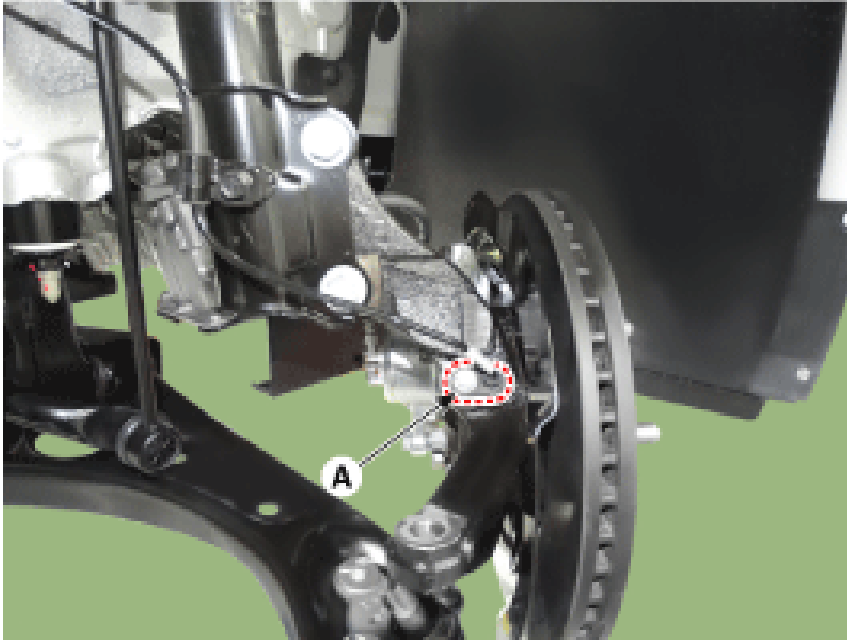

- Loosen the screw and then remove the front disc. Tightening torque : 4.9 ~ 5.9 N.m (0.5 ~ 0.6 kgf.m, 3.6 ~ 4.3 lb-ft)

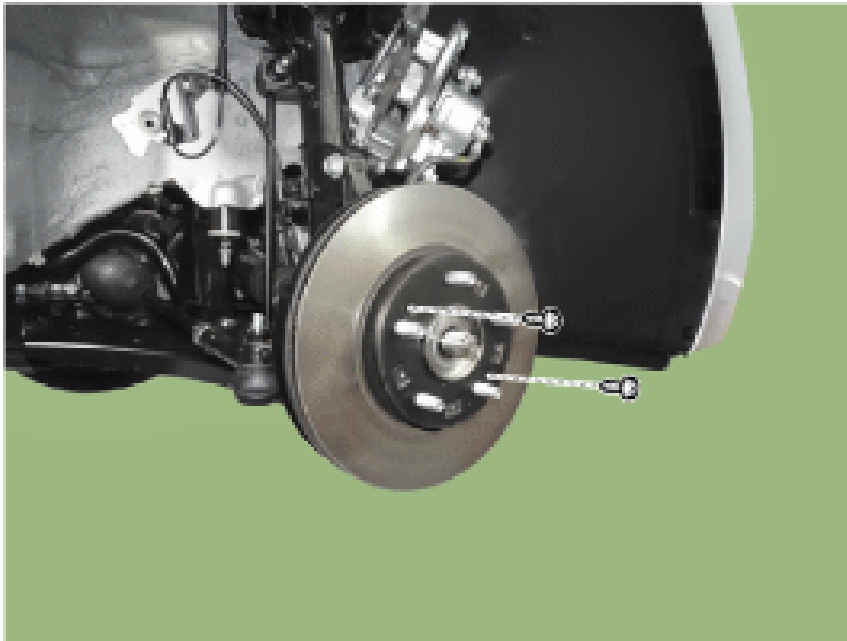

- Loosen the strut mounting bolts (A), nuts (B) and then remove the knuckle assembly (A). Tightening torque : 156.9 ~ 176.5 N.m (16.0 ~ 18.0 kgf.m, 115.7 ~ 130.2 lb-ft)

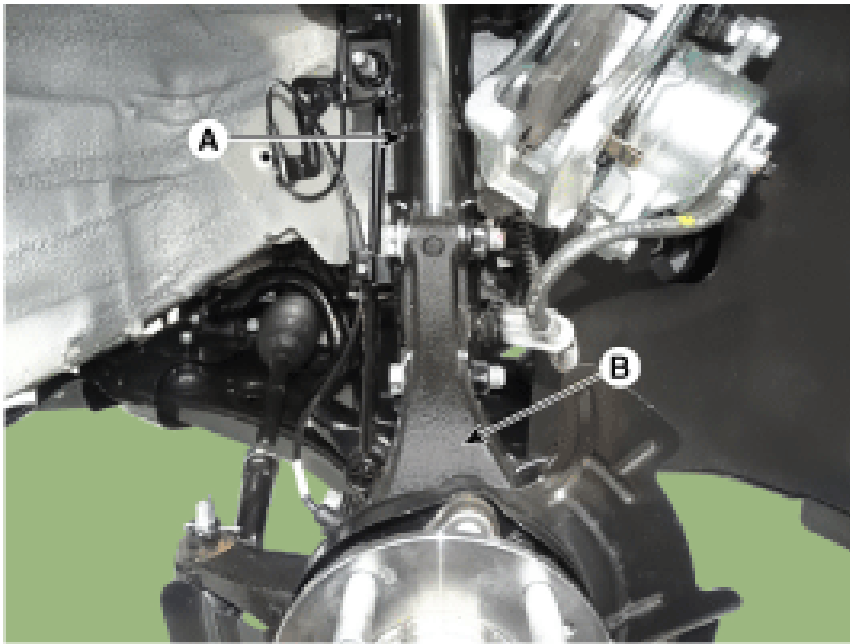

- Install in the reverse order of removal.
- Check the alignment. (Refer to Suspension System - "Alingment")
- Disassembly
- To reassembly, reverse the disassembly procedure. Tightening torque : 49.0 ~ 58.8 N.m (5.0 ~ 6.0 kgf.m, 36.2 ~ 43.4 lb-ft)

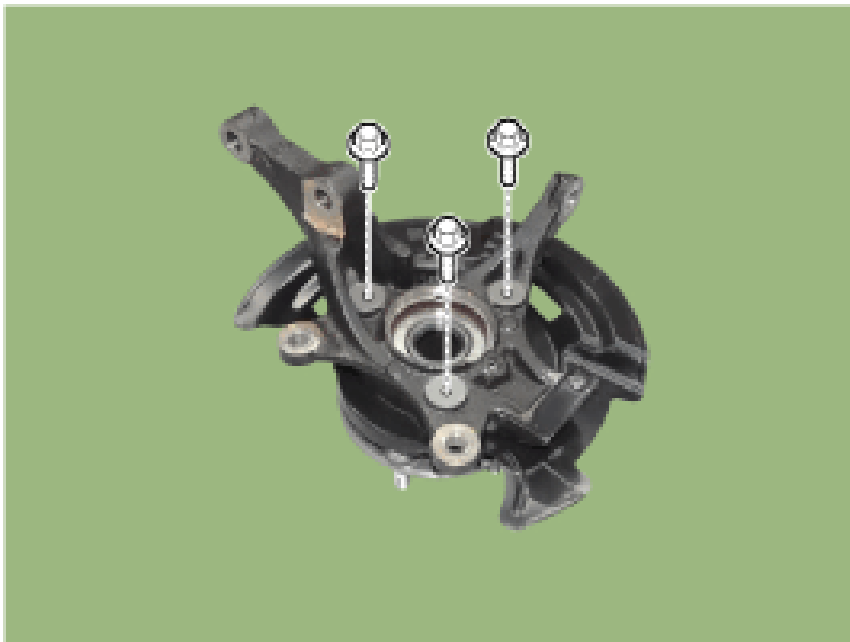

- Loosen the mounting bolts and then remove the dust cover. Tightening torque : 3.9 ~ 5.9 N.m (0.4 ~ 0.6 kgf.m, 2.9 ~ 4.3 lb-ft)

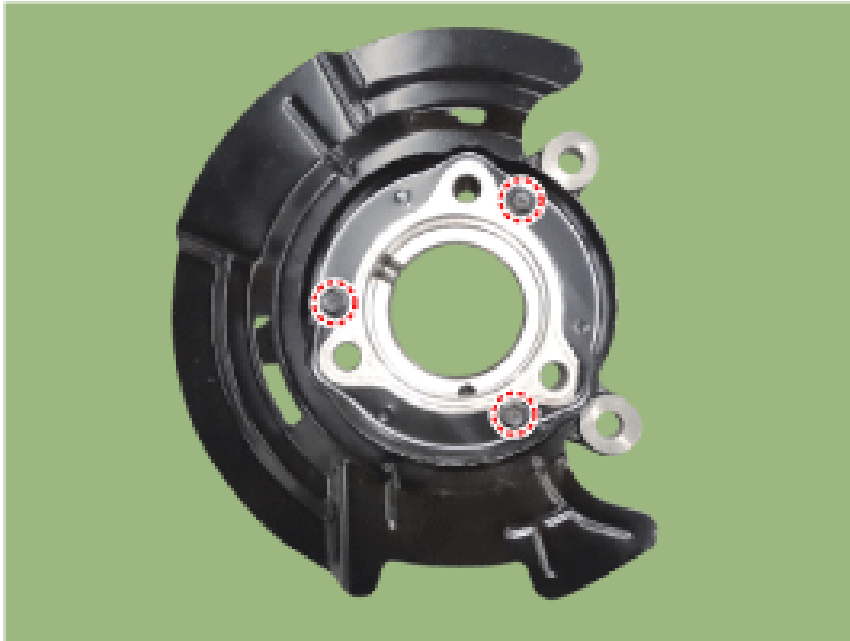

- Reassembly in the reverse order of disassembly.

### Rear Hub / Carrier - Repair Procedures (Article 45302)

- Removal

[Disc type]

- Loosen the wheel nut s slightly. Raise the vehicle, and make sure it is securely supported.

- Remove the rear wheel and tire (A) from front hub . Tightening torque : 107.9 ~ 127.5 N.m (11.0 ~ 13.0 kgf.m, 79.6 ~ 94.0 lb-ft) Be careful not to damage the hub bolt s when removing the rear wheel and tire (A).



Be careful not to damage the hub bolt s when removing the rear wheel and tire (A).

# NOTICE

- Be careful not to damage the hub bolts when removing the rear wheel and tire (A).
- Remove the parking brake cable fixed clip (A).

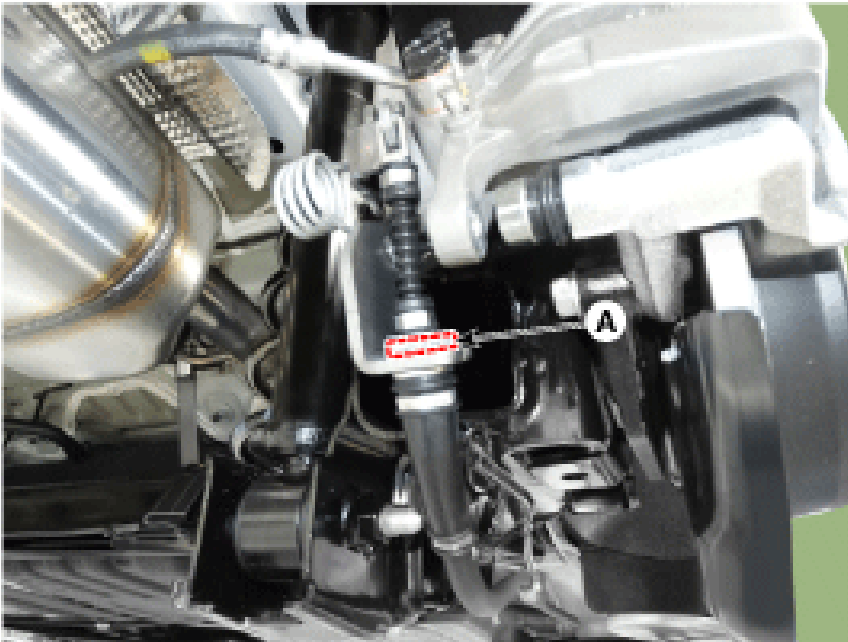

- Remove the rear brake caliper. (Refer to Brake System - "Rear Disc Brake")
- Loosen the screws and then remove the brake disc. Tightening torque : 4.9 ~ 5.9 N.m (0.5 ~ 0.6 kgf.m, 3.6 ~ 4.3 lb-ft)

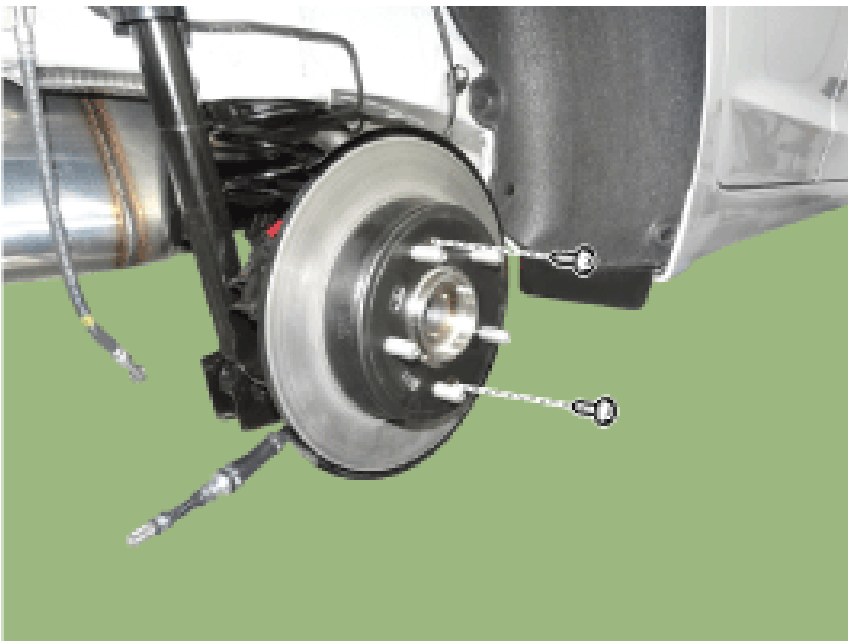

- Disconnect the rear wheel speed sensor connector (A).

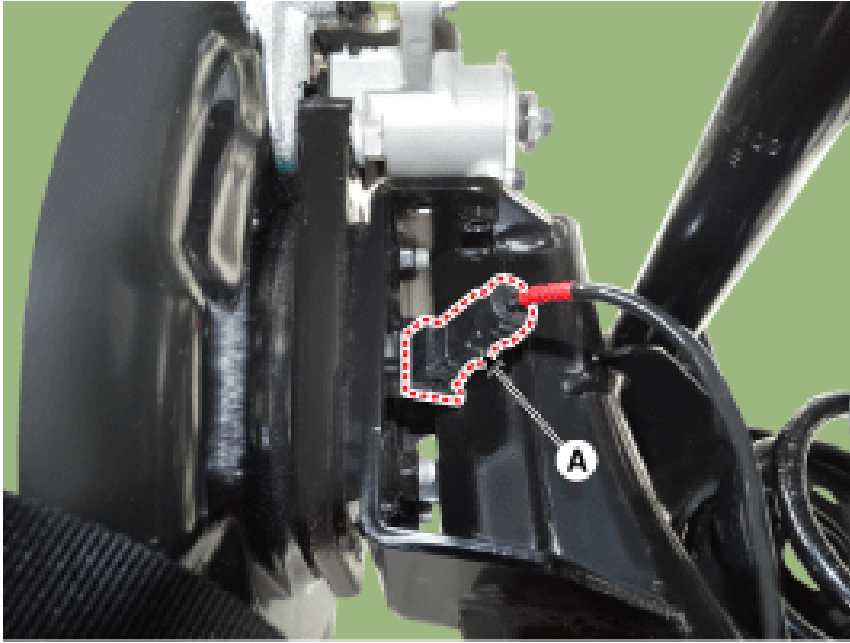

- Loosen the bolts and then remove the hub bearing (A). Tightening torque : 49.0 ~ 58.8 N.m (5.0 ~ 6.0 kgf.m, 36.2 ~ 43.4 lb-ft)

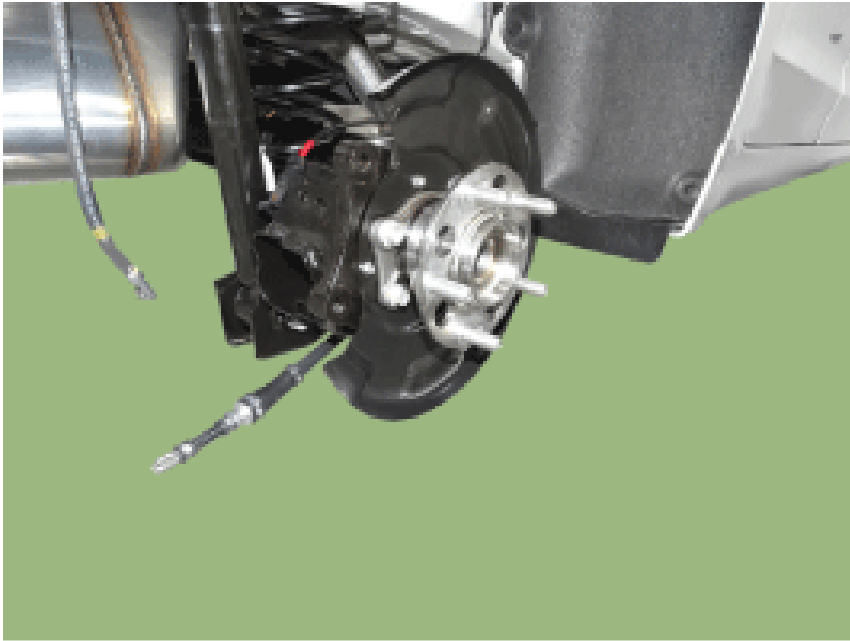



- Install in the reverse order of removal..

[Drum Type]

- Remove the rear wheel & tire (A). Tightening torque : 88.3 ~ 107.9 N.m (9.0 ~ 11.0 kgf.m, 65.1 ~ 79.6 lb-ft)

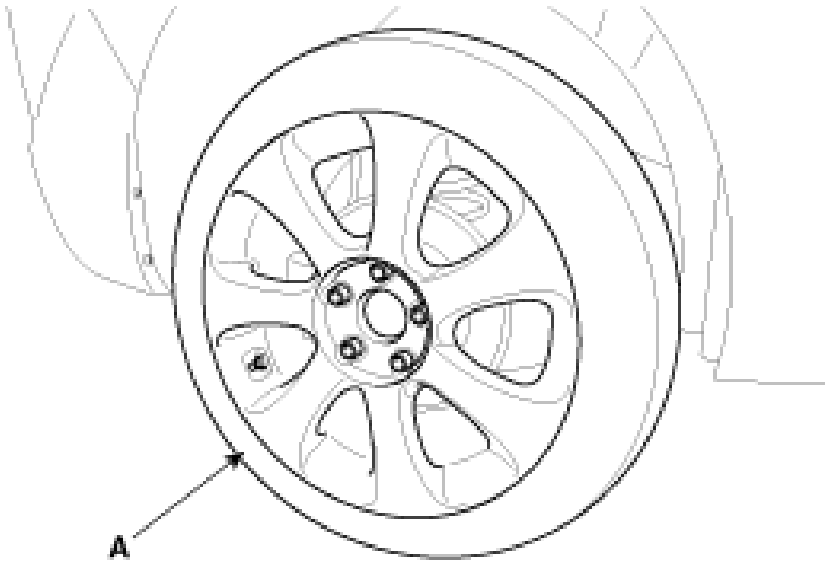

- Disconnect the parking brake clip (A).

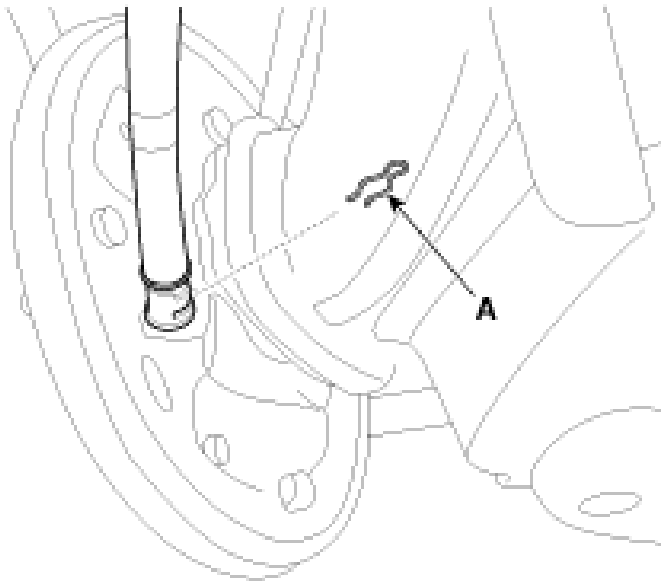

- Loosen the bolt and then remove the parking brake cable (A). Tightening torque : 18.6 ~ 25.5 N.m (1.9 ~ 2.6 kgf.m, 13.7 ~ 18.8 lb-ft)

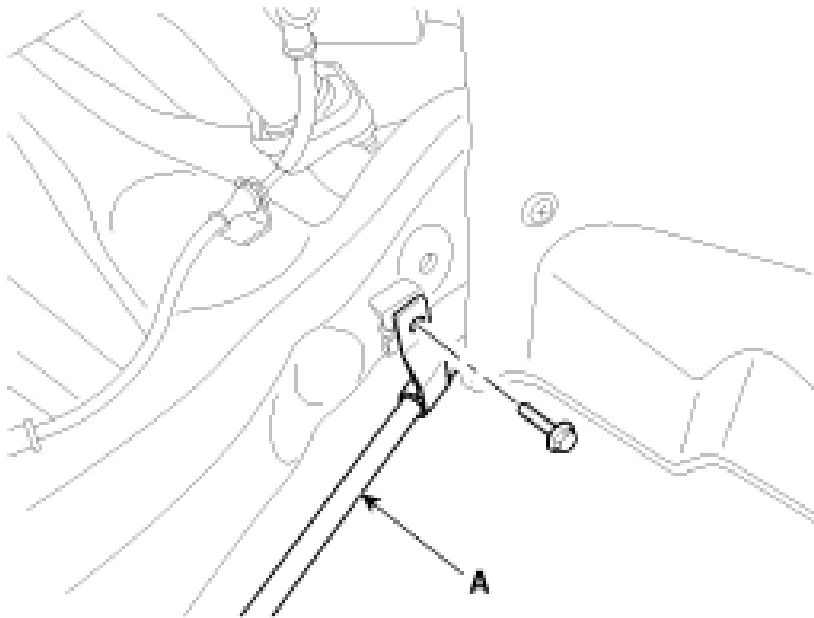

- Loosen the screw (A) and then remove the disc (B). Tightening torque : 4.9 ~ 5.8 N.m (0.5 ~ 0.6 kgf.m, 3.6 ~ 4.3 lb-ft)

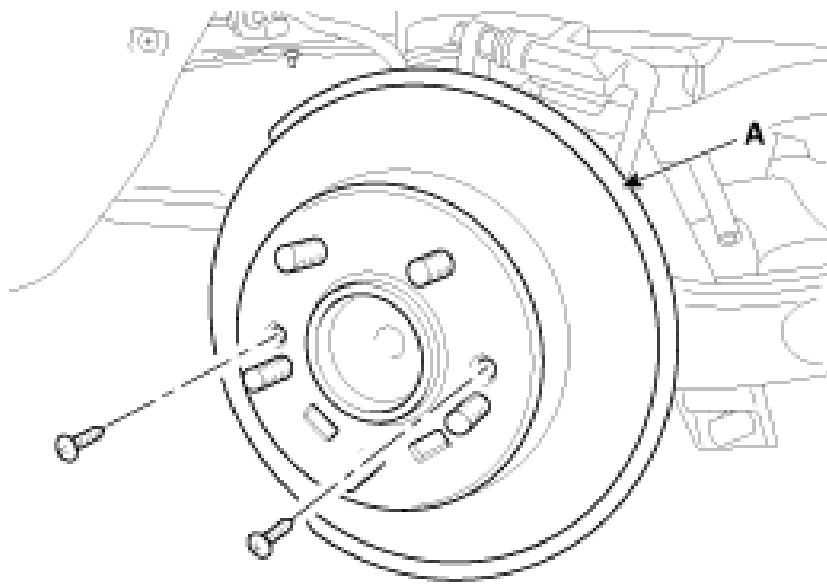

- Remove the spring (A, B, C).

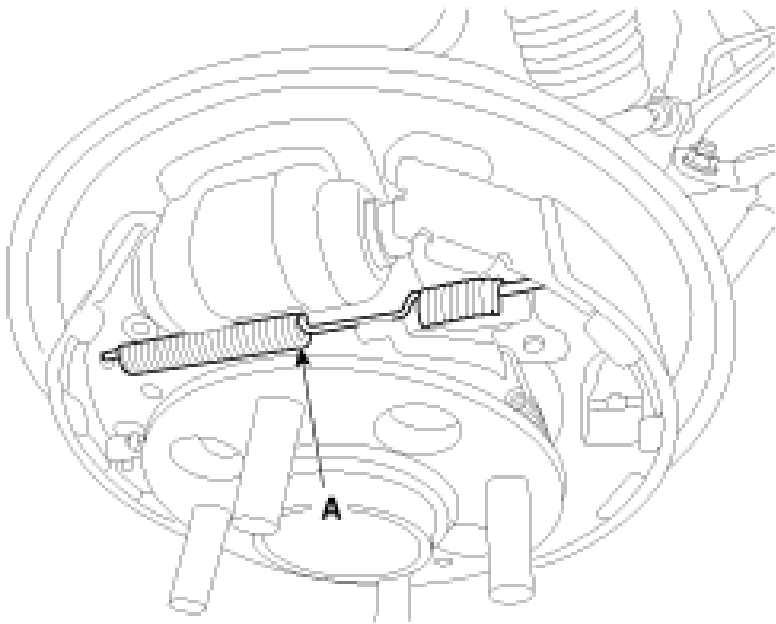

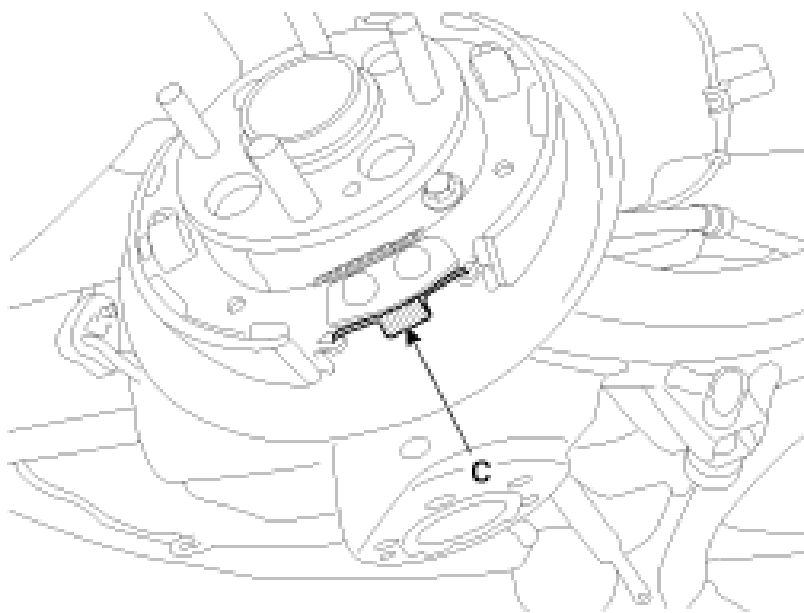
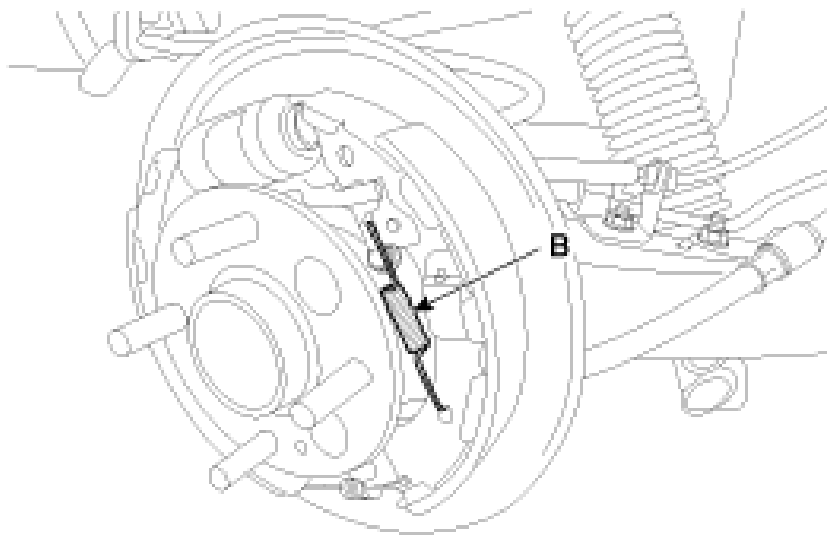

- Remove the shoe (A).

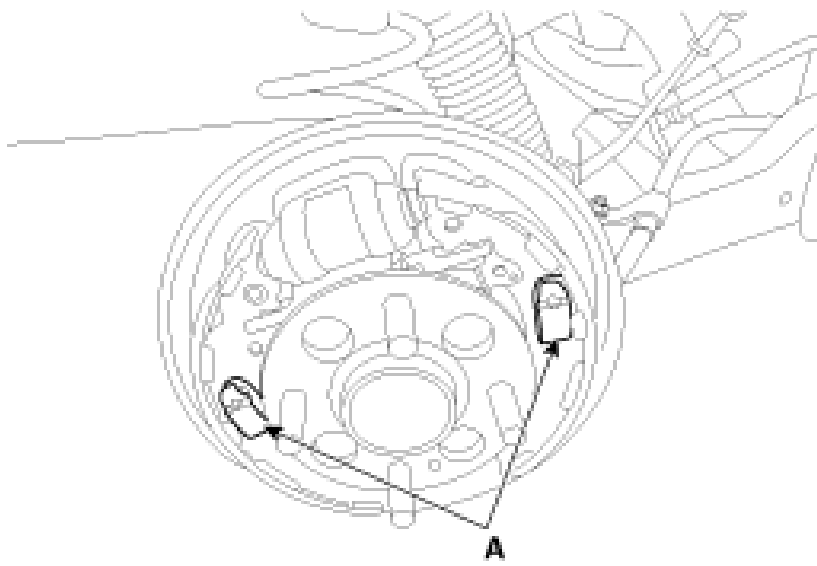

- Disconnect the parking brake cable (A) from lining (B).

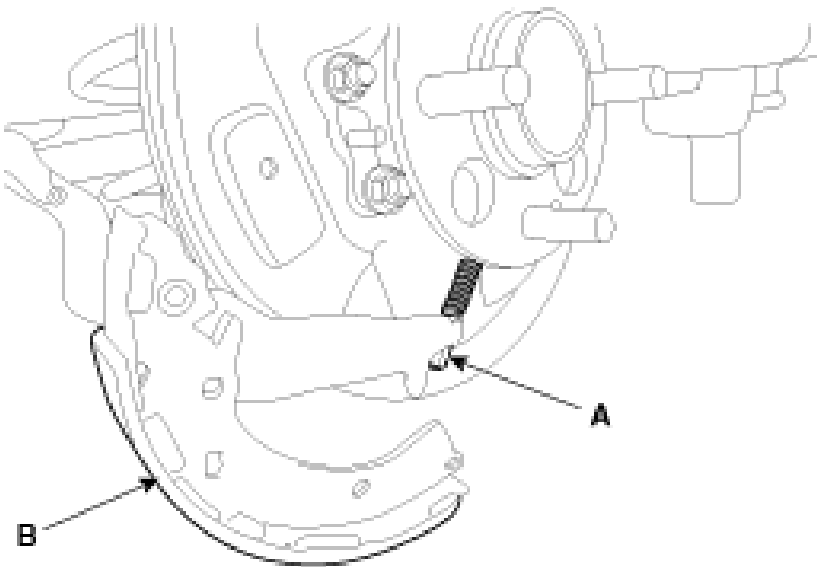

- Remove the brake hose (A) and then loosen the cylinder bolt.

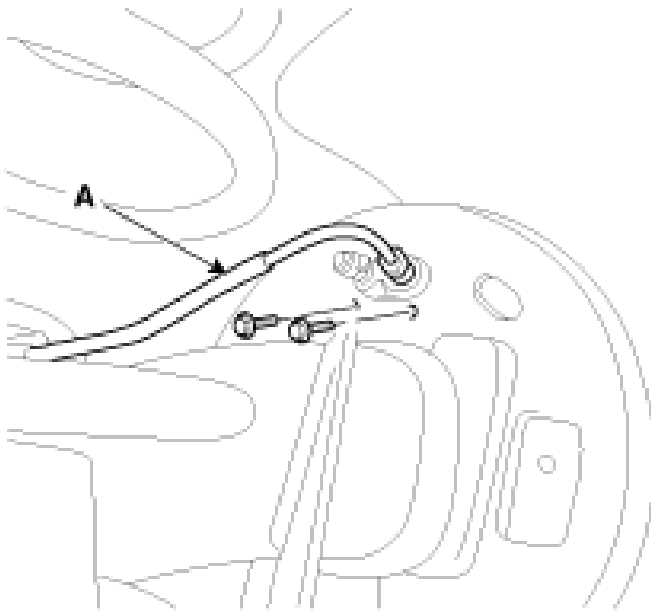

- Loosen the hub mounting bolt and then remove the hub (A) from the torsion beam . Tightening torque : 49.0 ~ 58.8 N.m (5.0 ~ 6.0 kgf.m, 36.2 ~ 43.4 lb-ft)

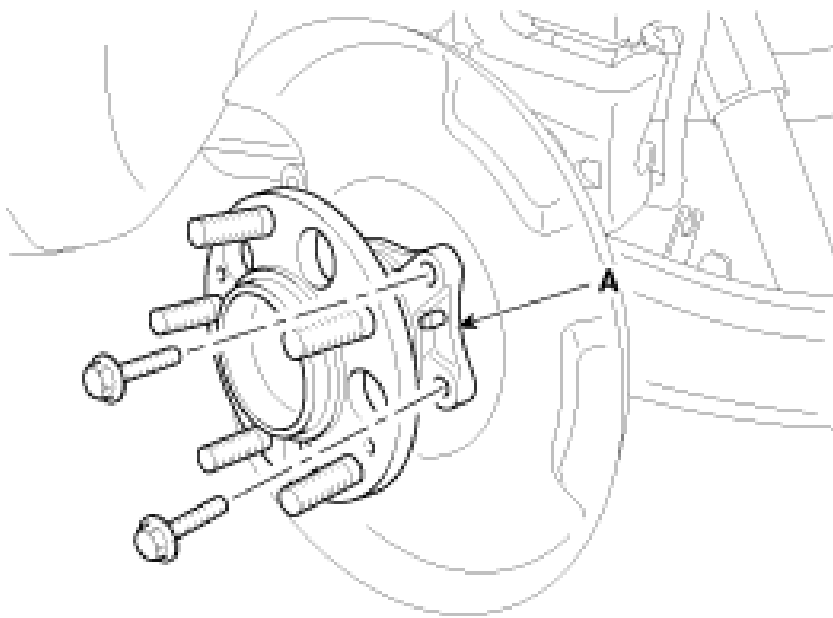

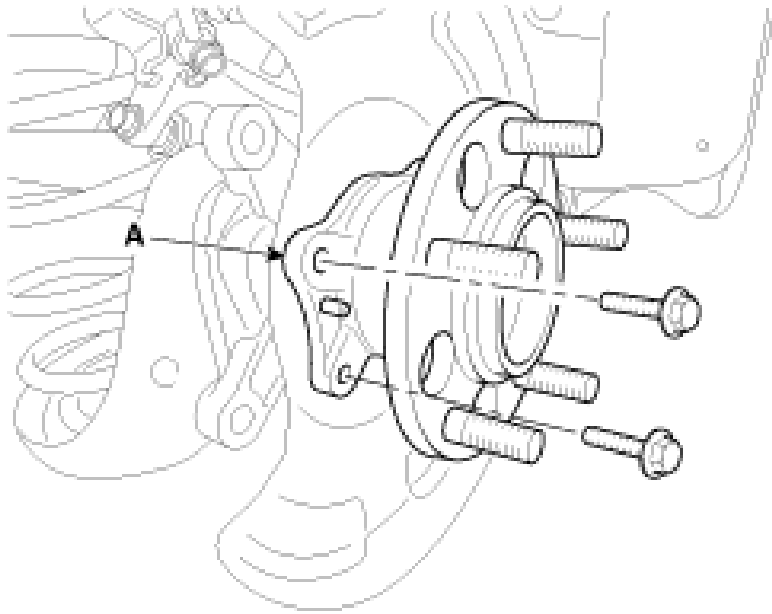

- Inspection
- Check the hub for cracks and the splines for wear.
- Check the brake disc for scoring and damage.
- Check the rear axle carrier for cracks.
- Check the bearing for cracks or damage.
- Replace only the sensor cap when the warning light turns on due to a defective sensor cap of the hub bearing. (Refer to Brake System - "Rear Wheel Speed Sensor")