

Component Procedures: Compressor HVAC

Table of Contents

1. Parts and Labor (itype_189)
2. Compressor - Description and Operation (Article 44846)
3. Compressor - Components and Components Location (Article 44847)
4. Compressor - Repair Procedures (Article 44848)
5. All Technical Service Bulletins (itype_100)

Component Procedures: Compressor HVAC

Parts and Labor (itype_189)

Parts

Qualifier	Part #	Name	Price	Note
Compressor	97701F2100	Compressor	656.24	
Compressor	976433X100	Pulley	207.34	

Labor

Operation	Qualifier Path	Skill	Std Hrs	Wty Hrs
Remove & Replace	Compressor > Clutch, R&R	B	1.8	0.0
Remove & Replace	Compressor > Compressor, R&R	B	1.4	0.0

Compressor - Description and Operation (Article 44846)

- Description

Variable Swash Plate Compressor

ECV Control Diagram

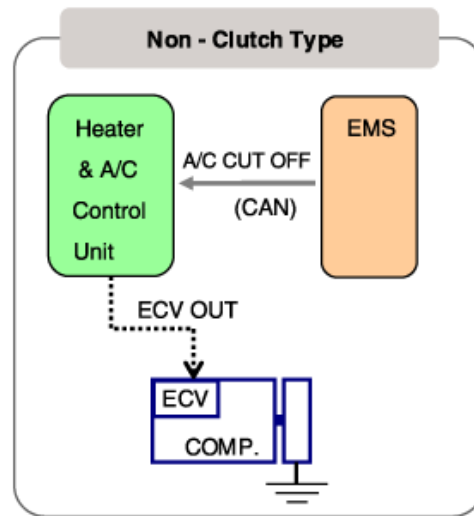

※ Wire :→
CAN : ———→

Compressor - Components and Components Location (Article 44847)

- Components

[Nu Engine]

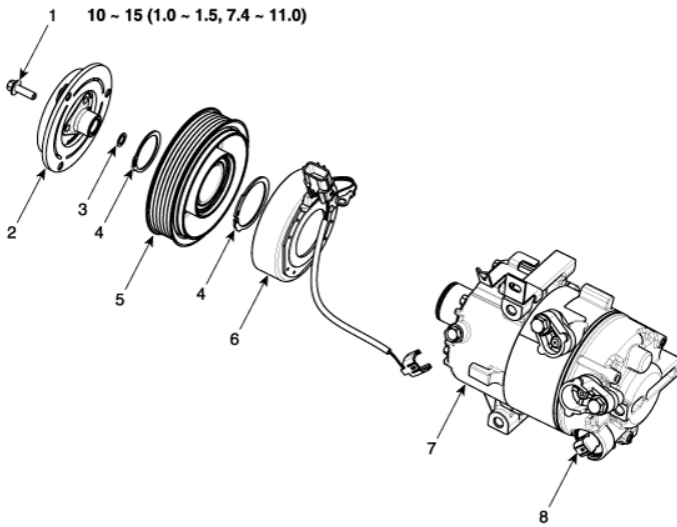

Tightening torque : N.m (kgf.m, lb-ft)

1. Clutch bolt 2. Limiter & Hub Assembly 3. Compressor clutch hub spacer 4. Retainer 5. Pulley 6. Clutch field coil assembly 7. Compressor assembly 8. Electric control valve (ECV)
[Kappa Engine]

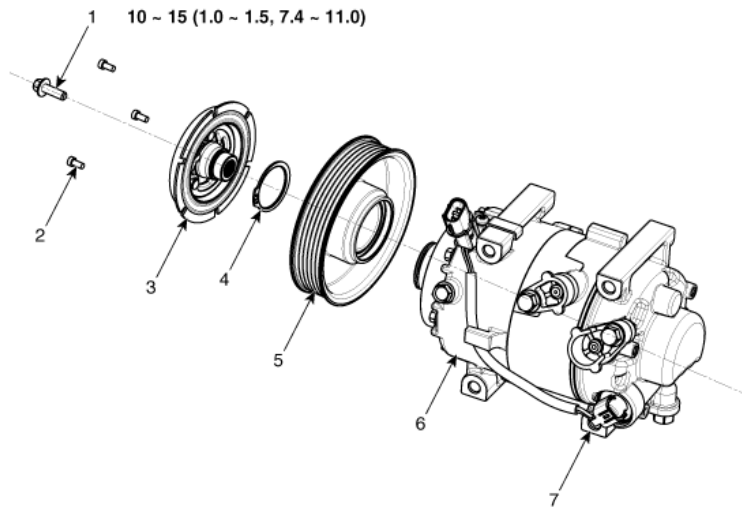

Tightening torque : N.m (kgf.m, lb-ft)

1. Clutch Bolt 2. Limiter Bolt 3. Limiter & Hub Assembly 4. Snap Ring 5. Pulley 6. Compressor Assembly 7. Electric Control Valve (ECV)
- Components Location

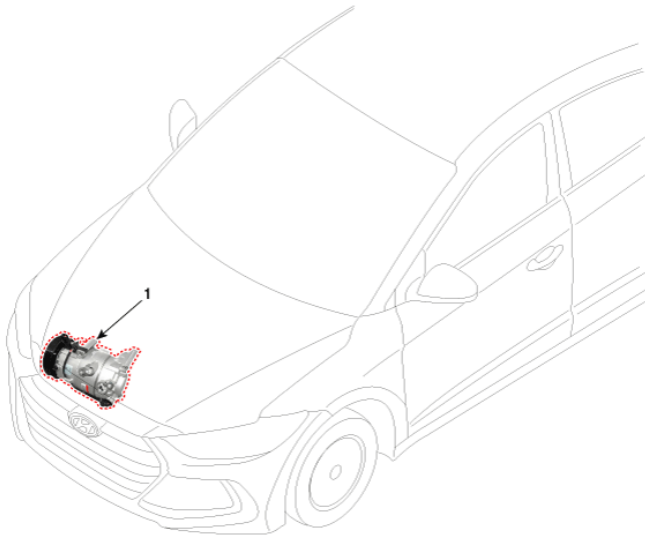

1. Compressor

Compressor - Repair Procedures (Article 44848)

- Removal

Precautions for using the plastic pulley Take care not to give physical impact to the plastic pulley. If exposed to the impact of dropping and collision, the pulley should not be used although not damaged. Be careful not to place the pulley to downwards of the floor or table. Be careful not to apply the external force and impact on pulley while moving or using. Be careful not to apply force to the pulley.

NOTICE

Precautions for using the plastic pulley

- Take care not to give physical impact to the plastic pulley. If exposed to the impact of dropping and collision, the pulley should not be used although not damaged.
- Be careful not to place the pulley to downwards of the floor or table.

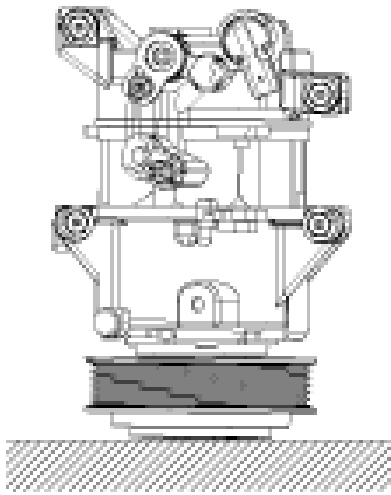

[X]

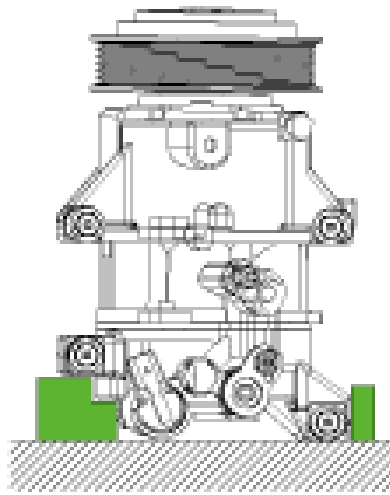

[O]

- Be careful not to apply the external force and impact on pulley while moving or using.

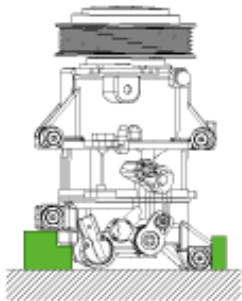

[O]

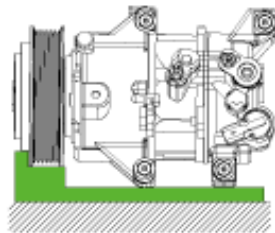

[O]

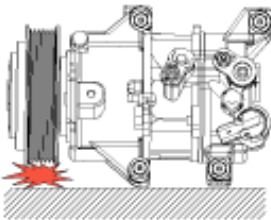

[X]

- Be careful not to apply force to the pulley.

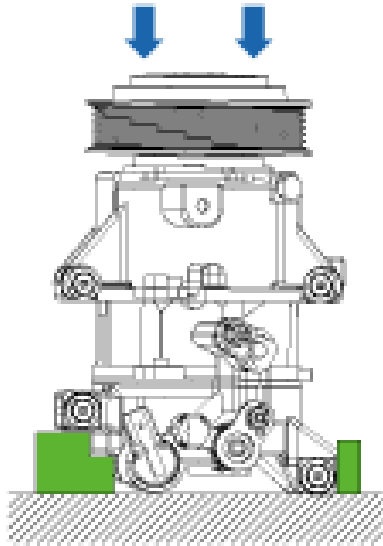

[X]

- If the compressor is marginally operable, run the engine at idle speed, and let the air conditioning work for a few minutes, then shut the engine off.
 - Disconnect the negative (-) battery terminal.
 - Recover the refrigerant with a recovery / charging station.
 - Remove the engine room under cover. (Refer to Engine Mechanical System - "Engine Room Cover")
 - Remove the front wheel guard. (Refer to Body - "Front Wheel Guard")
 - Loosen the drive belt. (Refer to Engine Mechanical System - "Drive Belt")
 - Remove the bolts, then disconnect the suction line (A) and discharge line (B) from the compressor.
- Tightening torque : 8.8 - 13.7 N.m (0.9 - 1.4 kgf.m, 6.5 - 10.1 lb-ft) Plug or cap the lines immediately after disconnecting them to avoid moisture and dust contamination.
- Plug or cap the lines immediately after disconnecting them to avoid moisture and dust contamination.
 - Plug or cap the lines immediately after disconnecting them to avoid moisture and dust contamination.

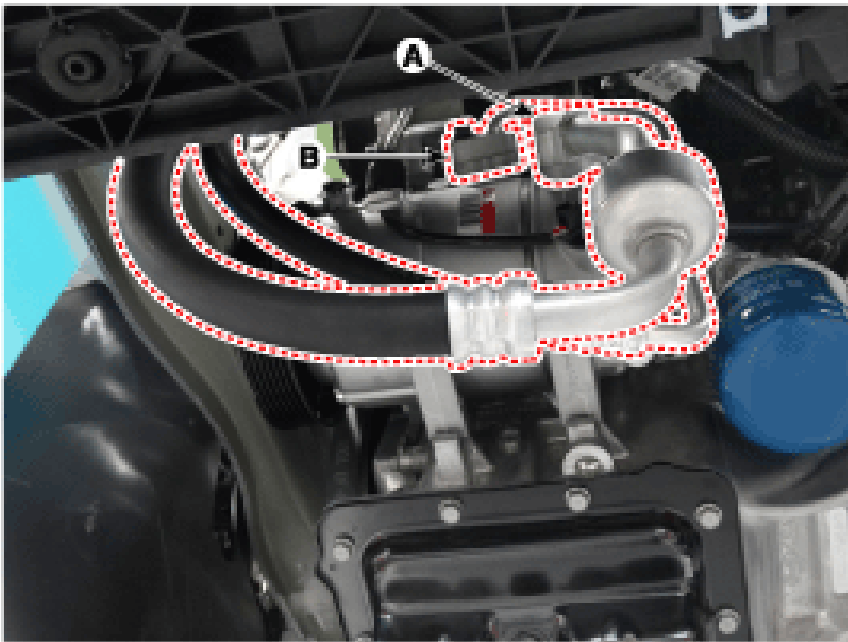

- Disconnect the compressor switch connector (A).

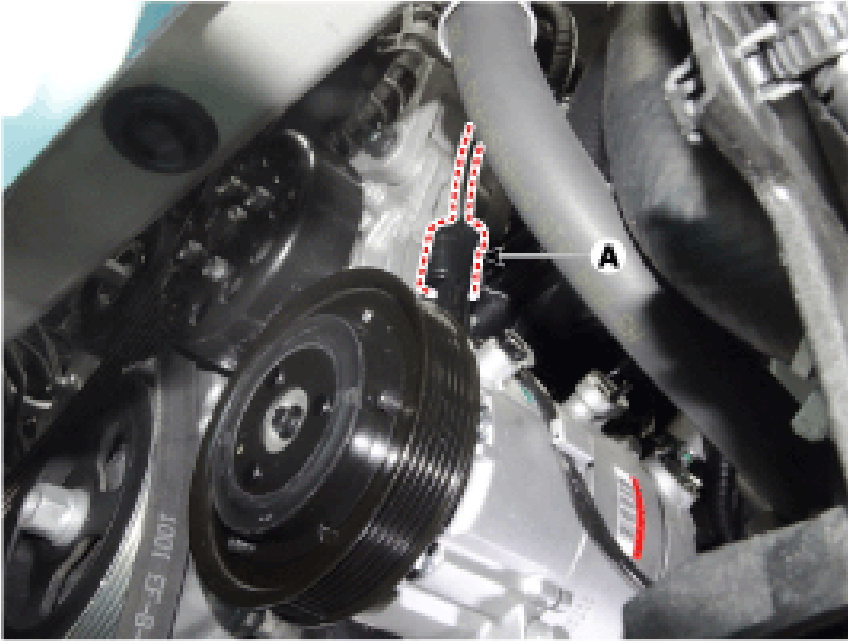

- Remove the compressor (A) by loosening the mounting bolts. Tightening torque : 20.0 - 32.95 N.m (2.04 - 3.36 kgf.m, 14.75 - 24.30 lb-ft)

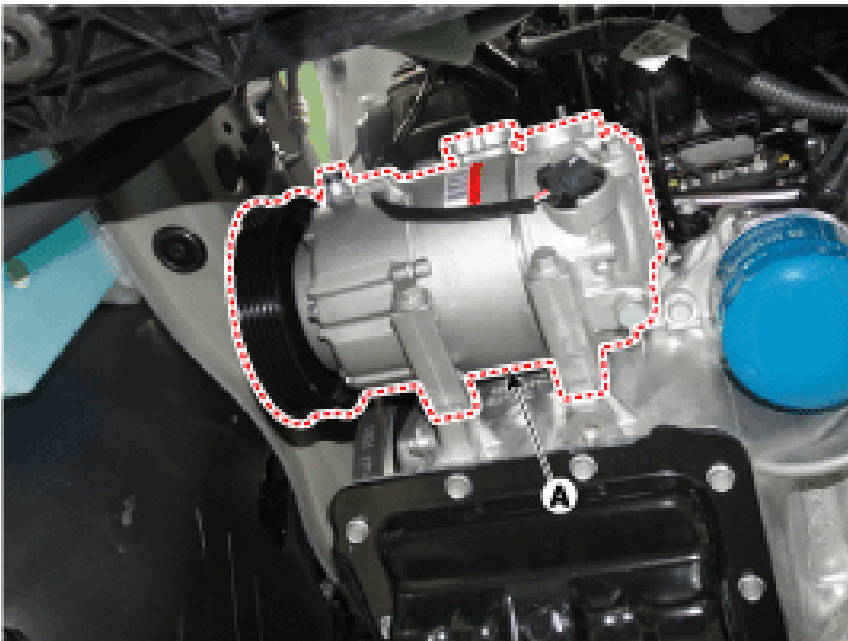

- Installation
- Make sure the compressor mounting bolt with the correct length is screwed in. Tighten the mounting bolts with the specified tightening order. Tightening torque : 20.0 - 32.95 N.m (2.04 - 3.36 kgf.m, 14.75 - 24.30 lb-ft)

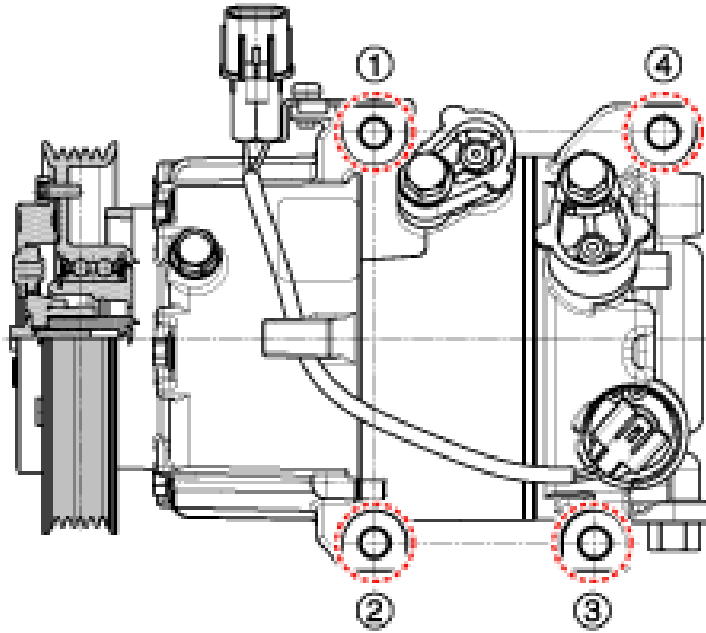

- To install, reverse the removal procedure. If you install a new compressor, drain all the refrigerant oil from the removed compressor and measure its volume. Subtract the volume of drained oil from the original capacity. The result is the amount of oilcompressor oil you should drain from the new compressor (through the suction fitting). Replace the O-rings with new ones at each fitting, and apply a thin coat of refrigerant oil before installing them. Be sure to use the right O-rings for R-134a or R-1234yf to avoid leakage. To avoid contamination, do not return the oil to the container once dispensed, and never mix it with other refrigerant oils. Immediately after using the oil, replace the cap on the container and seal it to avoid moisture absorption.

If you install a new compressor, drain all the refrigerant oil from the removed compressor and measure its volume. Subtract the volume of drained oil from the original capacity. The result is the amount of oilcompressor oil you should drain from the new compressor (through the suction fitting). Replace the O-rings with new ones at each fitting, and apply a thin coat of refrigerant oil before installing them. Be sure to use the right O-rings for R-134a or R-1234yf to avoid leakage. To avoid contamination, do not return the oil to the container once dispensed, and never mix it with other refrigerant oils. Immediately after using the oil, replace the cap on the container and seal it to avoid moisture absorption.

- If you install a new compressor, drain all the refrigerant oil from the removed compressor and measure its volume. Subtract the volume of drained oil from the original capacity. The result is the amount of oilcompressor oil you should drain from the new compressor (through the suction fitting).

- Replace the O-rings with new ones at each fitting, and apply a thin coat of refrigerant oil before installing them. Be sure to use the right O-rings for R-134a or R-1234yf to avoid leakage.

- To avoid contamination, do not return the oil to the container once dispensed, and never mix it with other refrigerant oils.

- Immediately after using the oil, replace the cap on the container and seal it to avoid moisture absorption.

- Inspection

- Check the plated parts of the limiter & hub assembly for color changes, peeling or other damage. If there is damage, replace the assembly.

- Check the pulley (A) bearing play and drag by rotating the pulley by hand. Replace the pulley with a new one if it is noisy or has excessive play / drag.

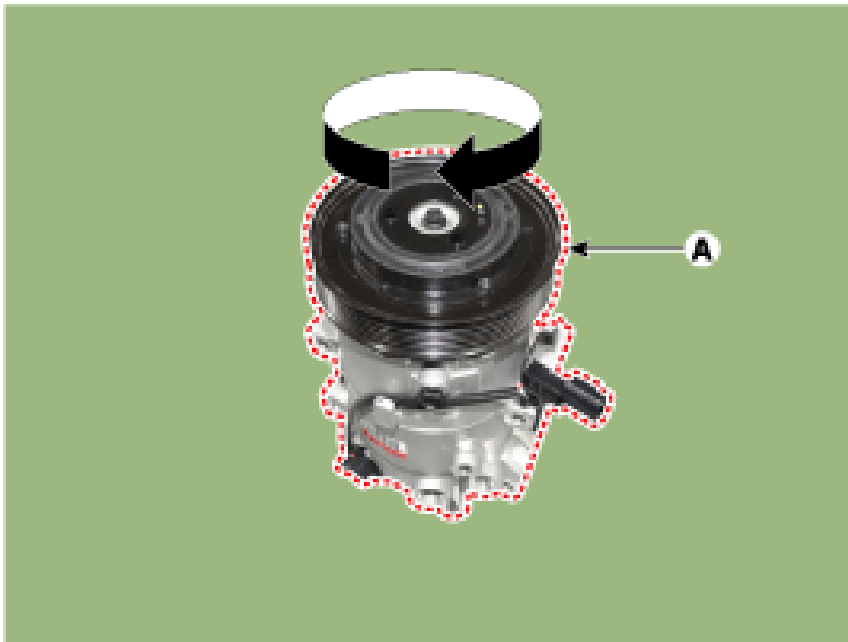

External Control Valve Compressor Inspection (GDS)

- Connect GDS to the vehicle and select 'Aircon Compressor Test (ECV type)' [ECV1]

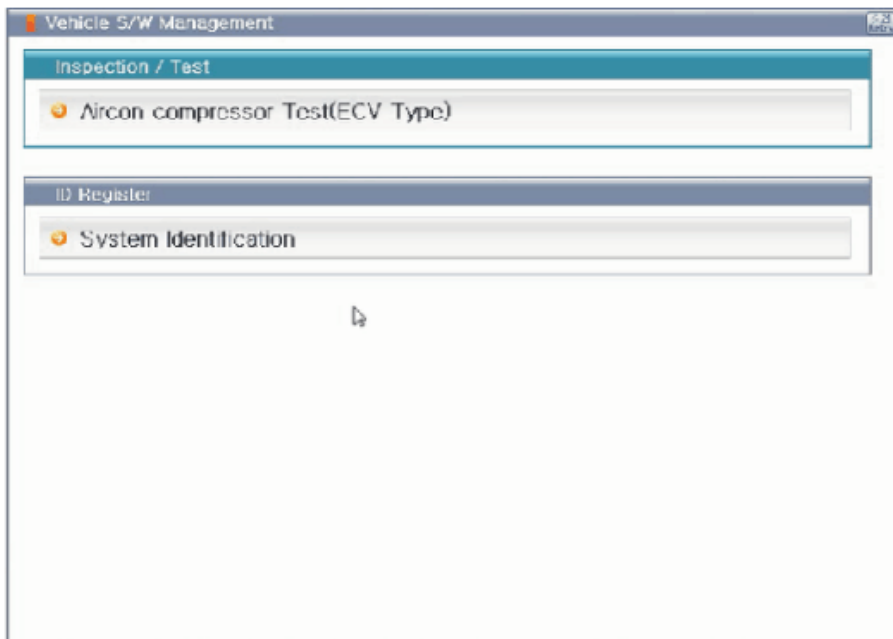

- Make the vehicle ready as the GDS instruction on the monitor. (Turn off A/C 'switch' only) [ECV2] [ECV3]

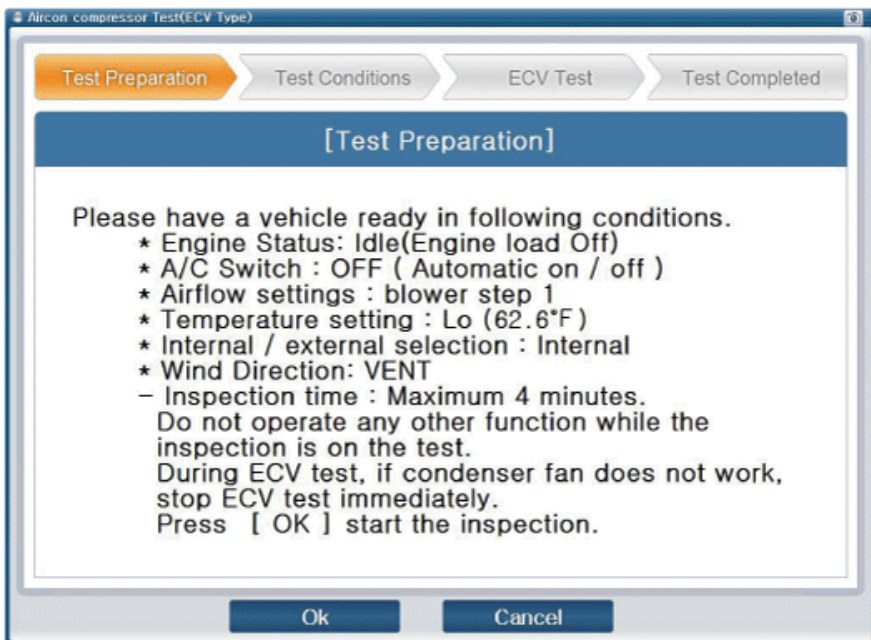
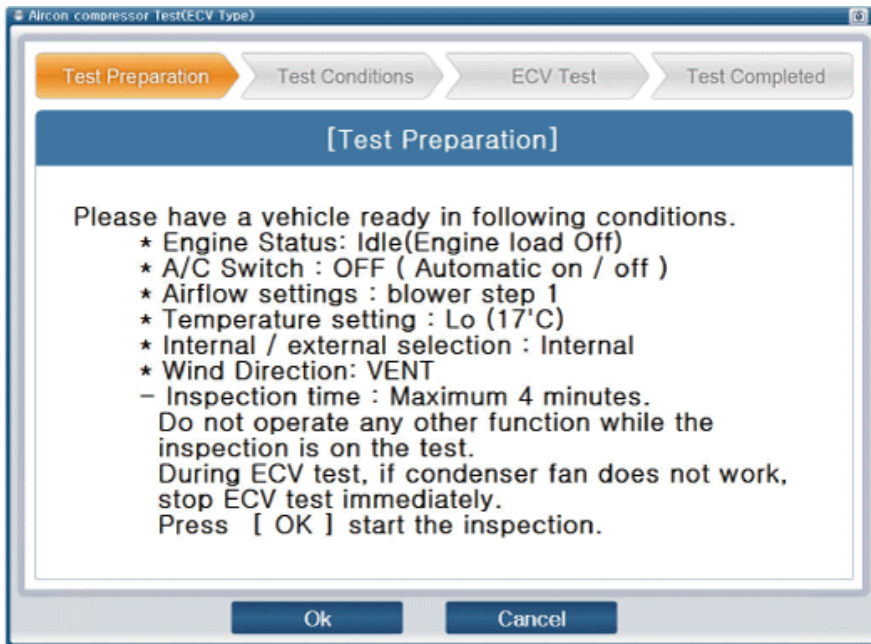

- Check if other DTC codes are found before inspect ECV compressor. If so, solve that problems first. If not, press 'OK' button to continue. Do not continue inspection if these DTC codes are found: B1241, B1242, B1672, B1685, B1686, B1687 [ECV4]

Do not continue inspection if these DTC codes are found: B1241, B1242, B1672, B1685, B1686, B1687



Information

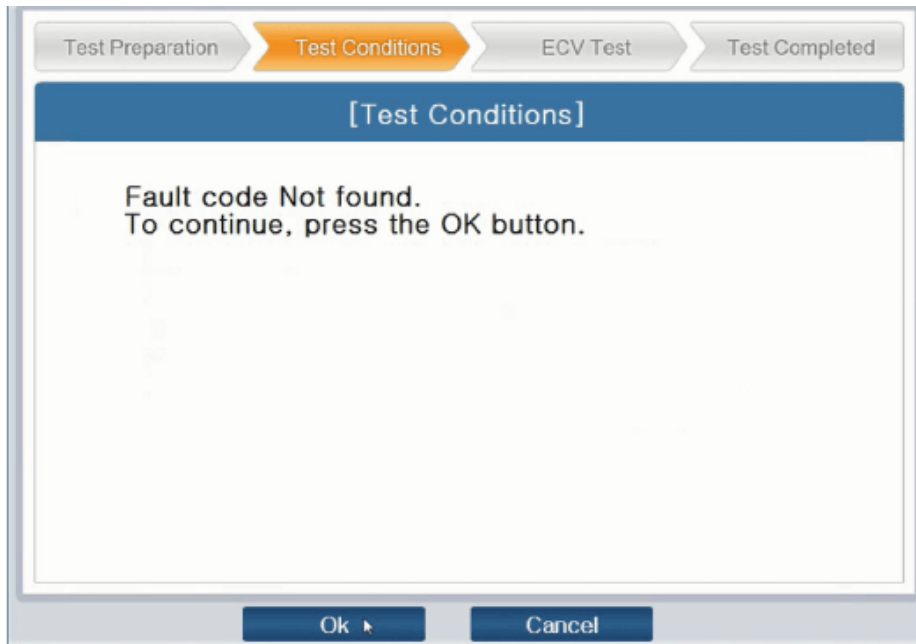

- Start inspection [ECV5] [ECV6] Check if condenser fan is operating when condition is changed to 'ECV running' Relief valve will be operated if a condenser fan doesn't work because of overpressure in the compressor. It allows the A/C system to relieve overpressure by releasing refrigerant and oil. (Closed if relieved) ■ Refill refrigerant and oil after operation of relief valve ■ Noise can be observed as the relief valve is in operation

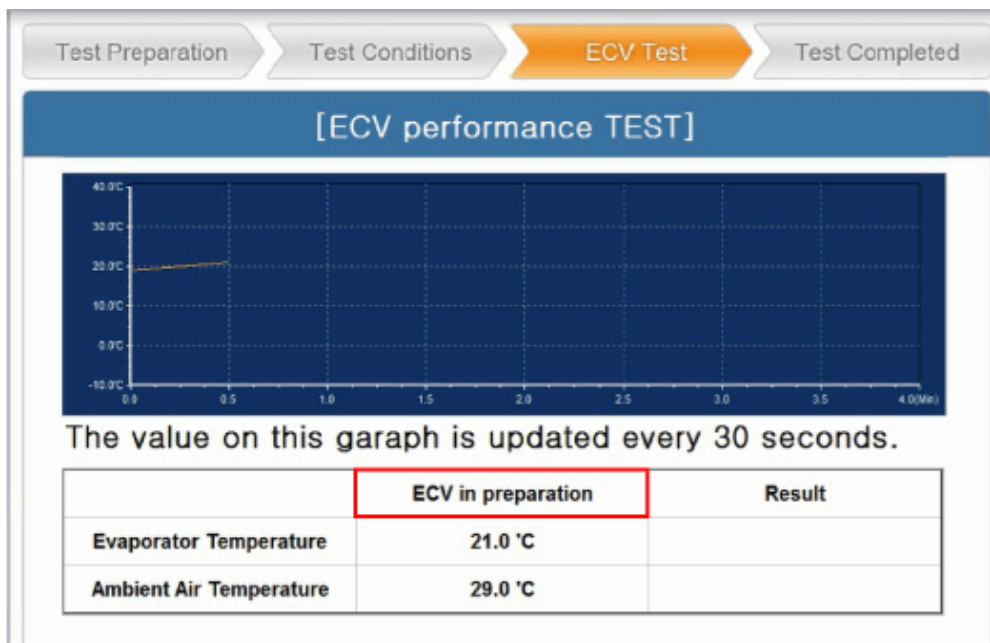

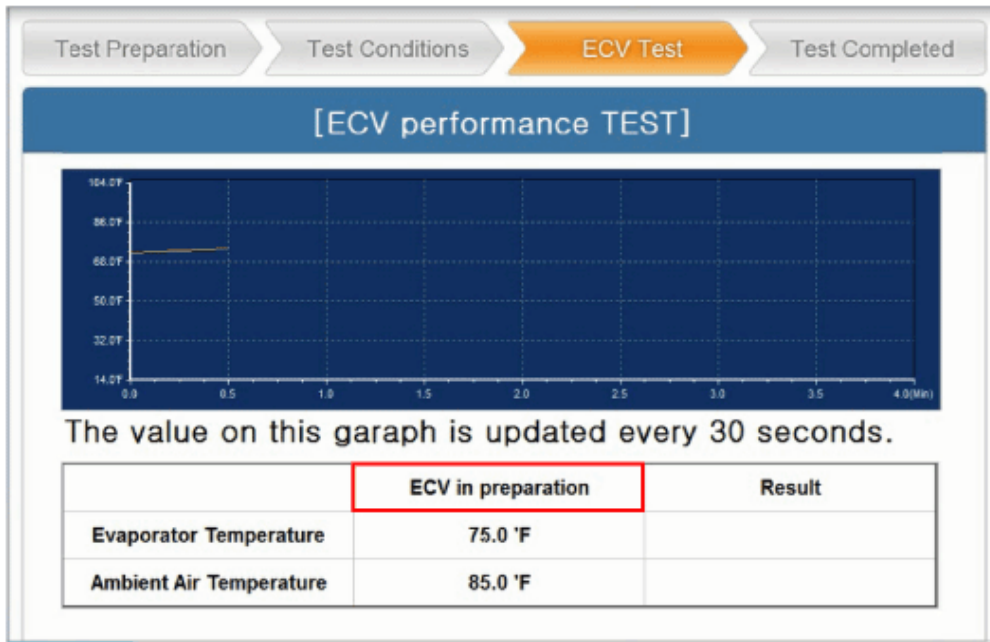

Check if condenser fan is operating when condition is changed to 'ECV running'



Relief valve will be operated if a condenser fan doesn't work because of overpressure in the compressor. It allows the A/C system to relieve overpressure by releasing refrigerant and oil. (Closed if relieved) ■ Refill refrigerant and oil after operation of relief valve ■ Noise can be observed as the relief valve is in operation

- Check the result of inspection and click 'Check Detail' if it's 'Check'. Follow the instruction and inspect ECV again from the first step. [ECV7] [ECV8]

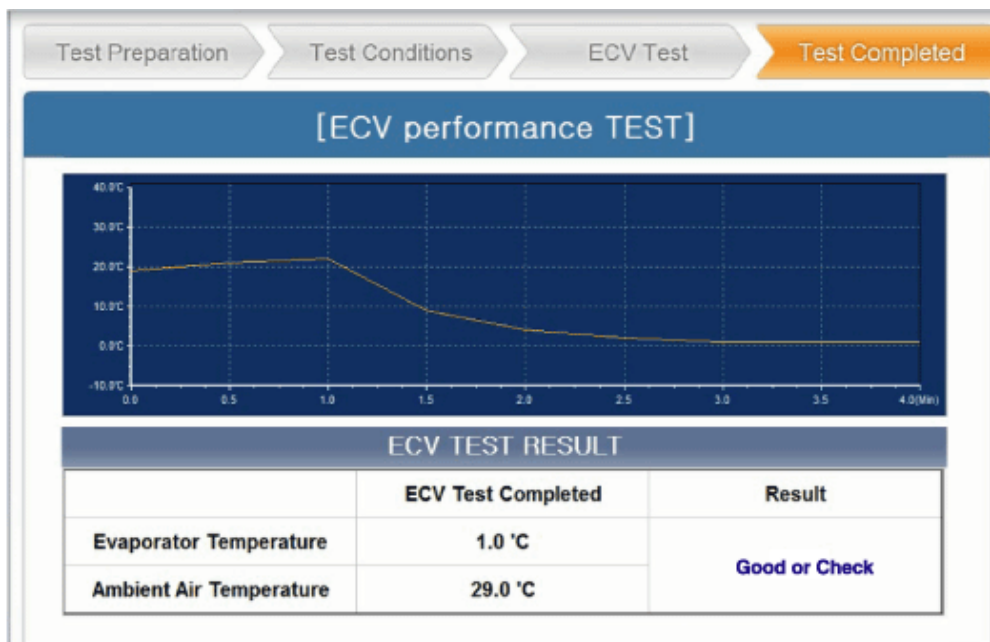

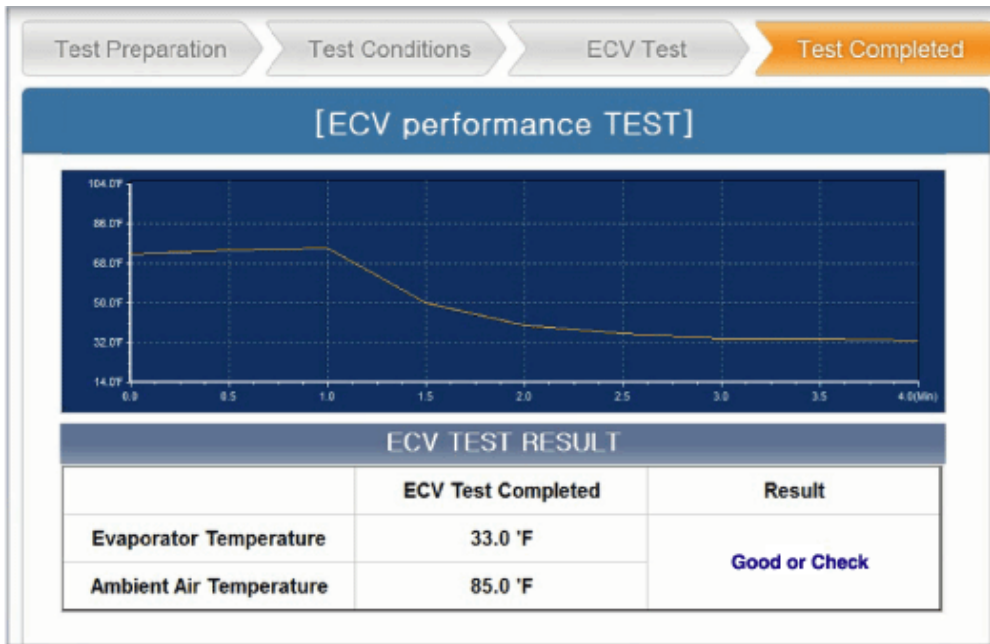

- Disassembly
- Remove the clutch bolt while holding the pulley with a clutch bolt remover (09977-3R000). Tightening torque : 10.0 - 15.0 N.m (1.02 - 1.53 kgf.m, 7.37 - 11.0 lb-ft)

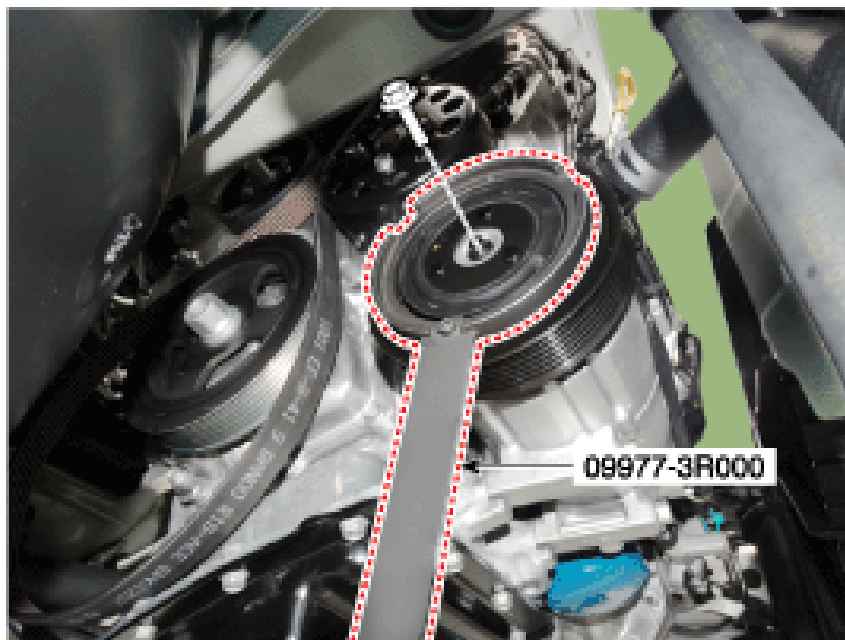

- Loosen the limiter bolts and then remove the limiter & hub assembly.

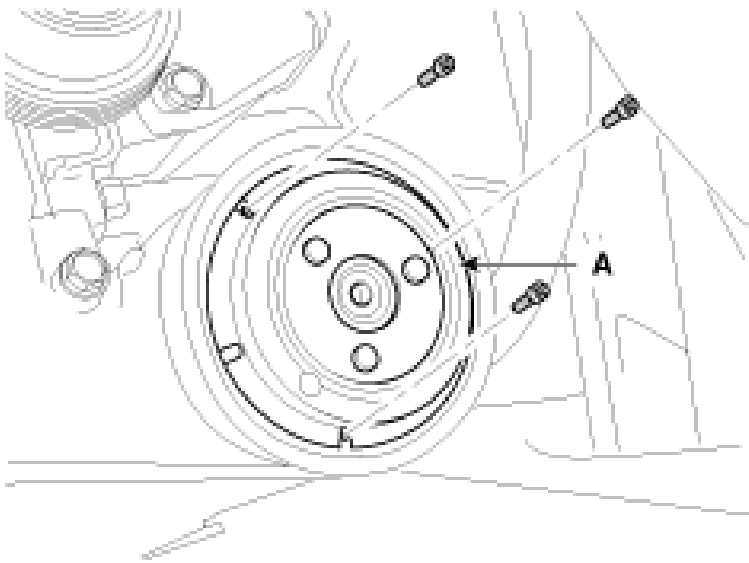

- Remove the pulley (B) after removing the snap ring (A) with a snap ring plier. Be careful not to damage the pulley and compressor during disassembly / reassembly. Once the snap ring is removed, replace it with a new one.

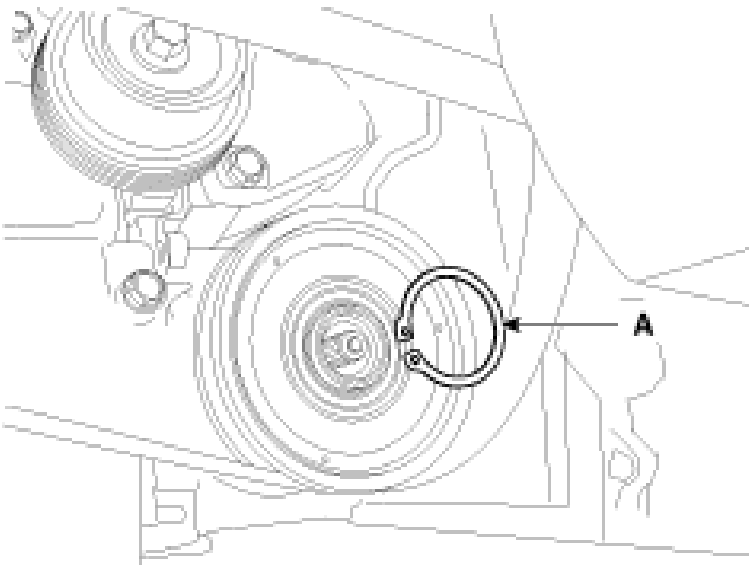

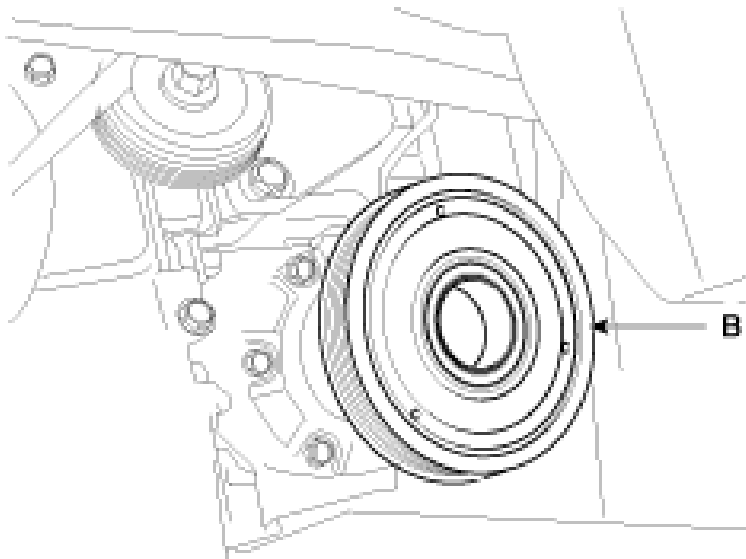

Be careful not to damage the pulley and compressor during disassembly / reassembly. Once the snap ring is removed, replace it with a new one.

- Be careful not to damage the pulley and compressor during disassembly / reassembly.
- Once the snap ring is removed, replace it with a new one.
- Reassemble in the reverse order of disassembly. Clean the pulley and compressor sliding surfaces with non-petroleum solvent. Install a new snap ring, and make sure they are fully seated in the groove. Make sure that the pulley turns smoothly after reassembly.
- Clean the pulley and compressor sliding surfaces with non-petroleum solvent.
- Install a new snap ring, and make sure they are fully seated in the groove.
- Make sure that the pulley turns smoothly after reassembly.

All Technical Service Bulletins (itype_100)

Tsbs

- A/C COMPRESSOR FIELD COIL SPECIFICATION AND DIAGNOSTIC GUIDELINE (20-HA-002H, 2020/07/01)