

# **Component Procedures: Vacuum Brake Booster**

## **Table of Contents**

1. Parts and Labor (itype\_189)
2. Brake Booster - Components and Components Location (Article 45165)
3. Brake Booster - Repair Procedures (Article 45166)

# Component Procedures: Vacuum Brake Booster

## Parts and Labor (itype\_189)

### Parts

| Qualifier                     | Part #     | Name        | Price  | Note |
|-------------------------------|------------|-------------|--------|------|
| Hydraulic System > Brake Boo? | 59110F2000 | Korea Built | 808.84 |      |
| Hydraulic System > Brake Boo? | 59110F3000 | Us Built    | 500.79 |      |

### Labor

| Operation        | Qualifier Path                        | Skill | Std Hrs | Wty Hrs |
|------------------|---------------------------------------|-------|---------|---------|
| Remove & Replace | Hydraulic System > Booster Hose, R&R  | B     | 0.3     | 0.0     |
| Remove & Replace | Hydraulic System > Brake Booster, R&R | B     | 1.8     | 0.0     |

## Brake Booster - Components and Components Location (Article 45165)

- Components

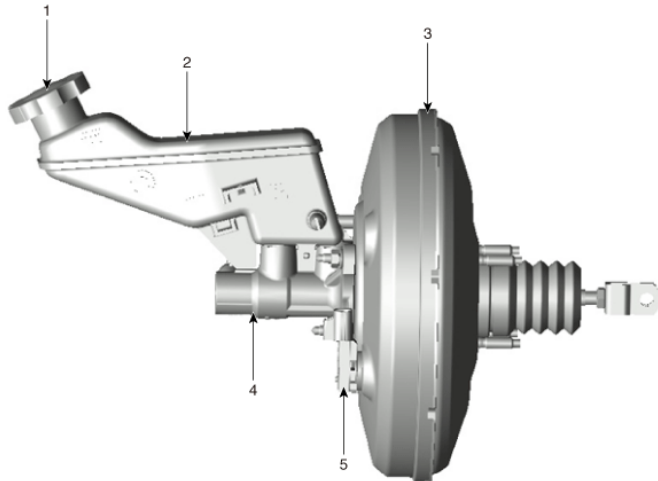

1. Reservoir cap 2. Reservoir 3. Booster 4. Master cylinder 5. Booster pressure sensor

## Brake Booster - Repair Procedures (Article 45166)

- Brake Booster Operating Test

- Run the engine for one or two minutes, and then stop it. If the pedal depresses fully the first time but gradually becomes higher when depressed succeeding times, the booster is operating properly, if the pedal height remains unchanged, the booster is inoperative.

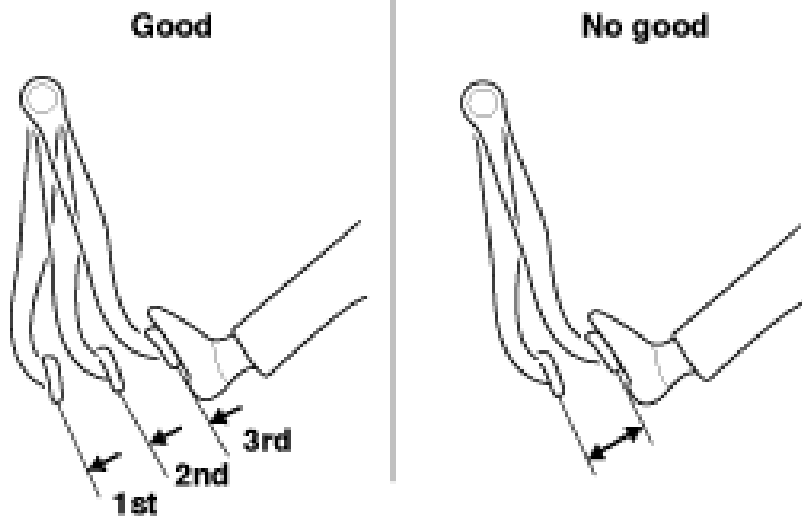

- With the engine stopped, step on the brake pedal several times. Then step on the brake pedal and start the engine. If the pedal moves downward slightly, the booster is in good condition. If there is no change, the booster is inoperative.

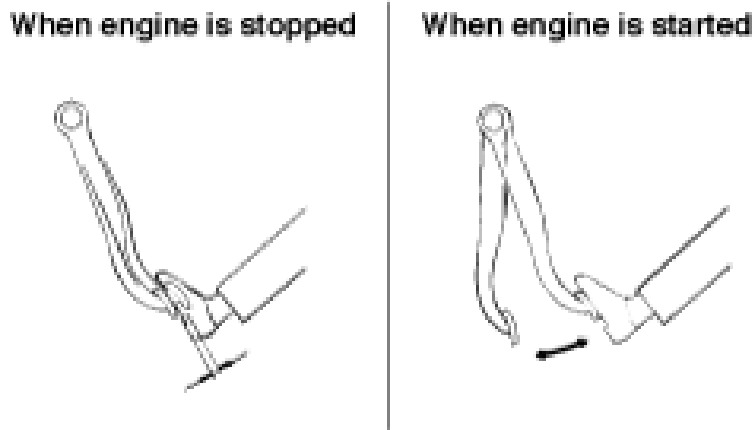

- With the engine running, step on the brake pedal and then stop the engine. Hold the pedal depressed for 30 seconds. If the pedal height does not change, the booster is in good condition, if the pedal rises, the booster is inoperative. If the above three tests are okay, the booster performance can be determined as good. Even if one of the above three tests is not okay, check the check valve, vacuum hose and booster for malfunction.

Good



No good



- Removal
- Turn ignition switch OFF and disconnect the negative (-) battery cable.
- Remove the battery. (Refer to Engine Electrical System - "Battery")
- Remove the ECM (A).

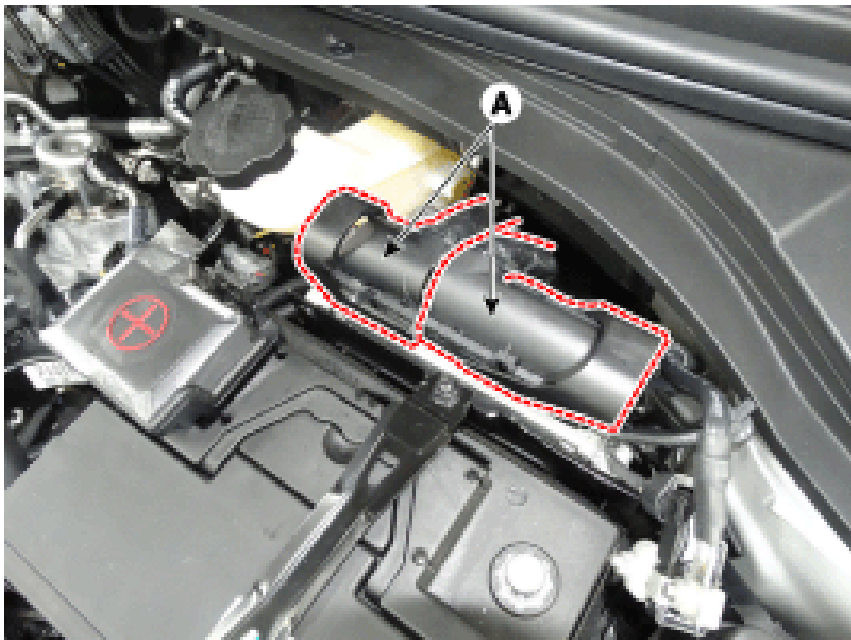

- Loosen the mounting bolts (A) and then remove the ECM bracket (B).

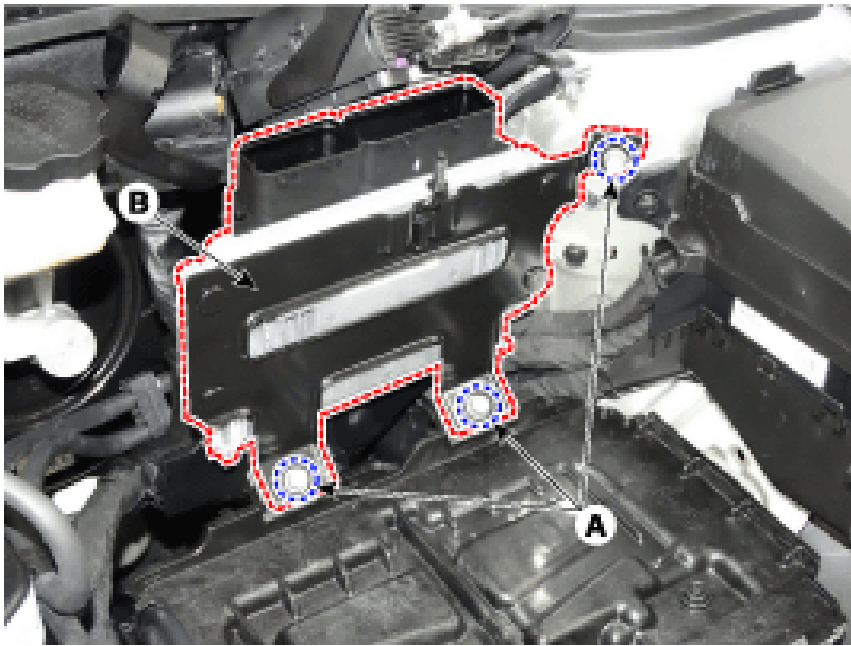

- Disconnect the brake fluid level switch connector.



- Remove the vacuum hose (A).

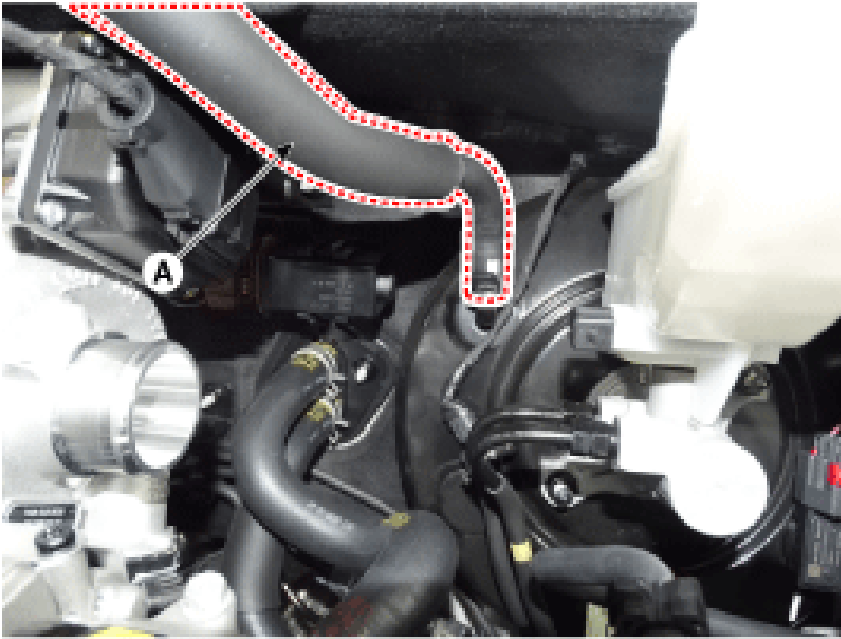

- Remove the brake fluid from the master cylinder reservoir with a syringe. Do not spill brake fluid on the vehicle, it may damage the paint; if brake fluid does contact the paint, wash it off immediately with water. Do not spill brake fluid on the vehicle, it may damage the paint; if brake fluid does contact the paint, wash it off immediately with water.

# NOTICE

- Do not spill brake fluid on the vehicle, it may damage the paint; if brake fluid does contact the paint, wash it off immediately with water.
- Remove the master cylinder . (Refer to Brake System - "Master Cylinder")
- Remove the snap pin (A) and clevis pin (B).



- Remove the mounting nuts (A). Tightening torque : 16.7 - 25.5 N.m (1.7 - 2.6 kgf.m, 12.3 - 18.8 lb-ft)

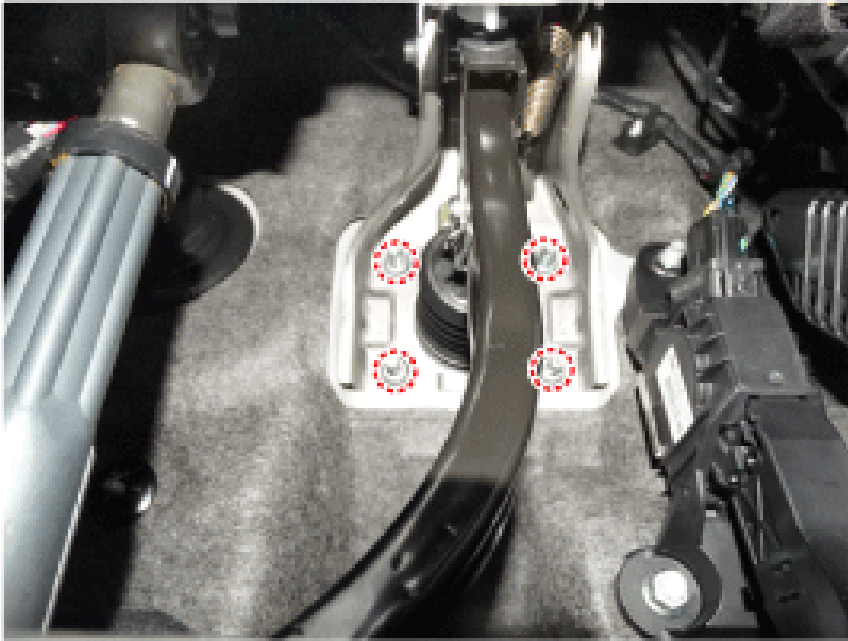

- Remove the brake booster.

- Inspection

- Inspect the vacuum hose.

- Check the boot for damage.

- Installation

- To install, reverse the removal procedure. Before installing the pin, apply the grease to the joint pin. Use a new snap pin whenever installing.

Before installing the pin, apply the grease to the joint pin. Use a new snap pin whenever installing.

- Before installing the pin, apply the grease to the joint pin.

- Use a new snap pin whenever installing.

- After installing, bleed the brake system. (Refer to Brake System - "Brake System Bleeding") (Refer to Brake System - "ABS System Bleeding") (Refer to Brake System - "ESP System Bleeding")