

Component Procedures: Clutch Switch

Table of Contents

1. Clutch Switch - Description and Operation (Article 45240)
2. Ignition Lock Switch - Description and Operation (Article 45237)
3. Clutch Switch - Repair Procedures (Article 45241)
4. Ignition Lock Switch - Repair Procedures (Article 45238)
5. Clutch Switch - Specifications (Article 45239)
6. Ignition Lock Switch - Specifications (Article 45236)

Component Procedures: Clutch Switch

Clutch Switch - Description and Operation (Article 45240)

- Description
- Clutch operation is detected through clutch switch signal. This signal enables ECM to cope with instant change of load condition.
- Clutch switch signal is used to detect engaged gear with vehicle speed and engine speed.

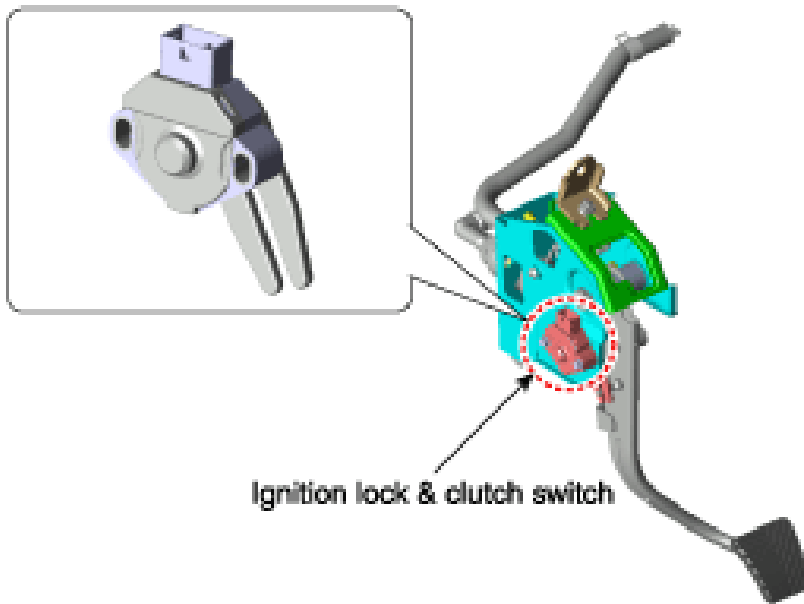

Ignition lock & clutch switch operating locus

- If the clutch pedal is pressed down, (A) operate clutch switch at a location.

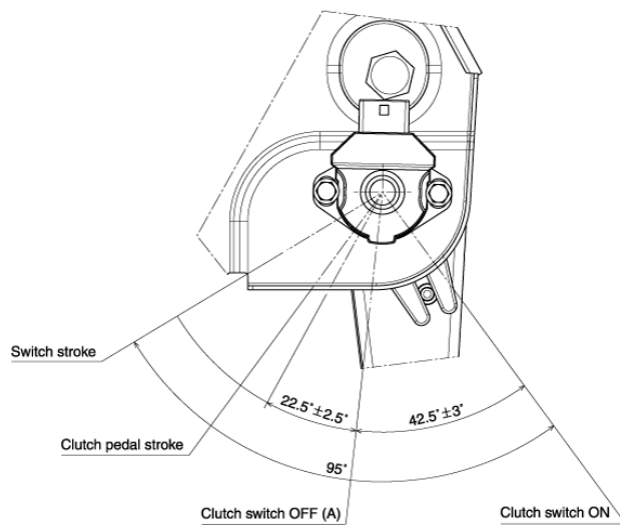

Ignition Lock Switch - Description and Operation (Article 45237)

- Description
- Ignition lock switch is mounted on the clutch pedal .
- Ignition lock switch is operated when you press the clutch pedal.
- If the clutch pedal is not pressed down, the engine is not started.

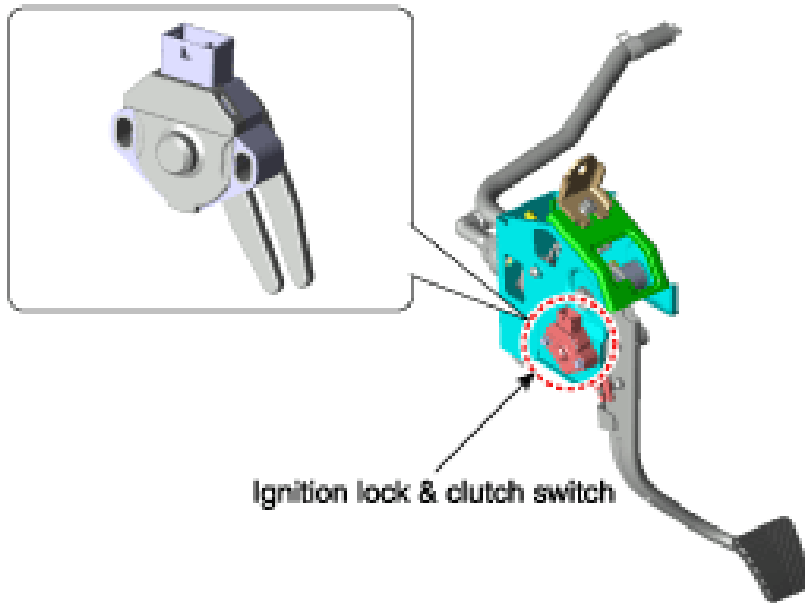

Ignition lock & clutch switch operating locus

- If the clutch pedal is pressed down, (A) operate ignition lock switch at a location.

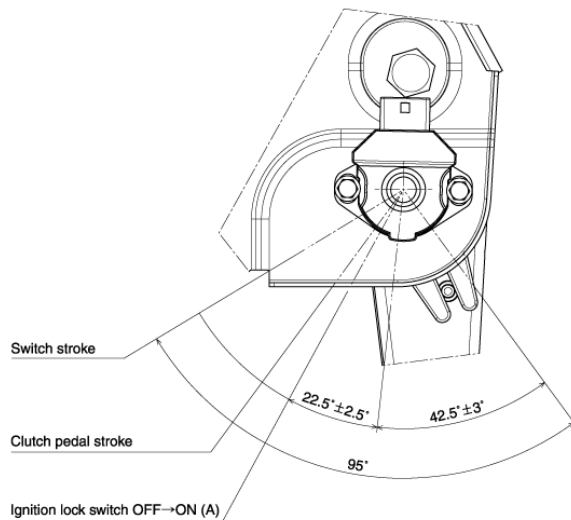

Clutch Switch - Repair Procedures (Article 45241)

- Removal
- Turn ignition switch OFF and disconnect the negative (-) battery cable .
- Disconnect the ignition lock & clutch switch connector (A).



- Remove the ignition lock & clutch switch (A) after removing the bolt (B-2ea).

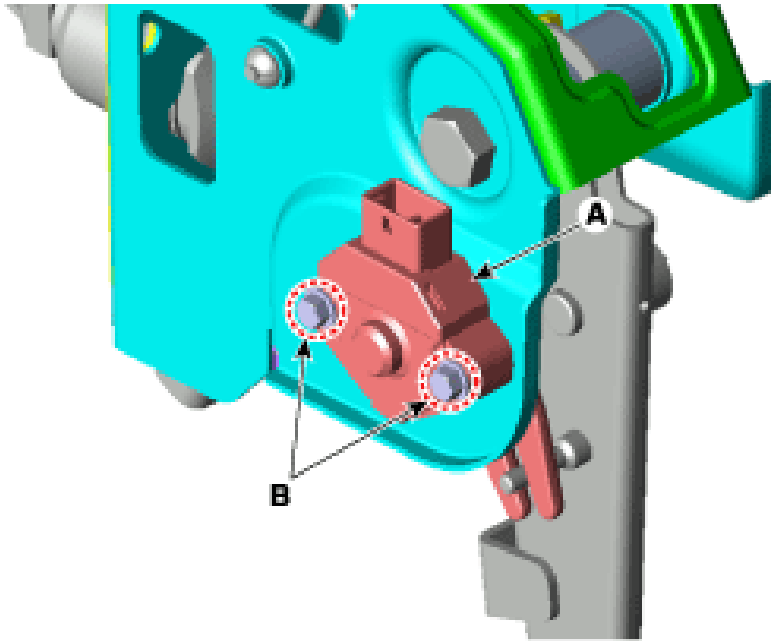

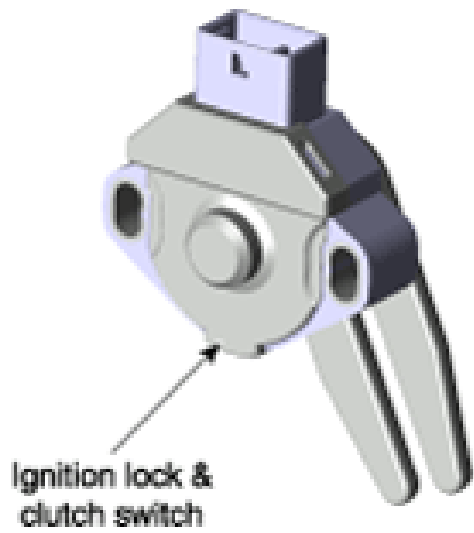

- Inspection

Component Inspection

- Turn ignition switch OFF and disconnect the negative (-) battery cable.
- Remove the ignition lock & clutch switch.
- Rotate the switch lever to the direction of the arrow to check the operating point (A).

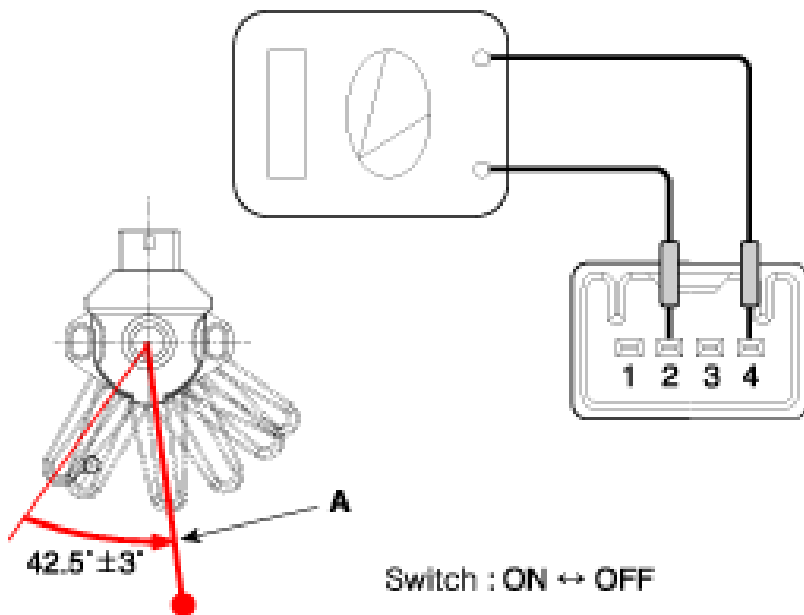

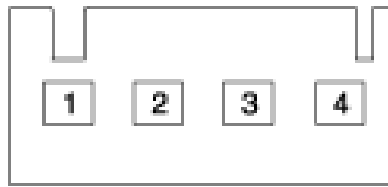

- 1. Ignition lock switch (-)
- 2. Clutch switch (-)
- 3. Ignition lock switch (-)
- 4. Clutch switch (+)

*** Circuit Diagram**

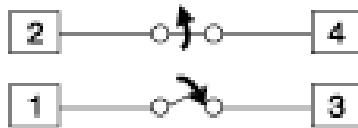

- Installation

- Install is proceeds as follows. ■ How to install the ignition lock & clutch switch (A) After inserting the switch lever (A) into the clutch pedal pin (B), pre-tighten the switch mounting bolt (C). (B) Set the clutch switches so as to confirm that the electric current is applied to the pins ② and ④. (C)Fix the clutch pedal to the ignition lock switch ON→OFF strokes (F). (D) With the pedal fixed, rotate the switch clockwise and counter-clockwise to set it to a position at the transition from ON to OFF. Then, tighten the mounting bolt (C) to the specified torque. (E) Once completing the assembly, check again that the switch is correctly operating. ■ ON→OFF stroke tolerance should be within ± 3 mm (0.1181 in.) ON → OFF Position (F) 70 ± 3 mm (2.7559 \pm 0.1181 in.) Tightening torque : 2.0 - 5.9 N.m (0.2 - 0.6 kgf.m, 1.4 - 4.3 lb-ft)

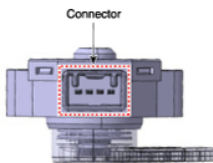
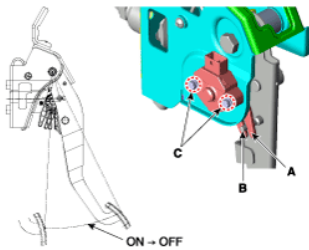

Type	Item Check
Clutch switch	

Ignition Lock Switch - Repair Procedures (Article 45238)

- Removal
- Turn ignition switch OFF and disconnect the negative (-) battery cable .
- Disconnect the ignition lock & clutch switch connector (A).



- Remove the ignition lock & clutch switch (A) after removing the bolt (B-2ea).

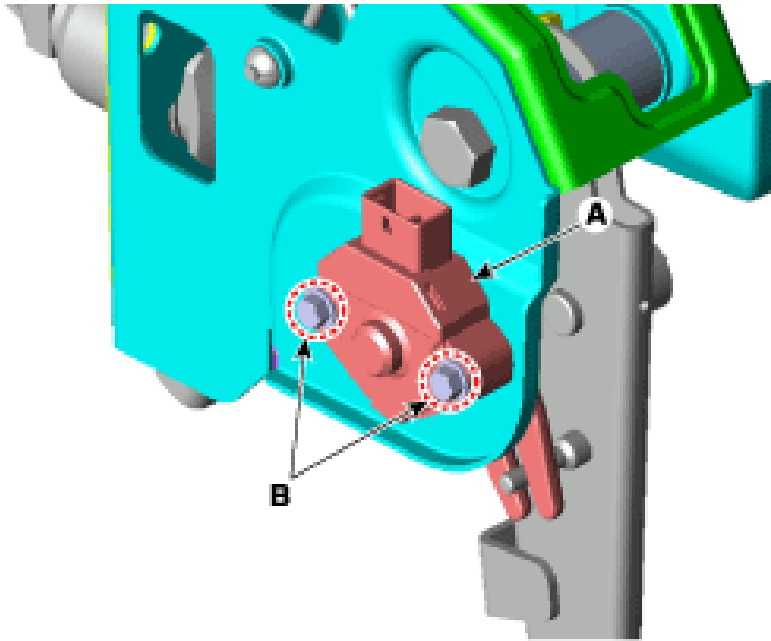

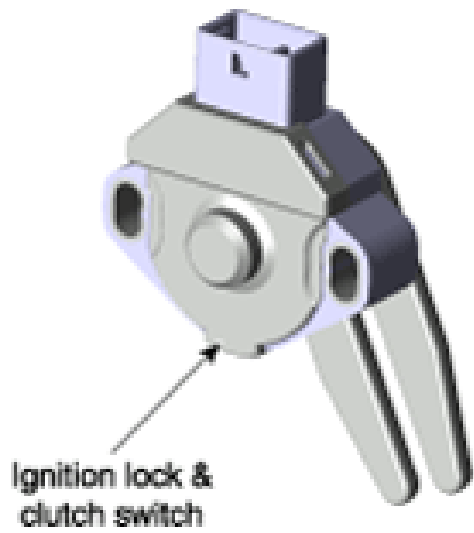

- Inspection

Component Inspection

- Turn ignition switch OFF and disconnect the negative (-) battery cable.
- Remove the ignition lock & clutch switch.
- Rotate the switch lever to the direction of the arrow to check the operating point (A).

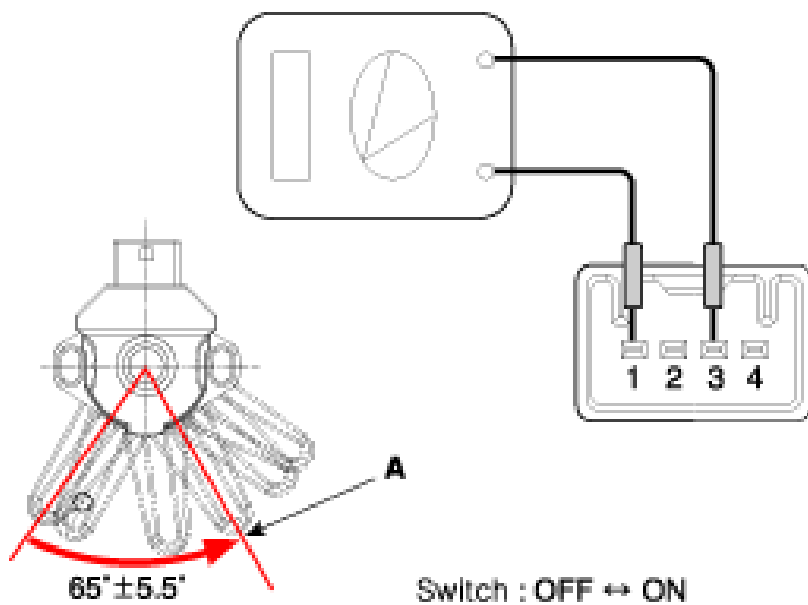

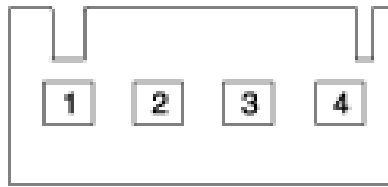

- 1. Ignition lock switch (-)
- 2. Clutch switch (-)
- 3. Ignition lock switch (-)
- 4. Clutch switch (+)

*** Circuit Diagram**

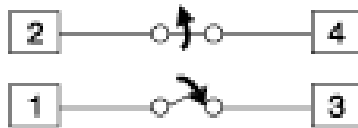

- Installation

- Install is proceeds as follows. ■ How to install the ignition lock & clutch switch (A) After inserting the switch lever (A) into the clutch pedal pin (B), pre-tighten the switch mounting bolt (C). (B) Set the clutch switches so as to confirm that the electric current is applied to the pins ① and ③. (C) Fix the clutch pedal to the ignition lock switch OFF→ON strokes (F). (D) With the pedal fixed, rotate the switch clockwise and counter-clockwise to set it to a position at the transition from OFF to ON. Then, tighten the mounting bolt (C) to the specified torque. (E) Once completing the assembly, check again that the switch is correctly operating. ■ OFF→ON stroke tolerance should be within ± 7.7 mm (0.3031 in.) OFF → ON Position (F) 121.8 ± 7.7 mm (4.7953 ± 0.3031 in.) Tightening torque : 2.0 - 5.9 N.m (0.2 - 0.6 kgf.m, 1.4 - 4.3 lb-ft)

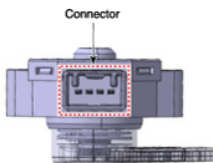
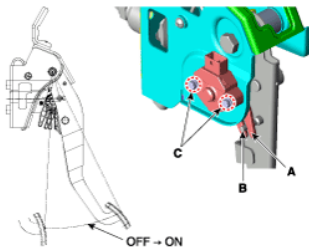

Type	Item Check
Ignition lock switch	

Clutch Switch - Specifications (Article 45239)

- Specifications

Item Specifications

Working voltage DC 12V

Operating force Initial position : 0.25 ± 0.15 N(0.025 ± 0.015 kg, 0.056 ± 0.034 lb)

Full position : 0.8 ± 0.2 N(0.08 ± 0.02 kgf, 0.579 ± 0.014 lb-ft)

Working temperature -40°C to 80°C (-40°F to 176°F)

Ignition Lock Switch - Specifications (Article 45236)

- Specifications

Item Specifications

Working voltage DC 12V

Operating force Initial position : $0.25 \pm 0.15\text{N}$ ($0.025 \pm 0.015\text{kg}$, $0.056 \pm 0.034\text{lb}$)

Full position : $0.8 \pm 0.2\text{ N}$ ($0.08 \pm 0.02\text{ kgf}$, $0.579 \pm 0.014\text{ lb-ft}$)

Working temperature -40°C to 80°C (-40°F to 176°F)