

# **Component Procedures: Memory Positioning Systems**

## **Table of Contents**

1. IMS (Integrated Memory System) - Description and Operation (Article 44545)
2. IMS (Integrated Memory System) - Schematic Diagrams (Article 44543)
3. Integrated Memory System (IMS) - Schematic Diagrams (Article 42514)
4. Memory Systems - Driver's Memory Seat Circuit (Article 10486)
5. Memory Systems - Memory Mirrors Circuit (Article 10483)
6. IMS (Integrated Memory System) - Components and Components Location (Article 44542)
7. IMS (Integrated Memory System) - Specifications (Article 44541)

# Component Procedures: Memory Positioning Systems

## IMS (Integrated Memory System) - Description and Operation (Article 44545)

- Description
- Manual operation: Motor control with the seat manual switch The position of the seat is changed by operating the motor when the signal is input with manual switch for the seat (Slide, recline, front tilt, rear height adjusting)
- The position of the seat is changed by operating the motor when the signal is input with manual switch for the seat (Slide, recline, front tilt, rear height adjusting)
- Memory function : Available for memorizing/reproducing the data for two persons with IMS switch. The memorized motion (seat and outside mirror s) for the optimal seal position set by the driver based on the CAN data (IMS→ DDM ) with IMS switch. Reproduction by the CAN data received from IMS switch controlling.
- The memorized motion (seat and outside mirror s) for the optimal seal position set by the driver based on the CAN data (IMS→ DDM ) with IMS switch.
- Reproduction by the CAN data received from IMS switch controlling.
- Motion linked for getting on/off Function of getting on/off linked motion depending on the state of ON/OFF the engine Use of IMS CAN data communication Condition for operating getting on : When the electric power is in ACC Condition for operating getting off : When the engine is OFF
- Function of getting on/off linked motion depending on the state of ON/OFF the engine
- Use of IMS CAN data communication
- Condition for operating getting on : When the electric power is in ACC
- Condition for operating getting off : When the engine is OFF
- Memorization and Recall of Mirror Position Using Memory Switch System Description IMS switch inputs are received by Power Seat Module (PSM). Receiving the IMS switch inputs, the PSM will send the information to DDM and ADM via CAN communication. Receiving the information from the PSM, the DDM and the ADM will memorize and recall it. They carry out the memorization and recall operation if the following conditions are met : IGN ON Gear selected in P (Park) position The vehicle speed is "0 km/h" according to the information transmitted from the BCM via CAN communication. Save Mirror Position Move the mirrors on the sides of driver and passenger seats to desired positions. Press the SET switch from IMS switches. Press the switch 1 or 2 within the limited time period. The mirror positions will be stored in the IMS switch 1 or 2 of the DDM and the ADM.
- System Description IMS switch inputs are received by Power Seat Module (PSM). Receiving the IMS switch inputs, the PSM will send the information to DDM and ADM via CAN communication. Receiving the information from the PSM, the DDM and the ADM will memorize and recall it.
- IMS switch inputs are received by Power Seat Module (PSM).
- Receiving the IMS switch inputs, the PSM will send the information to DDM and ADM via CAN communication.
- Receiving the information from the PSM, the DDM and the ADM will memorize and recall it.
- They carry out the memorization and recall operation if the following conditions are met : IGN ON Gear selected in P (Park) position The vehicle speed is "0 km/h" according to the information transmitted from the BCM via CAN communication.
- IGN ON
- Gear selected in P (Park) position
- The vehicle speed is "0 km/h" according to the information transmitted from the BCM via CAN communication.
- Save Mirror Position Move the mirrors on the sides of driver and passenger seats to desired positions. Press the SET switch from IMS switches. Press the switch 1 or 2 within the limited time period. The mirror positions will be stored in the IMS switch 1 or 2 of the DDM and the ADM.
- Move the mirrors on the sides of driver and passenger seats to desired positions.
- Press the SET switch from IMS switches.
- Press the switch 1 or 2 within the limited time period.
- The mirror positions will be stored in the IMS switch 1 or 2 of the DDM and the ADM.
- Operation
- Reproducing Motion
- The buzzer is operated once and adjusted automatically to the memorized position when the CAN data is received from IMS.
- The CAN data which is not memorized do not operate for reproduction.
- The finally received CAN data for reproduction shall be preferred when other CAN data is received during reproduction motion.
- The seat stops the reproduction when reproducing CAN data is received by pressing button 1 or 2 during reproduction.
- The seat stops the reproducing when the memorized CAN data is received by pressing SET button during reproduction. Press the SET button once more to store the position of stop.

Press the SET button once more to store the position of stop.

# NOTICE

- Press the SET button once more to store the position of stop.
- Automatic stop when seat is virtual limit position during reproduction.
- Do not operate the motor when the difference between the memorized position for reproduction and current position is less than 4 pulses.

## Conditions for Prohibiting the Reproduction

- IGN2 OFF (Excluding within 30 seconds after door opening or closing.)
- Higher than 3km/h of vehicle speed
- When the switch is controlled manually
- Operation time chart

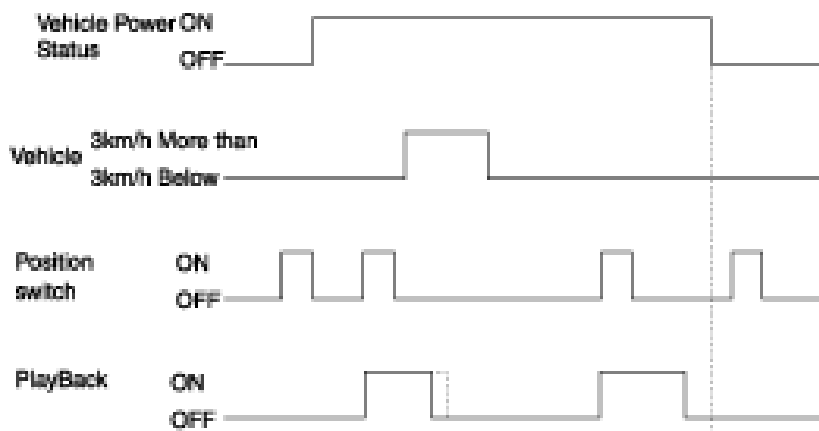

## Decision On the Operation Priority

- The motor operation shall be delayed for  $100 \pm 10$  msec for preventing the overlapping of inrush circuit during motor start and the priority at this case shall be as follows. Slide ■ Backrest adjustment ■ Front height adjustment ■ Rear height adjustment Operation time chart

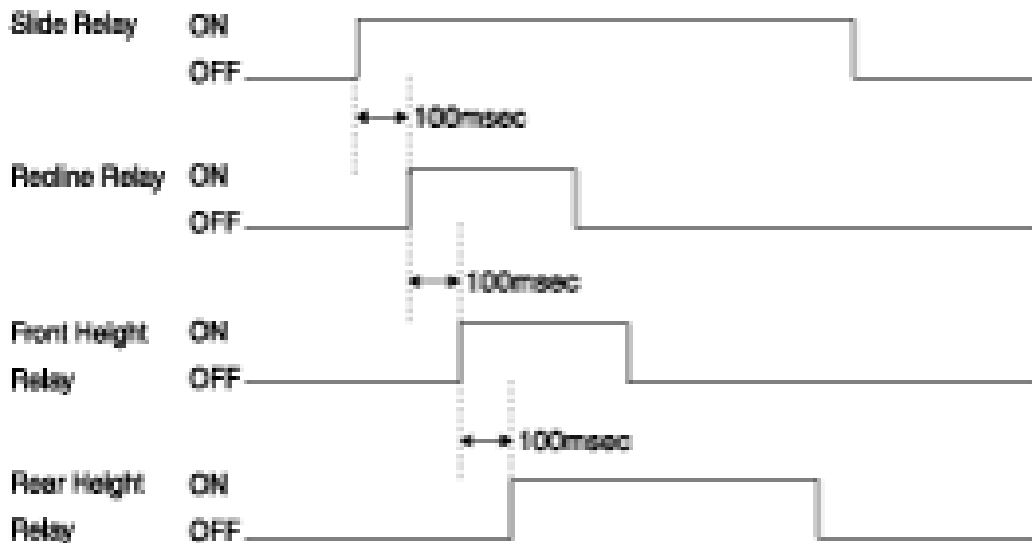

#### Operation Linked with Getting On/getting Off

- Returning motion to backwards during getting off and to forwards during getting on (Corresponding to slide only)
- Starting of operation when the engine is off.
- Moving to the targeted position of ACC ON
- Behavior prohibited conditions Vehicle speed 3km/h Power seats, if the operation of the manual control switch. Driver Settings menu (USM) is Off, Passenger action on receipt of the play command
- Vehicle speed 3km/h
- Power seats, if the operation of the manual control switch.
- Driver Settings menu (USM) is Off,
- Passenger action on receipt of the play command

#### Virtual Limit

- Virtual Limit Setting Conditions and Positions Set an arbitrary virtual limit using any methods below since there is no independent limit switch, restricting driving of slide, backrest, and front / rear height adjusting motors : Slide recall: When there is no slide motor pulse inputted (mechanical end stop) through 6 or more pulses for 2 seconds during any operation triggered by a manual switch and memory recall operation, stop the motor immediately and set a position ahead of 6 pulses away from the position as the limit position in the driving direction (same for the opposite limit setting). Set position Virtual Limit Setting Conditions Virtual Limit Setting Positions Slide 2 seconds, 6 pulses 6 pulses from restricted position Backrest adjustment (recline) 2 seconds, 155 pulses 155 pulses from restricted position Front tilt 1 second, 6 pulses 6 pulses from restricted position Rear height adjustment 1.5 seconds, 6 pulses 6 pulses from restricted position
- Pulse : A waveform unit to measure revolution of a motor Once a virtual limit has been set, do not perform any memory recall operation to a position out of the limit range, in order to prevent motor damage due to kinematic locking. Renew the limit position if a pulse is normally inputted out of that position by memory manipulation with the limit set.
- Slide recall: When there is no slide motor pulse inputted (mechanical end stop) through 6 or more pulses for 2 seconds during any operation triggered by a manual switch and memory recall operation, stop the motor immediately and set a position ahead of 6 pulses away from the position as the limit position in the driving direction (same for the opposite limit setting). Set position Virtual Limit Setting Conditions Virtual Limit Setting Positions Slide 2 seconds, 6 pulses 6 pulses from restricted position Backrest adjustment (recline) 2 seconds, 155 pulses 155 pulses from restricted position Front tilt 1 second, 6 pulses 6 pulses from restricted position Rear height adjustment 1.5 seconds, 6 pulses 6 pulses from restricted position
- Pulse : A waveform unit to measure revolution of a motor
- Set position Virtual Limit Setting Conditions Virtual Limit Setting Positions
- Slide 2 seconds, 6 pulses 6 pulses from restricted position
- Backrest adjustment (recline) 2 seconds, 155 pulses 155 pulses from restricted position
- Front tilt 1 second, 6 pulses 6 pulses from restricted position
- Rear height adjustment 1.5 seconds, 6 pulses 6 pulses from restricted position
- Once a virtual limit has been set, do not perform any memory recall operation to a position out of the limit

range, in order to prevent motor damage due to kinematic locking.

- Renew the limit position if a pulse is normally inputted out of that position by memory manipulation with the limit set.

- Virtual Limit Setting Procedure Slide : To set a virtual limit, move a seat forwards to the end stop, hold it for 2 seconds, move it rearwards to the end, and then hold it for 2 seconds. Backrest adjustment (recline)

: To set a virtual limit, move a backrest forwards to the end stop, hold it for 2 seconds, move it rearwards to the end, and then hold it for 2 seconds. Front tilt : To set a virtual limit, move a seat upwards to the

end stop, hold it for 1 second, move it downwards to the end, and then hold it for 1 second. Rear height adjustment : To set a virtual limit, move a seat upwards to the end stop, hold it for 1.5 seconds, move it

downwards to the end, and then hold it for 1.5 seconds.

- Slide : To set a virtual limit, move a seat forwards to the end stop, hold it for 2 seconds, move it rearwards to the end, and then hold it for 2 seconds.

- Backrest adjustment (recline) : To set a virtual limit, move a backrest forwards to the end stop, hold it for 2 seconds, move it rearwards to the end, and then hold it for 2 seconds.

- Front tilt : To set a virtual limit, move a seat upwards to the end stop, hold it for 1 second, move it downwards to the end, and then hold it for 1 second.

- Rear height adjustment : To set a virtual limit, move a seat upwards to the end stop, hold it for 1.5 seconds, move it downwards to the end, and then hold it for 1.5 seconds.

- Slide : To set a virtual limit, move a seat forwards to the end stop, hold it for 2 seconds, move it rearwards to the end, and then hold it for 2 seconds.

- Backrest adjustment (recline) : To set a virtual limit, move a backrest forwards to the end stop, hold it for 2 seconds, move it rearwards to the end, and then hold it for 2 seconds.

- Front tilt : To set a virtual limit, move a seat upwards to the end stop, hold it for 1 second, move it downwards to the end, and then hold it for 1 second.

- Rear height adjustment : To set a virtual limit, move a seat upwards to the end stop, hold it for 1.5 seconds, move it downwards to the end, and then hold it for 1.5 seconds.

## IMS (Integrated Memory System) - Schematic Diagrams (Article 44543)

- Components

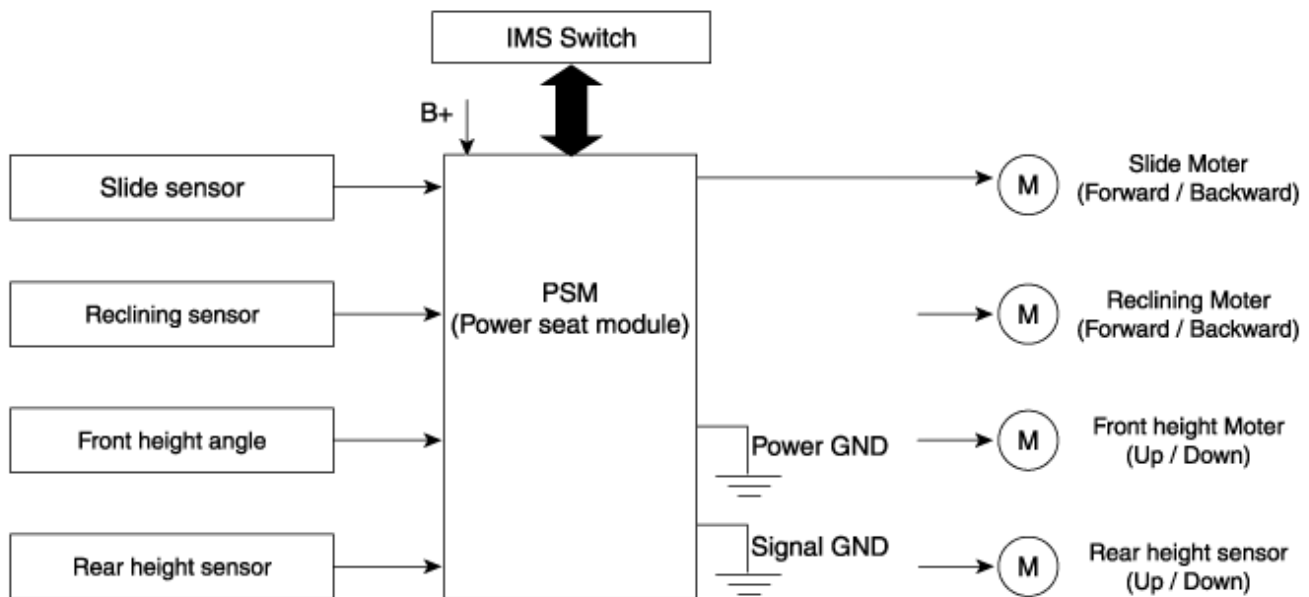

## Integrated Memory System (IMS) - Schematic Diagrams (Article 42514)

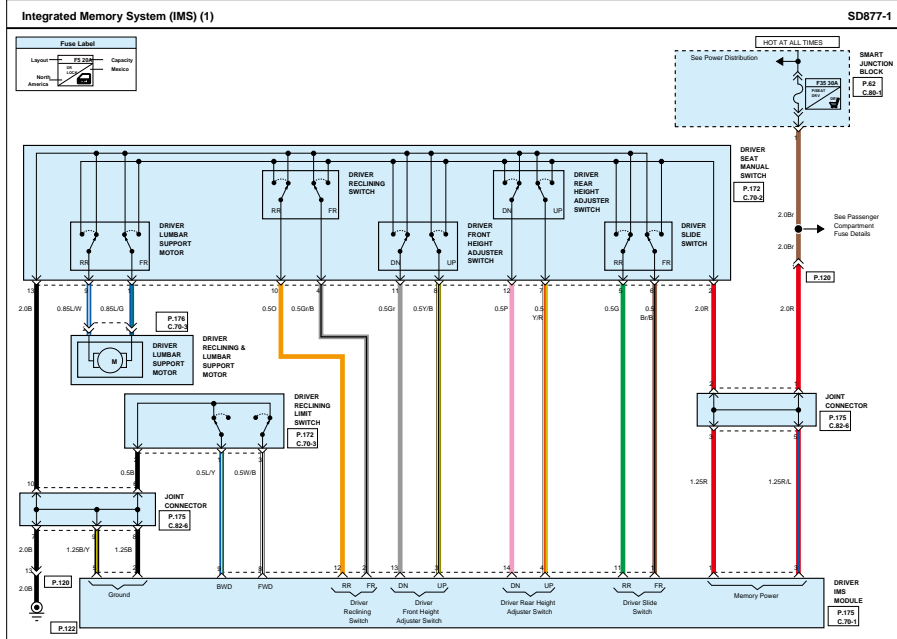

(SD110-10)

(SD120-7)

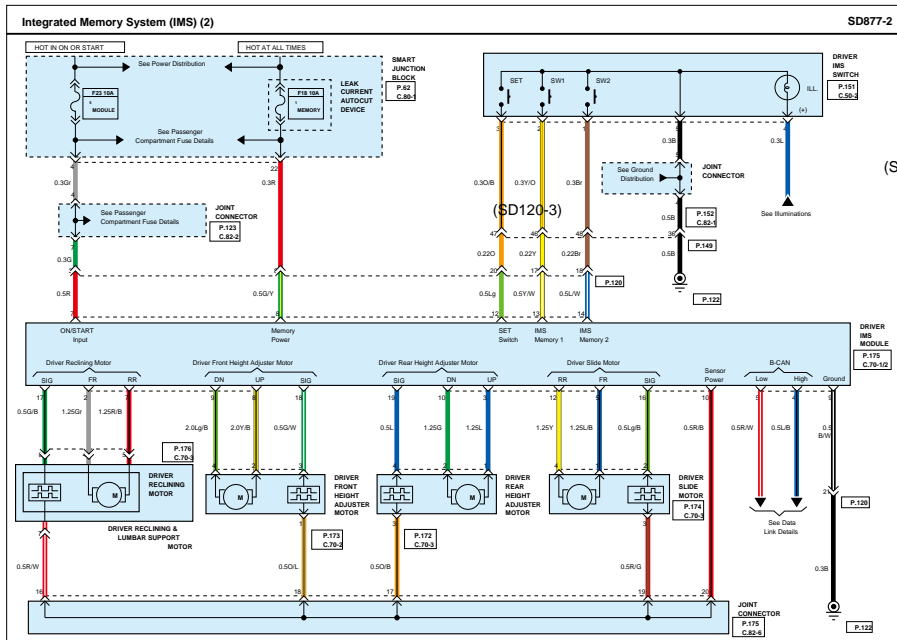

(SD130-6)

(SD941-2)

(SD200-11)

## Memory Systems - Driver's Memory Seat Circuit (Article 10486)

Memory Systems - Driver's Memory Seat Circuit

Page 1 of 2

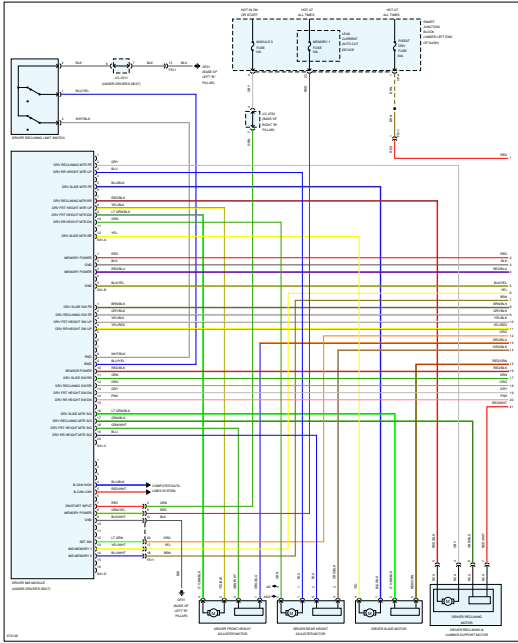

Page 2 of 2

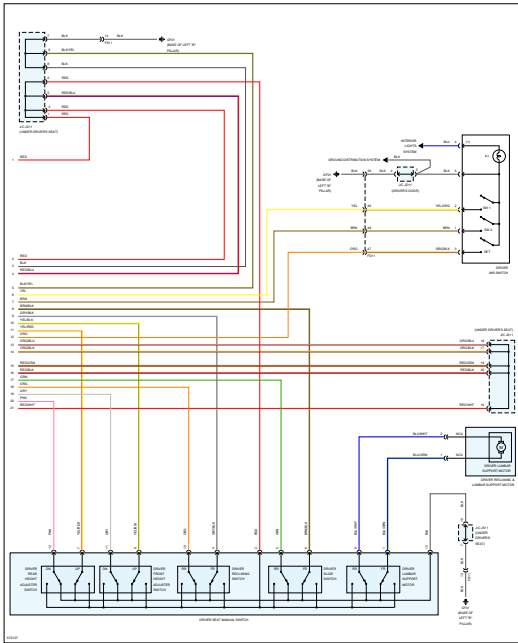

## Memory Systems - Memory Mirrors Circuit (Article 10483)

Memory Systems - Memory Mirrors Circuit

Page 1 of 2

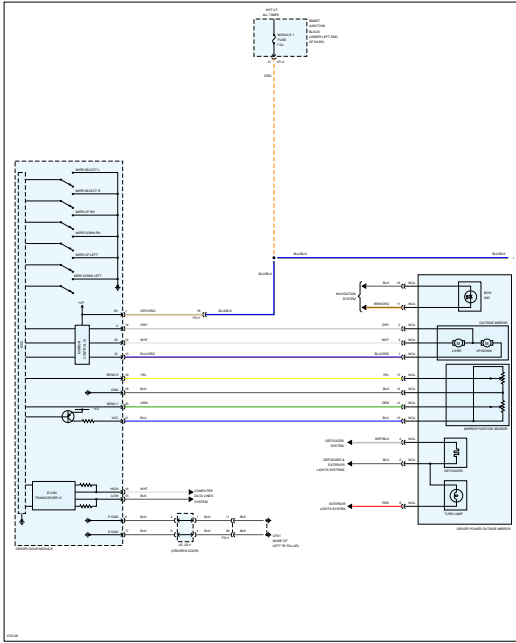

Page 2 of 2

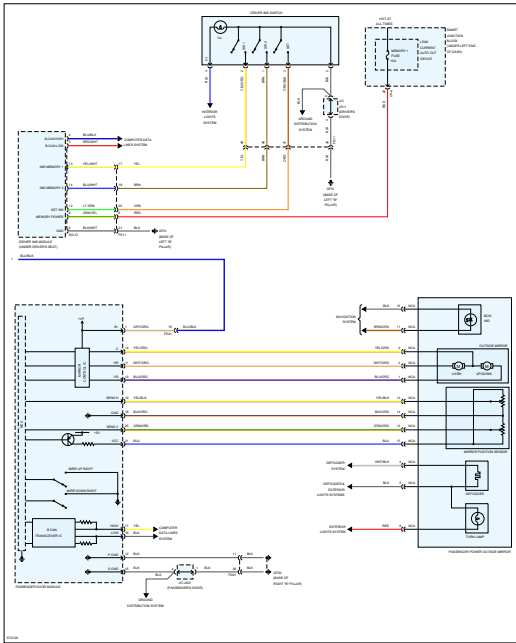

## IMS (Integrated Memory System) - Components and Components Location (Article 44542)

- Components

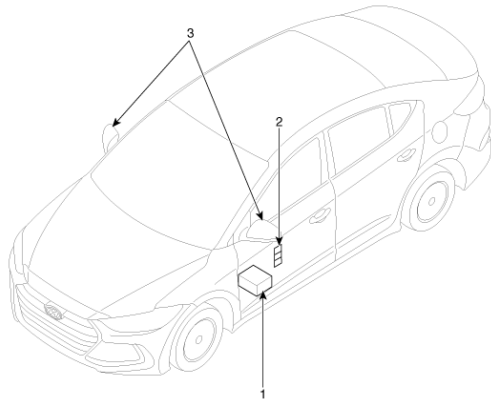

1. Memory power seat unit (PSM) 2. IMS control switch 3. Outside Mirror

### **IMS (Integrated Memory System) - Specifications (Article 44541)**

- Specifications

[Memory Power Seat Unit ]

Item Specifications

Rated voltage DC 12V

Operating Voltage DC 9V - 16V

Operating Temperature Range -30°C - 75°C

Dark current Max. 1mA

[Memory Power Seat Switch ]

Rated voltage DC 5V

Type Soft Feeling Tact type

Operating Temperature Range -30°C - 80°C