

# Component Procedures: Power Steering

## Table of Contents

1. Specifications Quick Reference (itype\_439)
2. Electronic Power Steering (Article 11870)
3. MDPS Assembly - Repair Procedures (Article 44260)
4. MDPS Column and Housing - Repair Procedures (Article 44258)
5. MDPS Control Unit - Repair Procedures (Article 44257)
6. MDPS Motor - Repair Procedures (Article 44256)
7. All Technical Service Bulletins (itype\_100)
8. Noise (itype\_156)

# Component Procedures: Power Steering

## Specifications Quick Reference (itype\_439)

Quick Specifications

- item

## Electronic Power Steering (Article 11870)

Electronic Power Steering

Page 1 of 1

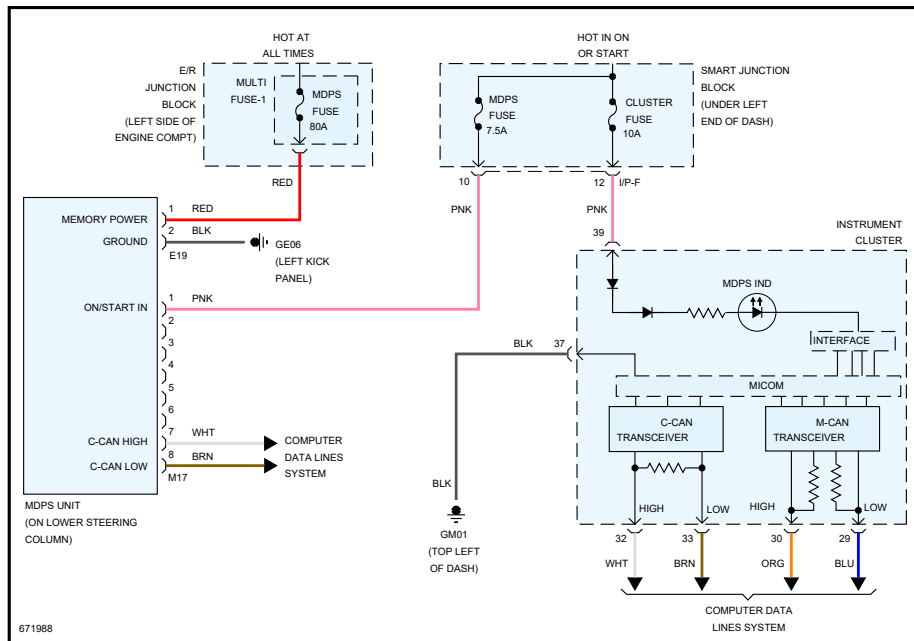

## MDPS Assembly - Repair Procedures (Article 44260)

- Replacement
- Disconnect the battery negative cable from the battery and then wait for at least 30 seconds.
- Turn the steering wheel so that the front wheels are placed in the straight ahead position.
- Remove the driver airbag module (DAB). (Refer to Restraint - "Driver Airbag (DAB) Module and Clock Spring")
- Remove the steering wheel. (Refer to Steering System - "Steering wheel")
- Loosen the screw and then remove the steering column upper (A) and lower shroud (B).

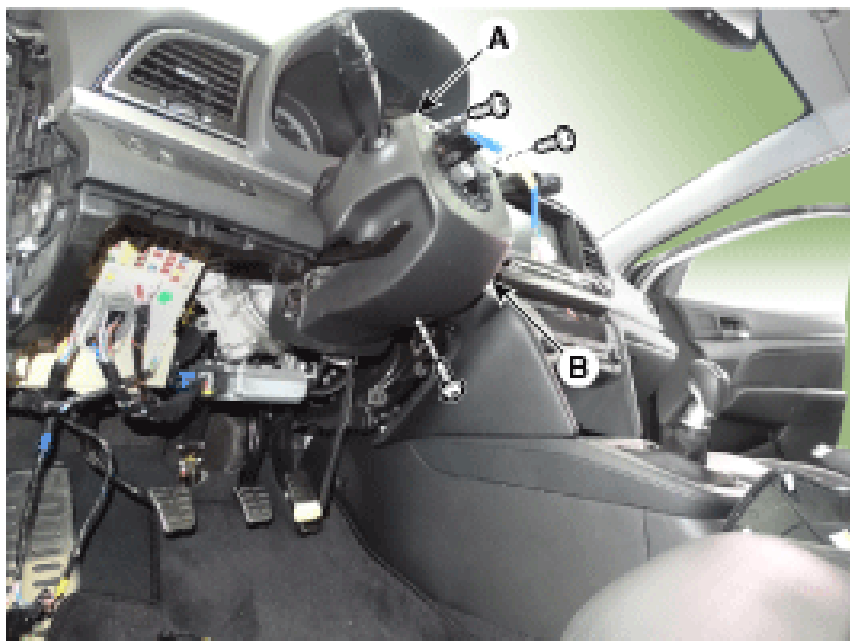

- Remove the clock spring. (Refer to Restraint - "Driver Airbag (DAB) Module and Clock Spring")

- Remove the multifunction switch. (Refer to Body Electrical System - "Multifunction Switch")
- Remove the crash pad lower panel. (Refer to Body - "Crash Pad")
- Remove the fixed clip and then remove the wiring from the steering column.

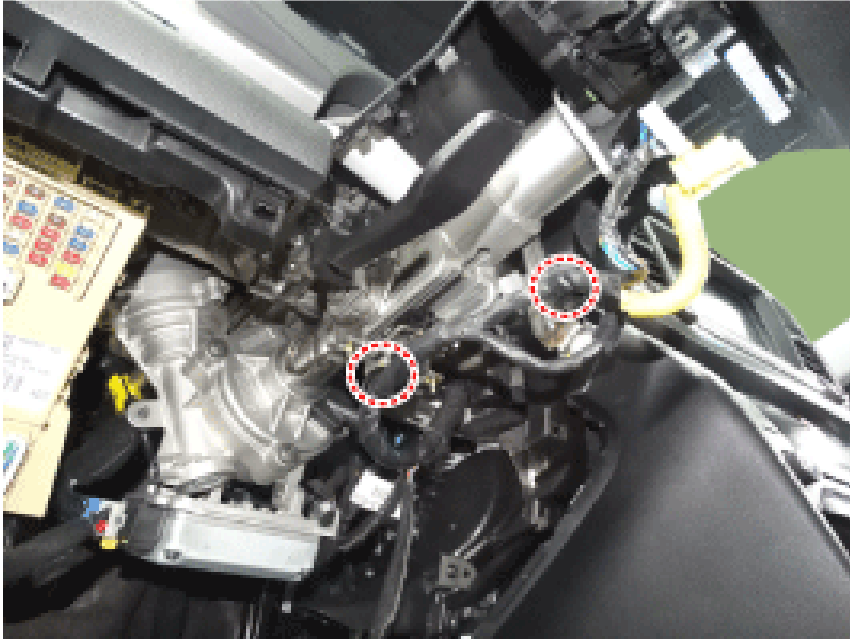

- Disconnect MDPS ECU connector.

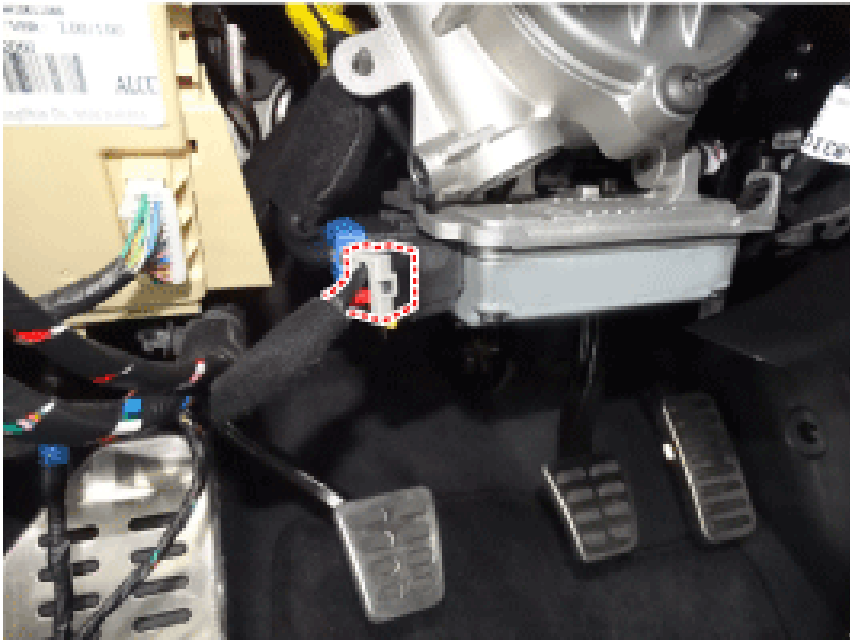

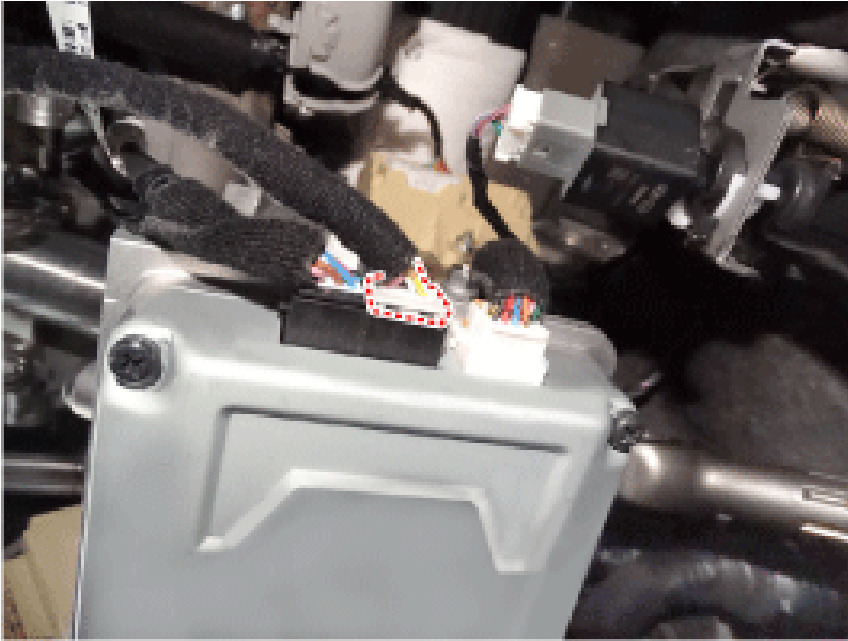

- Loosen the bolt (A) and then disconnect the universal joint assembly from the pinion of the steering gear box . Tightening torque : 32.4 - 37.3 N.m (3.3 - 3.8 kgf.m, 23.9 - 27.5 lb-ft) Keep the steering wheel stationary. Do not reuse the bolt. Lock the steering wheel in the straight ahead position to prevent the damage of the clock spring inner cable. When assembling, insert the shark pin into the universal joint yolk slot as the below illustration.

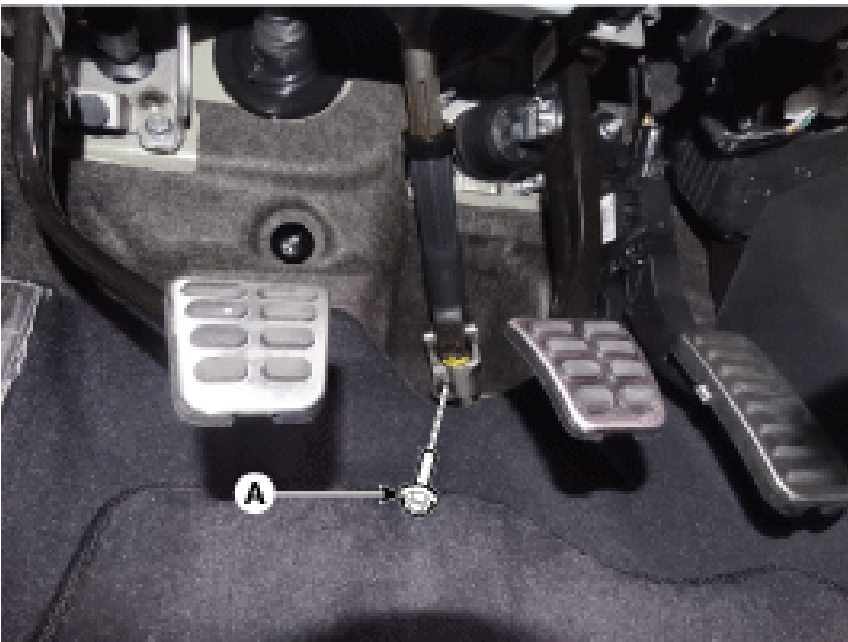

Keep the steering wheel stationary. Do not reuse the bolt. Lock the steering wheel in the straight ahead position to prevent the damage of the clock spring inner cable. When assembling, insert the shark pin into the universal joint yolk slot as the below illustration.

# NOTICE

- Keep the steering wheel stationary.
- Do not reuse the bolt.
- Lock the steering wheel in the straight ahead position to prevent the damage of the clock spring inner cable.
- When assembling, insert the shark pin into the universal joint yolk slot as the below illustration.

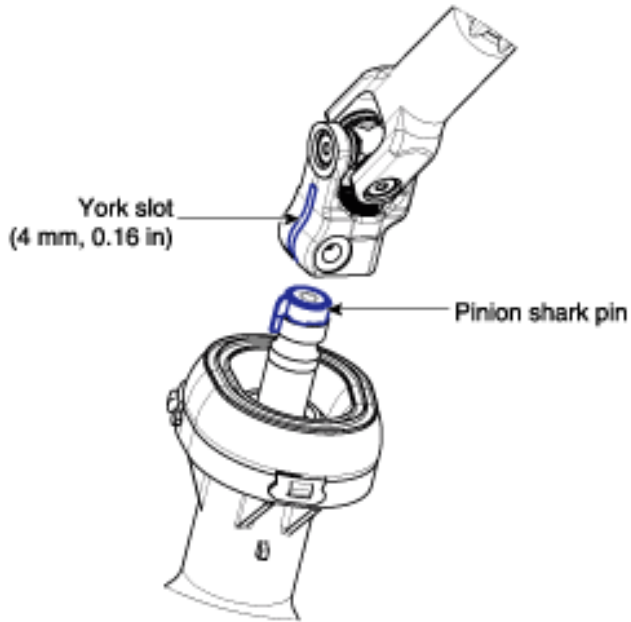

- Remove the steering column ■ EPS unit assembly by loosening the mounting bolt (B) and nuts (A). Tightening torque Nut : 25.0 - 29.4 N.m (2.5 - 3.0 kgf.m, 14.5 - 21.7 lb-ft) Bolt : 44.1 - 49.0 N.m (4.5 - 5.0 kgf.m, 32.5 - 36.2 lb-ft)



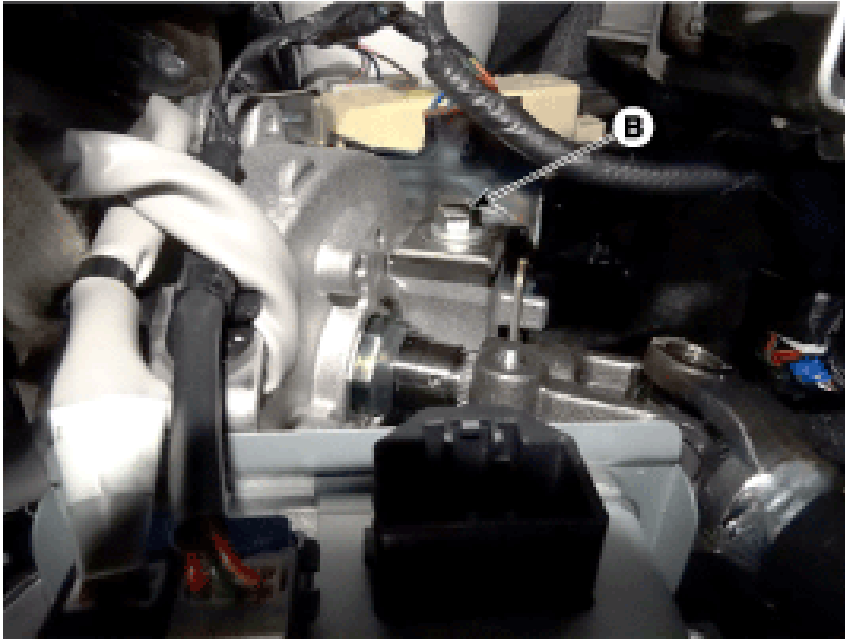

- Install in the reverse order of removal.
  - Conduct the "ASP Calibration" and "EPS Type Recognition" by GDS. (Refer to MDPS Assembly - "Diagnosis with GDS")
  - Conduct the "MDPS TEST (Motor Driven Power Steering )" by GDS. (Refer to Motor Driven Power Steering - "MDPS Performance Inspection")
  - Disassembly
  - Loosen the bolt (A) and then disconnect the universal joint assembly from the steering column assembly.
- Tightening torque : 49.0 - 58.8 N.m (5.0 - 6.0 kgf.m, 39.8 - 43.4 lb-ft)



- To reassembly, reverse the disassembly procedure.
- Reassembly is the reverse of the disassembly. Do not reuse the universal joint bolt. When assembling, match the gear teeth as the below illustration.
- Do not reuse the universal joint bolt. When assembling, match the gear teeth as the below illustration.
- Do not reuse the universal joint bolt. When assembling, match the gear teeth as the below illustration.

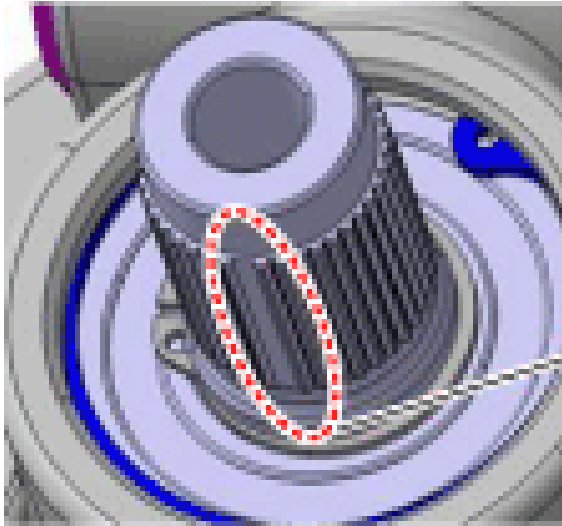

**Column shaft**

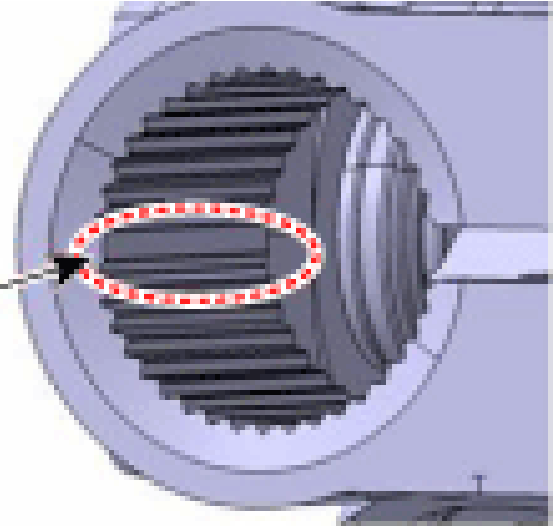

**Universal joint**

- Installation
- Connect self-diagnosis connector(16pins) located in the lower of driver side crash pad to self-diagnosis devic.
- Conduct the "ASP Calibration".

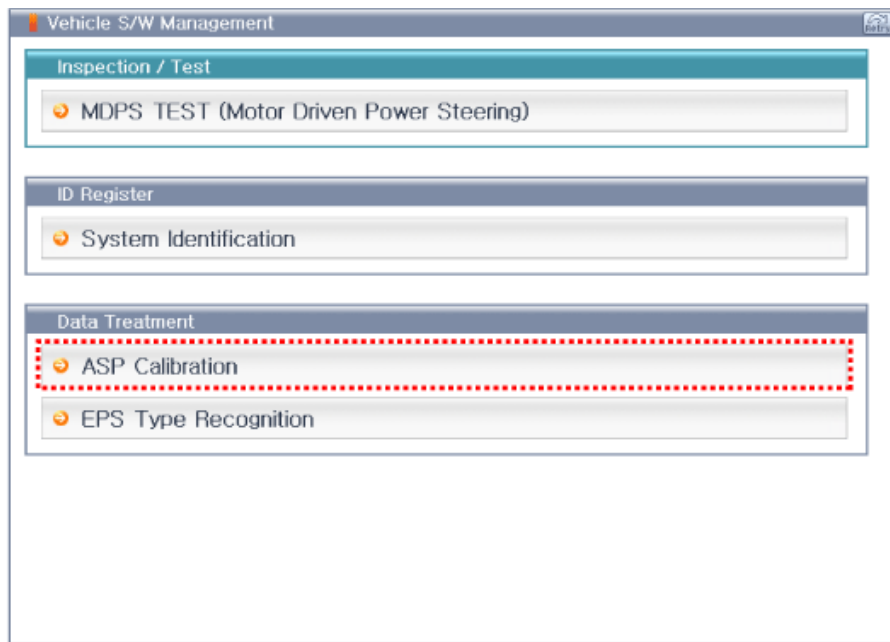

- Conduct the "EPS Type Recognition".

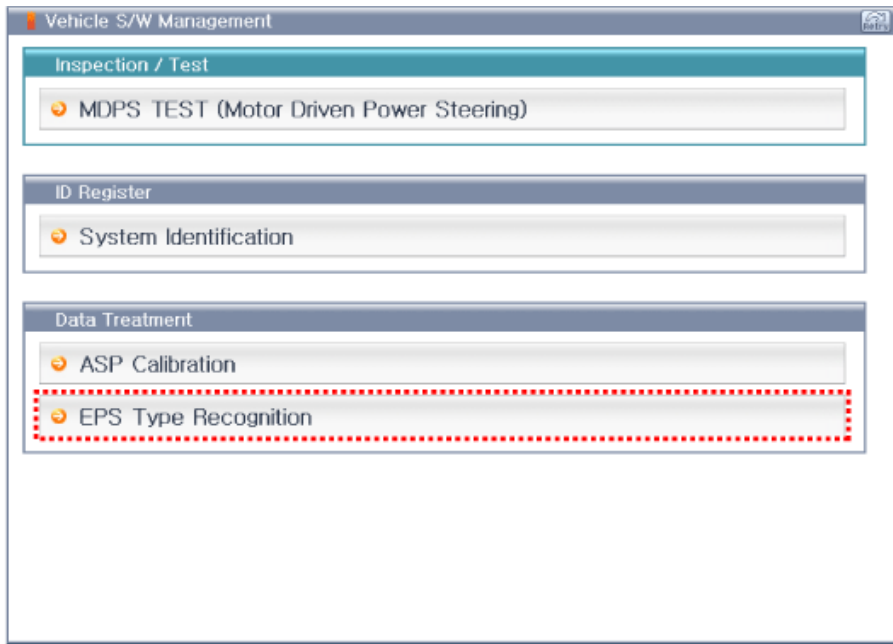

- Inspection

- Check the steering column for damage and deformation.
- Check the joint bearing for damage and wear.
- Check the tilt bracket for damage and cracks.
- Check the key lock assembly for proper operation and replace it if necessary.

- Diagnosis with GDS

ASP Calibration

- Steering-angle sensor detects the steering angle and steering angle speed. Steering angle and steering angle speed are used for steering wheel damping and return controls in addition to providing assistance torque. You can use a scan tool to(GDS) check if the battery voltage is proper before perform the "ASP Calibration". Make sure that no connector engaged to the vehicle or scan tool is disconnected during the "ASP Calibration". Once the "ASP Calibration" is complete, turn off the IG switch and wait for 10 seconds or more before starting the engine to check the operation.
- You can use a scan tool to(GDS) check if the battery voltage is proper before perform the "ASP Calibration".
- Make sure that no connector engaged to the vehicle or scan tool is disconnected during the "ASP Calibration".
- Once the "ASP Calibration" is complete, turn off the IG switch and wait for 10 seconds or more before starting the engine to check the operation.

ASP Calibration procedures

- Connect self-diagnosis connector(16pins) located in the lower of driver side crash pad to self-diagnosis device.
- Turn the self-diagnosis device after key is ON.
- Turn the steering wheel to straight ahead position.
- After Selecting the "vehicle model" and "system", select the "ASP Calibration" on GDS vehicle selection screen.

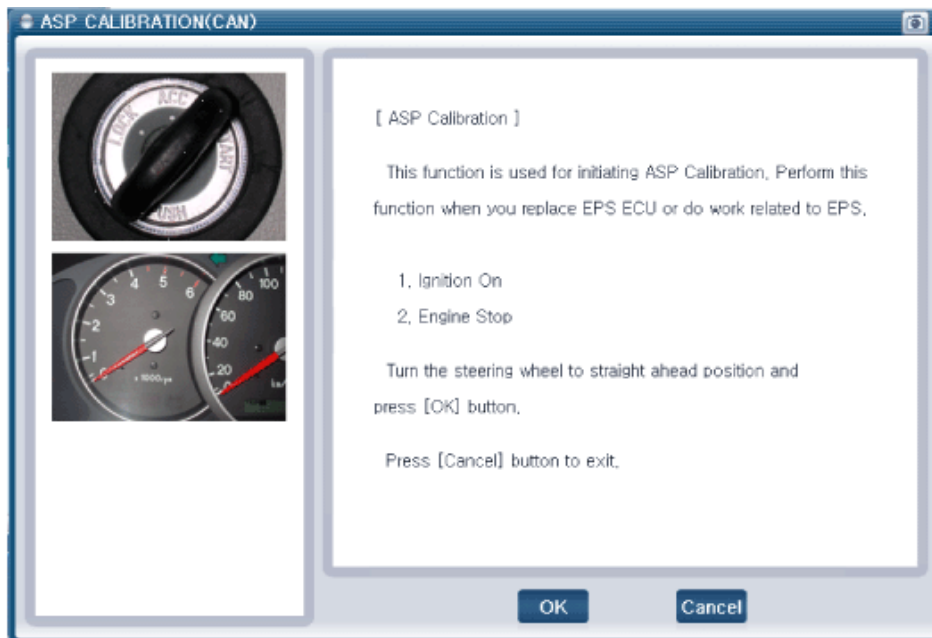
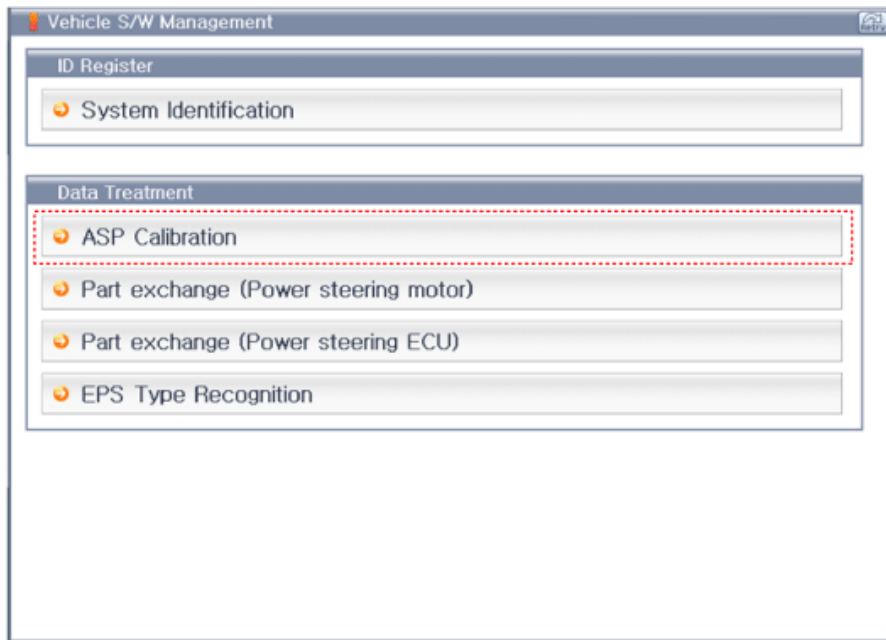

#### EPS Type Recognition

When missing the EPS Type Recognition, occur a problem with motor driven power steering performance.



- When missing the EPS Type Recognition, occur a problem with motor driven power steering performance.

You can use a scan tool to(GDS) check if the battery voltage is proper before perform the "EPS Type Recognition". Make sure that no connector engaged to the vehicle or scan tool is disconnected during the "EPS Type Recognition". Once the "EPS Type Recognition" is complete, turn off the IG switch and wait for 10 seconds or more before starting the engine to check the operation.

- You can use a scan tool to(GDS) check if the battery voltage is proper before perform the "EPS Type

Recognition".

- Make sure that no connector engaged to the vehicle or scan tool is disconnected during the "EPS Type Recognition".

- Once the "EPS Type Recognition" is complete, turn off the IG switch and wait for 10 seconds or more before starting the engine to check the operation.

EPS Type Recognition procedures

- After Selecting the "vehicle model" and "system", select the "EPS Type Recognition" on GDS vehicle selection screen.

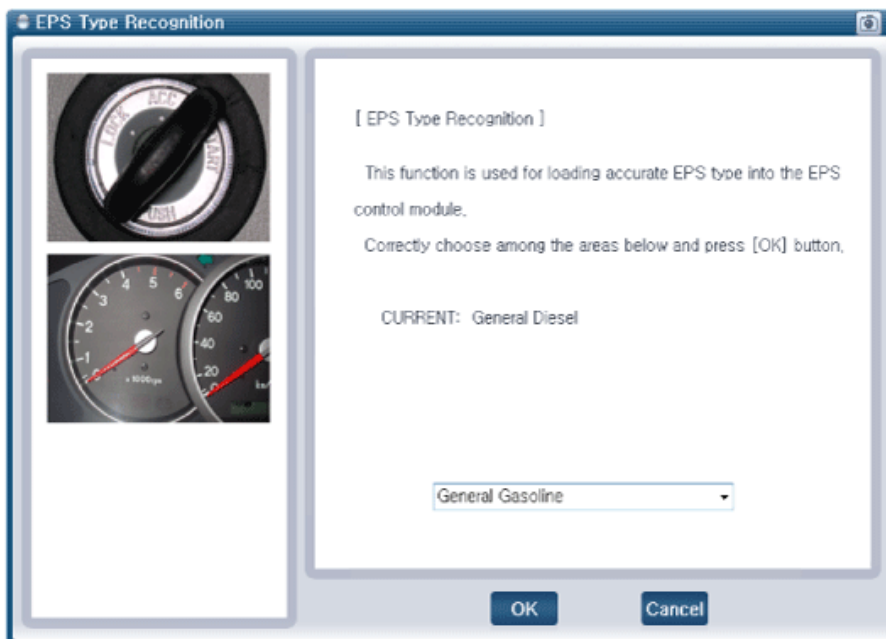
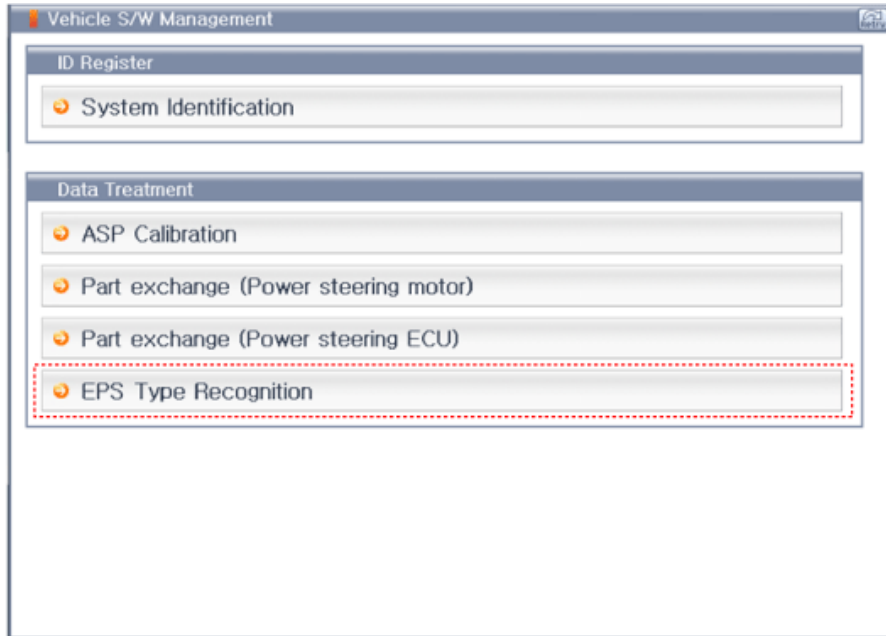

- Remove the DTC.

- Turn off the IG switch and wait for 10 seconds or more before starting the engine. And then make sure that MDPS works properly.

### **MDPS Column and Housing - Repair Procedures (Article 44258)**

- Removal

- Remove the MDPS assembly. (Refer to Steering System - "MDPS Assembly")

- Remove the MDPS control unit. (Refer to Steering System - "MDPS Control Unit")

- Remove the MDPS motor. (Refer to Steering System - "MDPS Motor")

- Installation

- Install in the reverse order of removal.
- Perform "set the steering feel torque to zero" using the GDS.

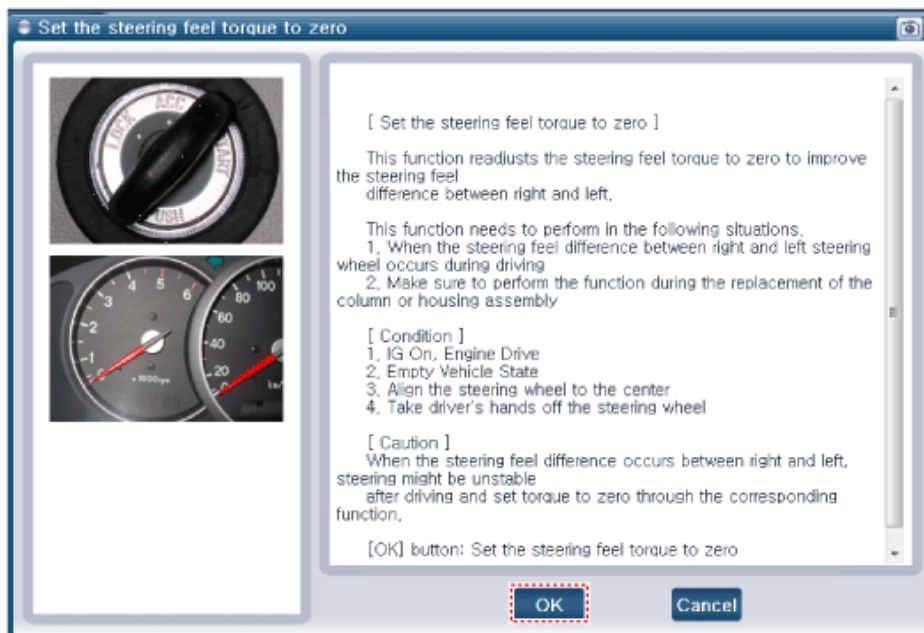

- Conduct the "ASP Calibration" by GDS. (Refer to MDPS Assembly - "Diagnosis with GDS")
- Conduct the "EPS Type Recognition" by GDS. (Refer to MDPS Assembly - "Diagnosis with GDS")
- Check the DTC.
- Turn off the IGN switch and wait for 20 seconds or more. Then check the operation after starting the engine.

### MDPS Control Unit - Repair Procedures (Article 44257)

- Replacement
- If a DTC occurs in the ECU, check the connectors and wiring. If no problem is found, replace the ECU.

# NOTICE

- If a DTC occurs in the ECU, check the connectors and wiring. If no problem is found, replace the ECU.  
Before replacing the MDPS ECU, use the diagnostic device to read the settings of the old ECU

# ⚠ CAUTION

- Before replacing the MDPS ECU, use the diagnostic device to read the settings of the old ECU
- Perform the "ECU data backup" by GDS following in the order below. Connect self-diagnosis connector(16pins) located in the lower of driver side crash pad to self-diagnosis device. Turn the self-diagnosis device after key is ON. After Selecting the "vehicle model" and "EPS system" on GDS vehicle selection screen. Select the "Part exchange( Power steering ECU)" Follow the instructions shown on the screen. Insert the VIN number and then select the "Read" in order to the ECU information save.
- Connect self-diagnosis connector(16pins) located in the lower of driver side crash pad to self-diagnosis device.
- Turn the self-diagnosis device after key is ON.
- After Selecting the "vehicle model" and "EPS system" on GDS vehicle selection screen.
- Select the "Part exchange( Power steering ECU)"

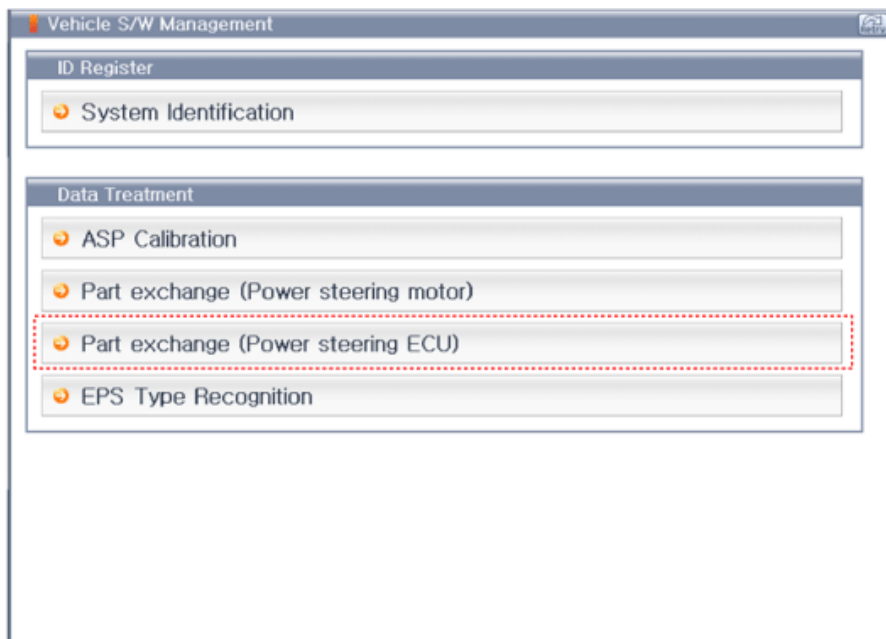

- Follow the instructions shown on the screen.

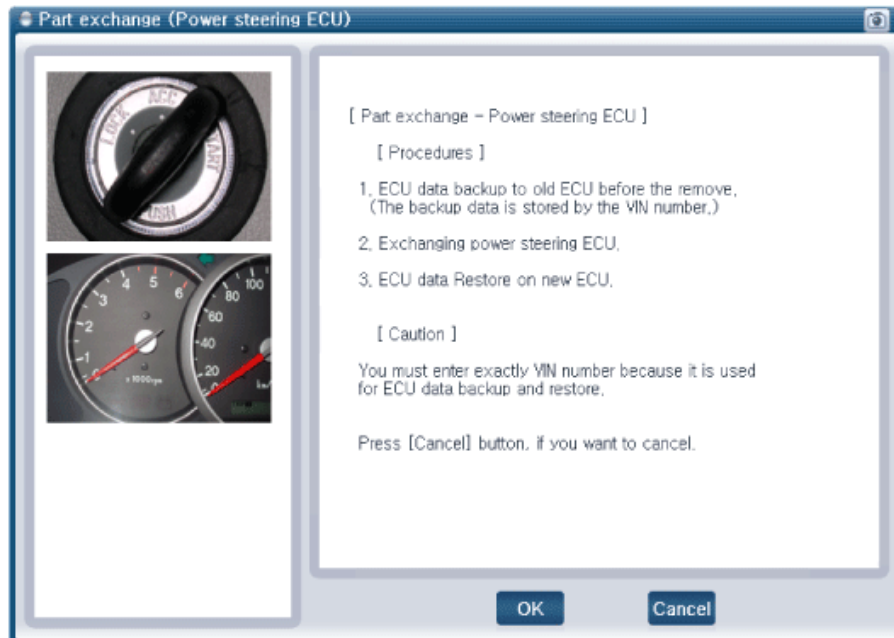
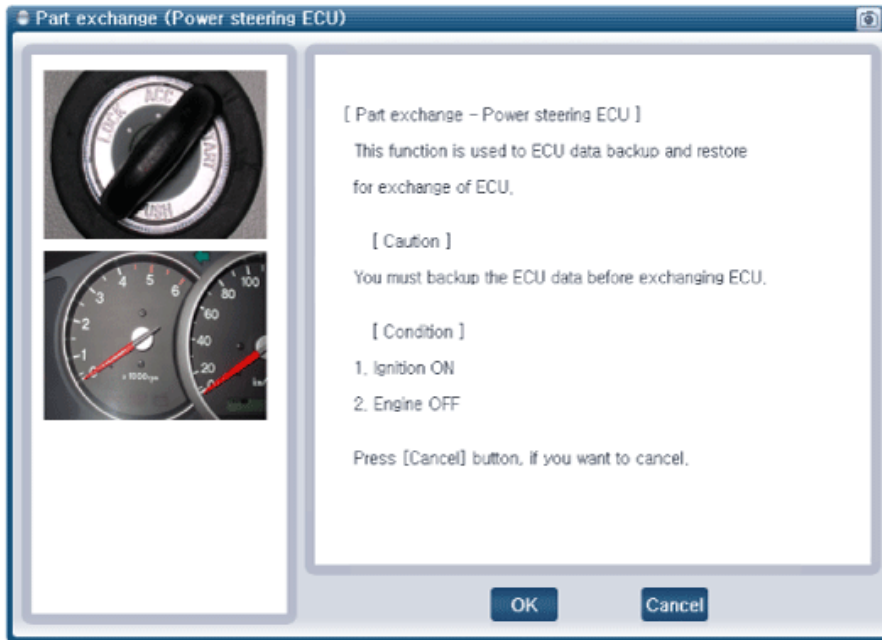

- Insert the VIN number and then select the "Read" in order to the ECU information save.

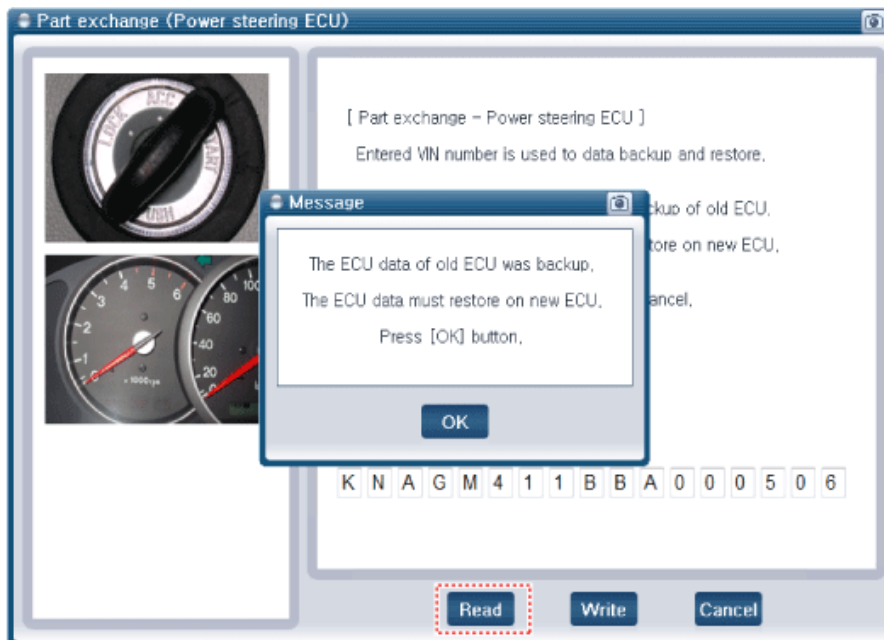
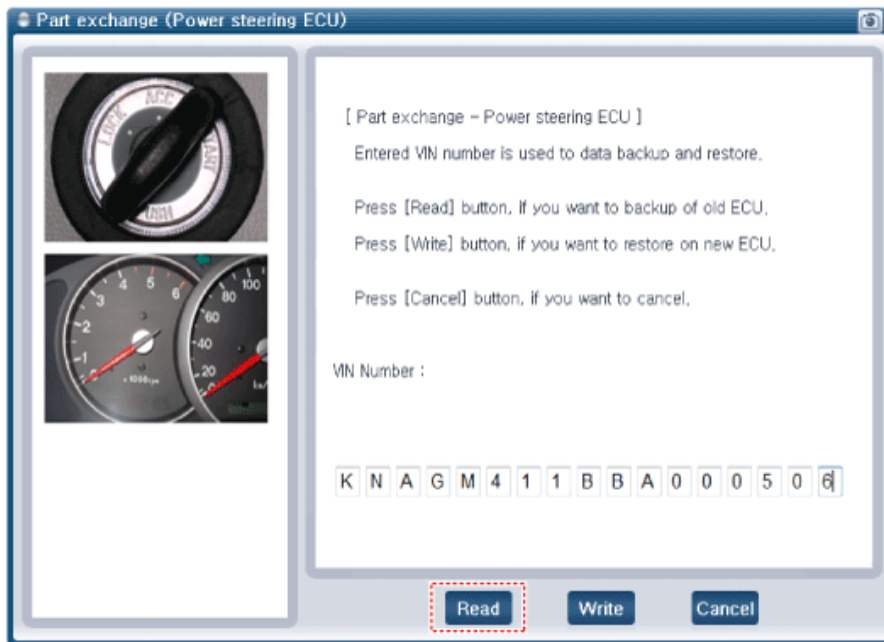

- Disconnect the battery negative cable from the battery and then wait for at least 30 seconds.
- Remove the crash pad lower panel. (Refer to Body - "Crash Pad Lower Panel")
- Disconnect the connector from the MDPS control unit.

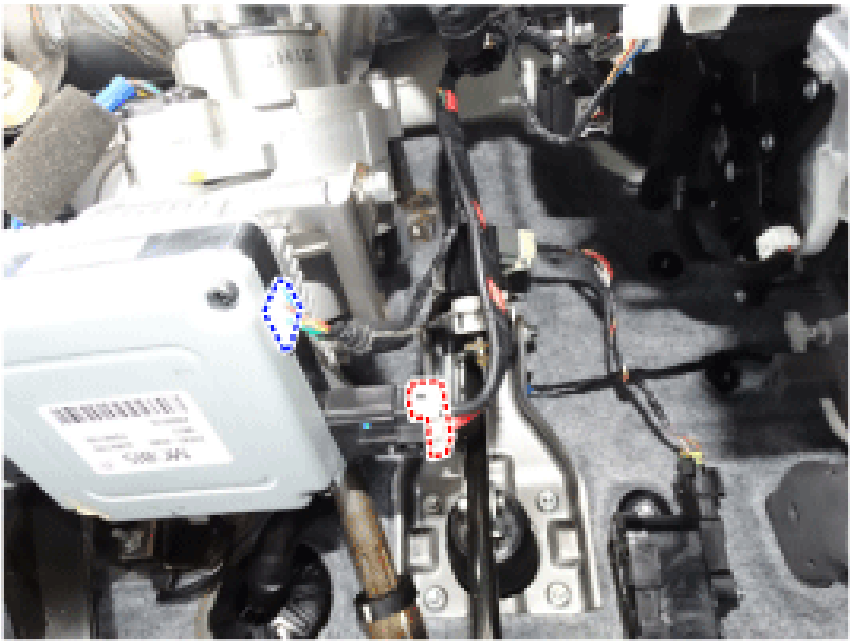
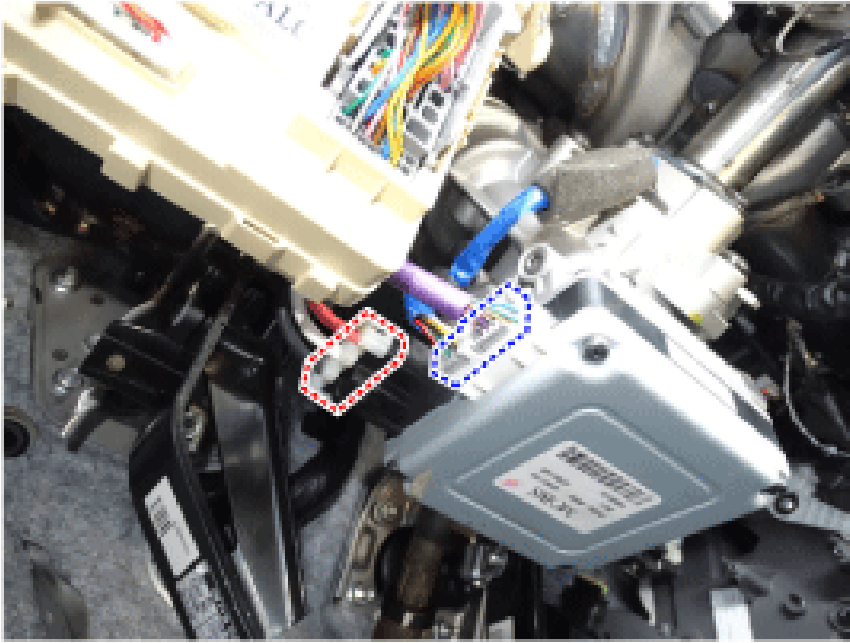

- Remove the MDPS control unit from the steering column after loosening the bolts.

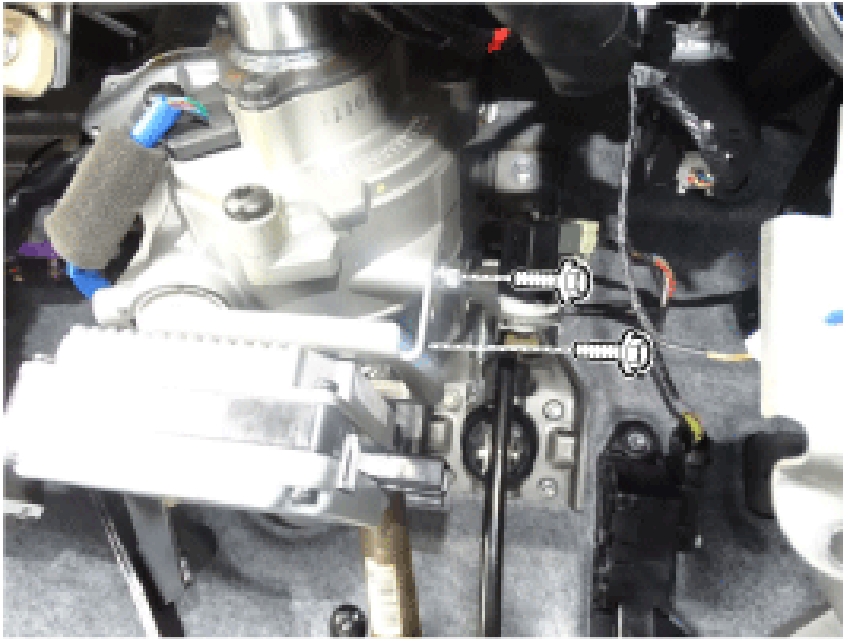

- Replace the MDPS control unit after separating the bracket.

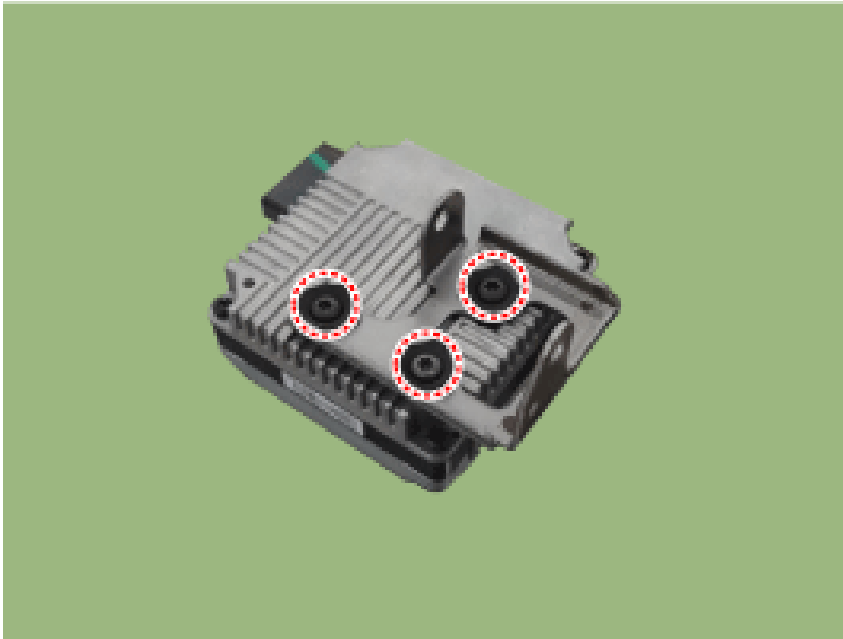

- Install in the reverse order of removal.
- Install the connector to the MDPS control unit.
- Perform the "ECU data restore" by GDS following in the order below. Connect self-diagnosis connector(16pins) located in the lower of driver side crash pad to self-diagnosis device. Turn the self-diagnosis device after key is ON. After Selecting the "vehicle model" and "EPS system" on GDS vehicle selection screen. Select the "Part exchange(Power steering ECU)" Follow the instructions shown on the screen. Insert the VIN number and then select the "Write" in order to the ECU information save.
- Select the "Part exchange(Power steering ECU)"
- Insert the VIN number and then select the "Write" in order to the ECU information save.

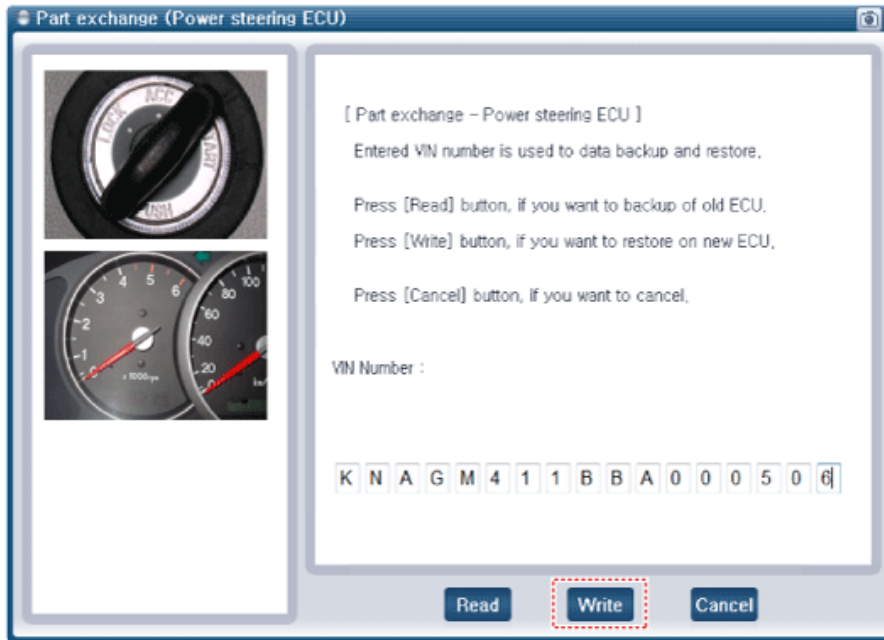

- Conduct the "ASP Calibration" by GDS. (Refer to MDPS Control Unit- "Diagnosis with GDS")
- Remove the DTC and then perform the Conduct the "MDPS TEST (Motor Driven Power Steering)" by GDS. (Refer to Motor Driven Power Steering - "MDPS Performance Inspection")
- Turn off the IGN switch and wait for 10 seconds or more. Then check the operation after starting the engine.
- Diagnosis with GDS
- Steering-angle sensor detects the steering angle and steering angle speed. Steering angle and steering angle speed are used for steering wheel damping and return controls in addition to providing assistance torque. You can use a scan tool to(GDS) check if the battery voltage is proper before perform the "ASP Calibration". Make sure that no connector engaged to the vehicle or scan tool is disconnected during the "ASP Calibration". Once the "ASP Calibration" is complete, turn off the IG switch and wait for 10 seconds or more before starting the engine to check the operation.
- You can use a scan tool to(GDS) check if the battery voltage is proper before perform the "ASP Calibration".
- Make sure that no connector engaged to the vehicle or scan tool is disconnected during the "ASP Calibration".
- Once the "ASP Calibration" is complete, turn off the IG switch and wait for 10 seconds or more before starting the engine to check the operation.
- ASP Calibration procedures
- Turn the steering wheel to straight ahead position.
- After Selecting the "vehicle model" and "system", select the "ASP Calibration" on GDS vehicle selection screen.

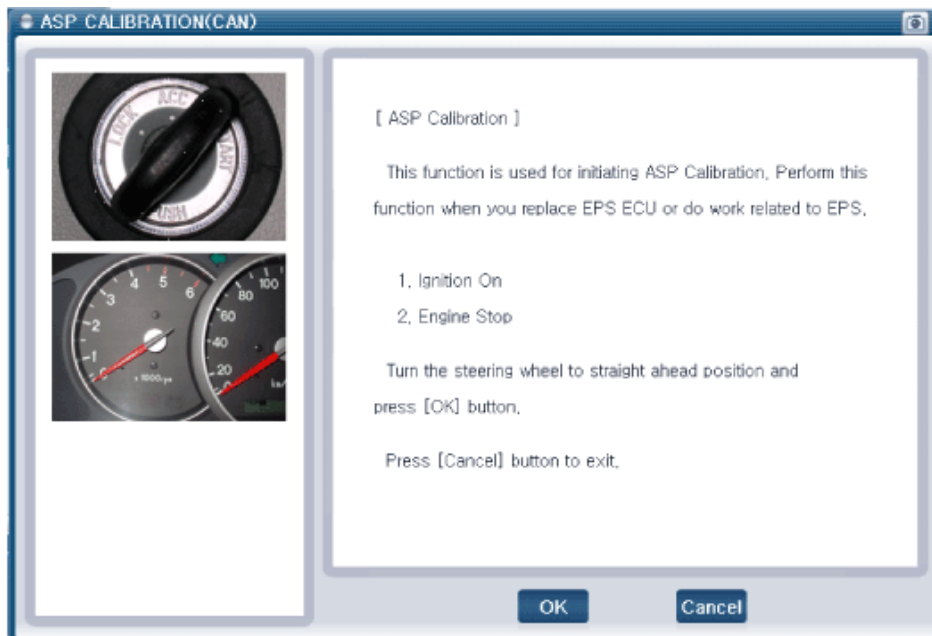
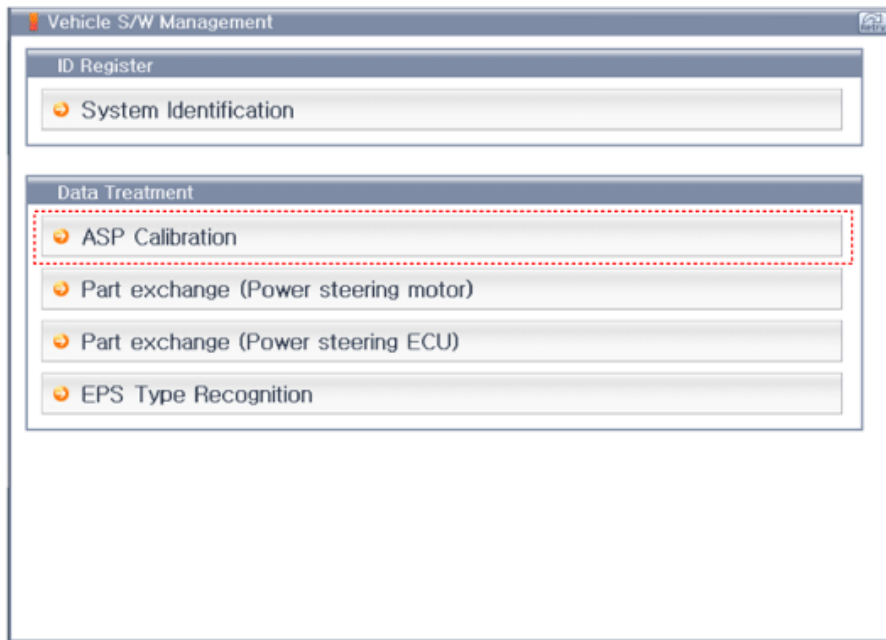

- Remove the DTC.
- Turn off the IG switch and wait for 10 seconds or more before starting the engine. And then make sure that MDPS works properly.

### **MDPS Motor - Repair Procedures (Article 44256)**

- Replacement
- When a DTC related to MDPS motor occurs, check the connectors and wiring. If no problem is found, replace the motor.

# NOTICE

- When a DTC related to MDPS motor occurs, check the connectors and wiring. If no problem is found, replace the motor.

Be sure to check the last two digits of the constant in the barcode of new MDPS motor before replacing the motor. Entering incorrect motor constant value may cause a serious problem in the MDPS.

# ⚠ CAUTION

- Be sure to check the last two digits of the constant in the barcode of new MDPS motor before replacing the motor.

- Entering incorrect motor constant value may cause a serious problem in the MDPS.
- Disconnect the battery negative cable from the battery and then wait for at least 30 seconds.
- Turn the steering wheel so that the front wheels are placed in the straight ahead position.
- Remove the driver airbag module (DAB). (Refer to Restraint - "Driver Airbag (DAB) Module and Clock Spring")
- Remove the steering wheel. (Refer to Steering System - "Steering wheel")
- Loosen the screw and then remove the steering column upper (A) and lower shroud (B).

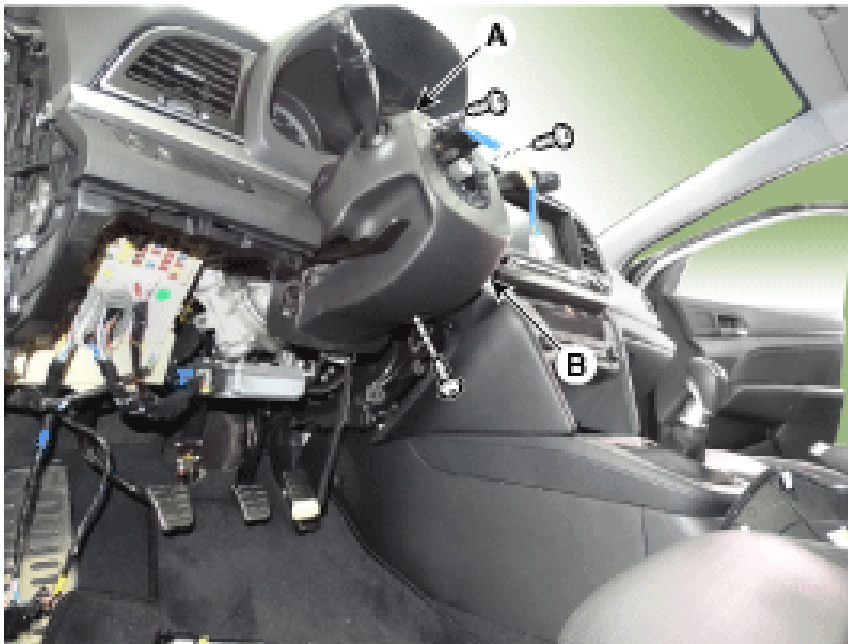

- Remove the clock spring. (Refer to Restraint - "Driver Airbag (DAB) Module and Clock Spring")
- Remove the multifunction switch. (Refer to Body Electrical System - "Multifunction Switch")
- Remove the crash pad lower panel. (Refer to Body - "Crash Pad")
- Remove the fixed clip and then remove the wiring from the steering column.

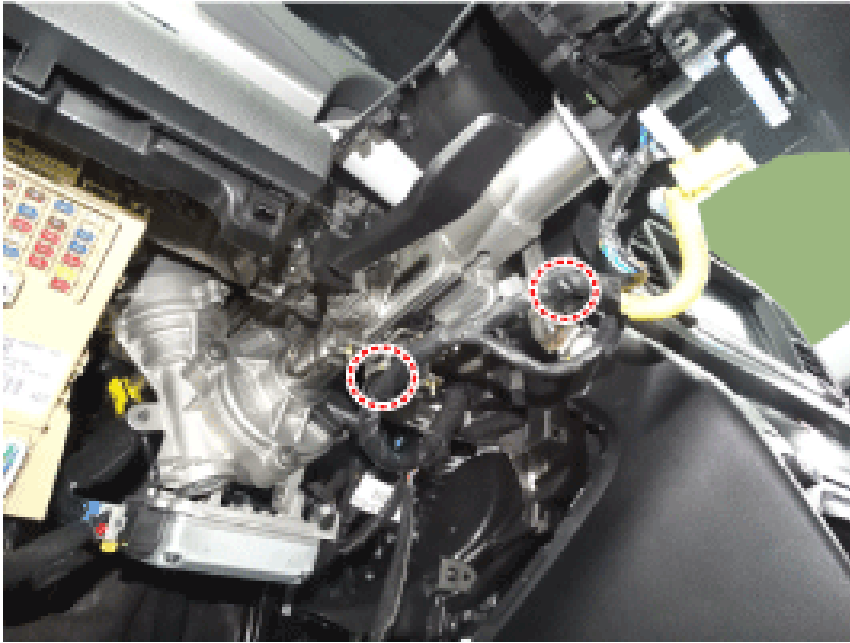

- Disconnect MDPS ECU connector.

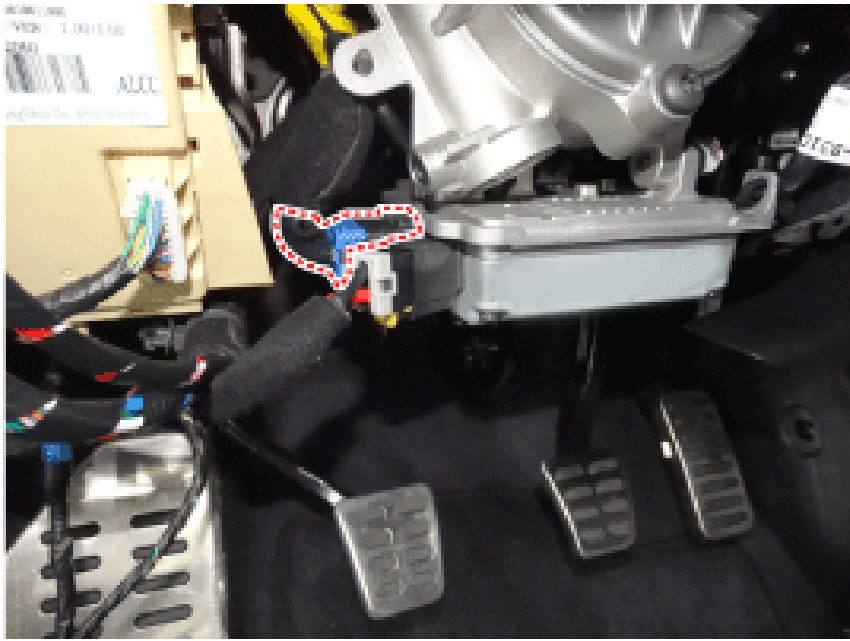

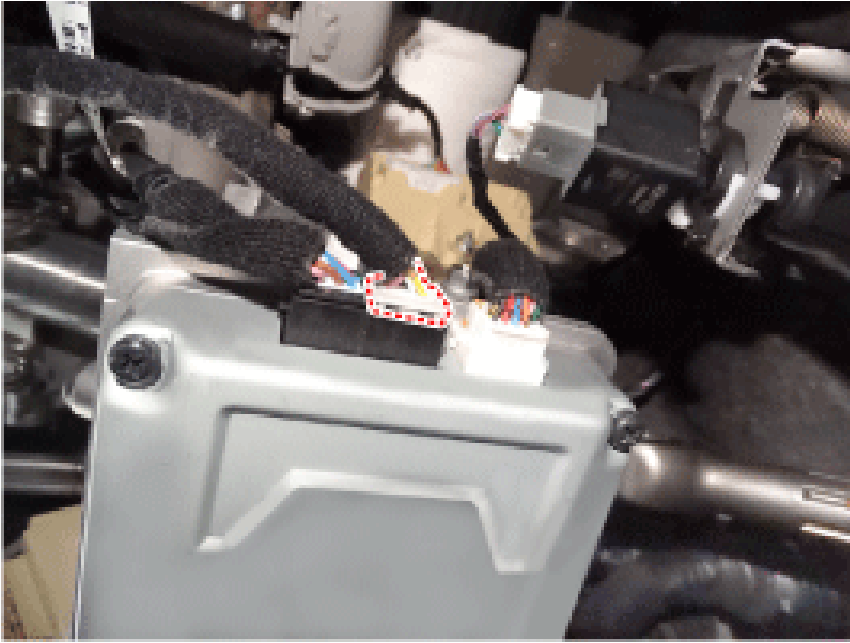

- Remove the steering column ■ EPS unit assembly by loosening the mounting bolt (B) and nuts (A). Tightening torque Nut : 25.0 - 29.4 N.m (2.5 - 3.0 kgf.m, 14.5 - 21.7 lb-ft) Bolt : 44.1 - 49.0 N.m (4.5 - 5.0 kgf.m, 32.5 - 36.2 lb-ft)

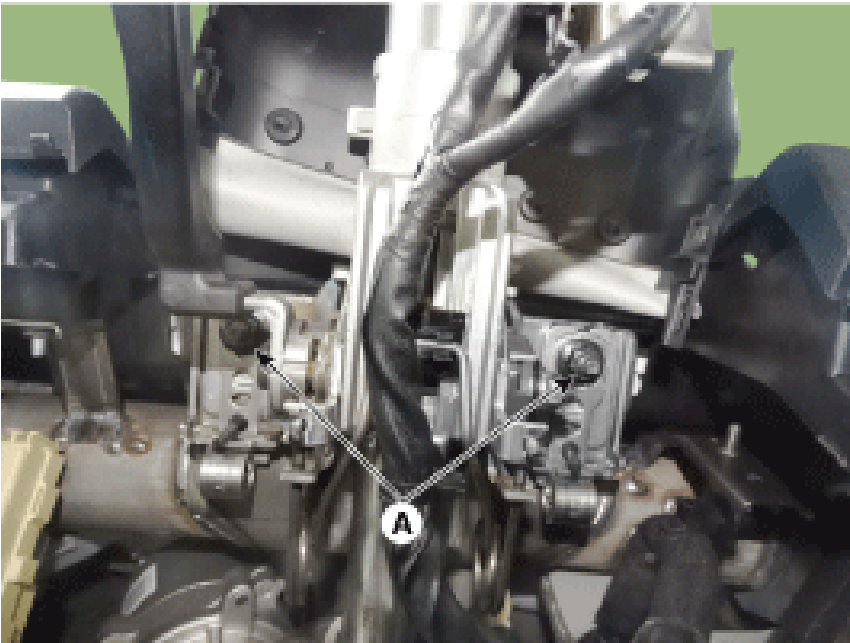

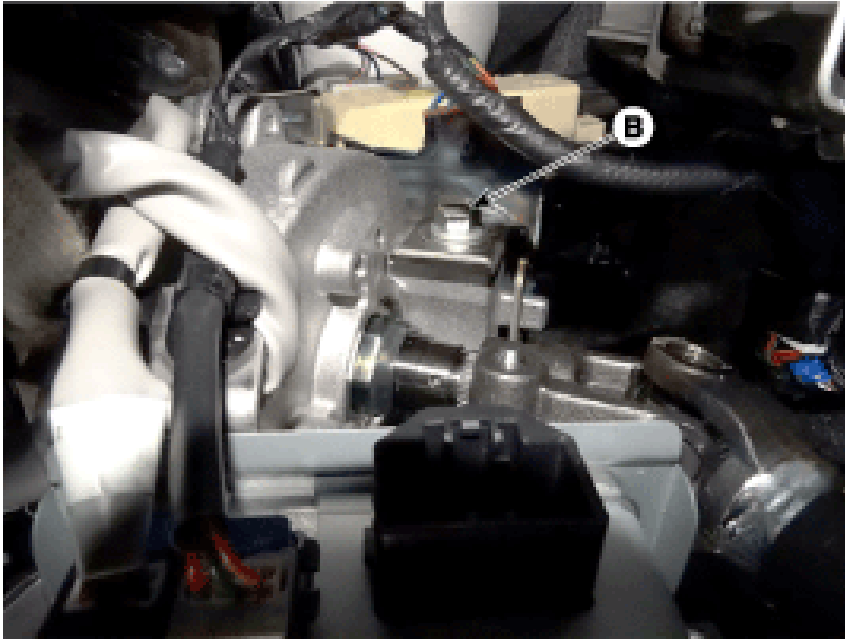

- Remove the motor by loosening the bolts and then replace the new one.



- Install in the reverse order of removal.

- Perform the "Inputting the motor constant value" by GDS following in the order below. Connect self-diagnosis connector(16pins) located in the lower of driver side crash pad to self-diagnosis device. Turn the self-diagnosis device after key is ON. Select the "vehicle model" and "EPS system" on GDS vehicle selection screen. Select the "Part exchange( Power steering Motor )". Follow the instructions shown on the screen. Entering incorrect motor constant value may cause a serious problem in the MDPS.

- Connect self-diagnosis connector(16pins) located in the lower of driver side crash pad to self-diagnosis device.

- Turn the self-diagnosis device after key is ON.

- Select the "vehicle model" and "EPS system" on GDS vehicle selection screen.

- Select the "Part exchange( Power steering Motor )".

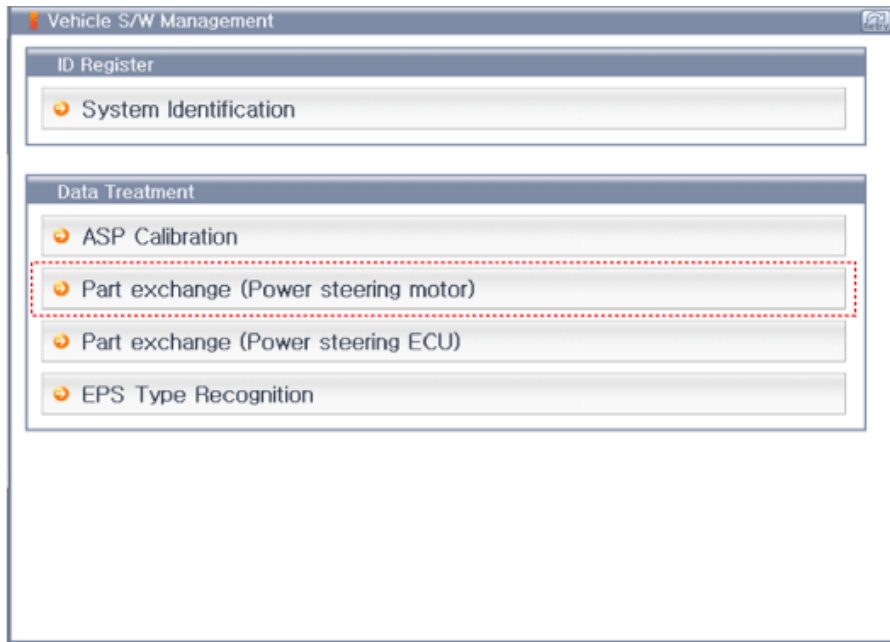

- Follow the instructions shown on the screen. Entering incorrect motor constant value may cause a serious problem in the MDPS.

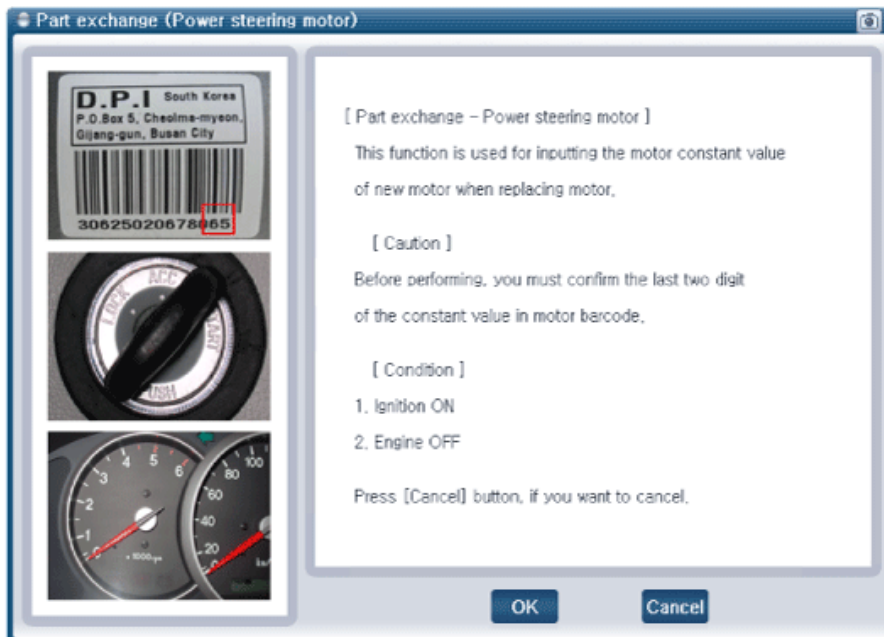

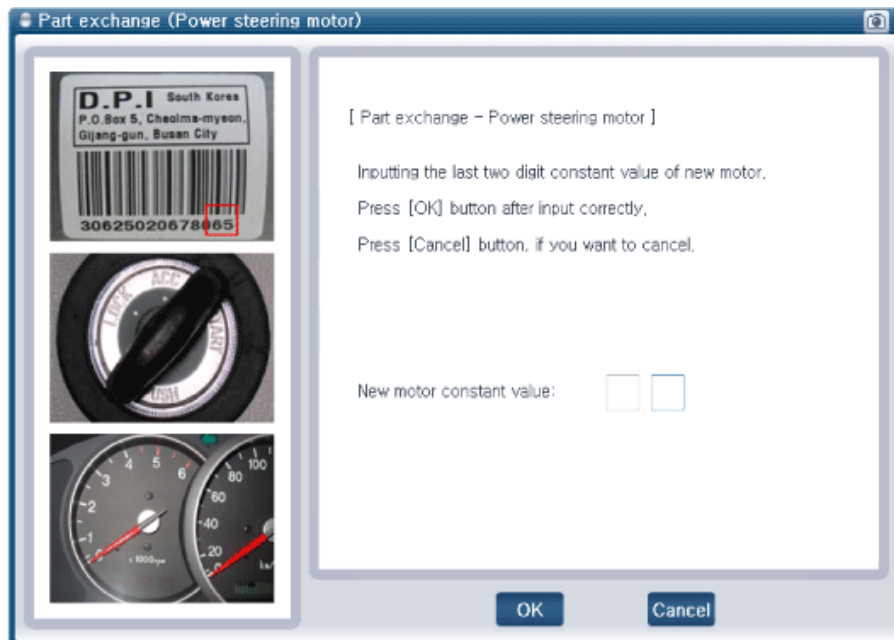
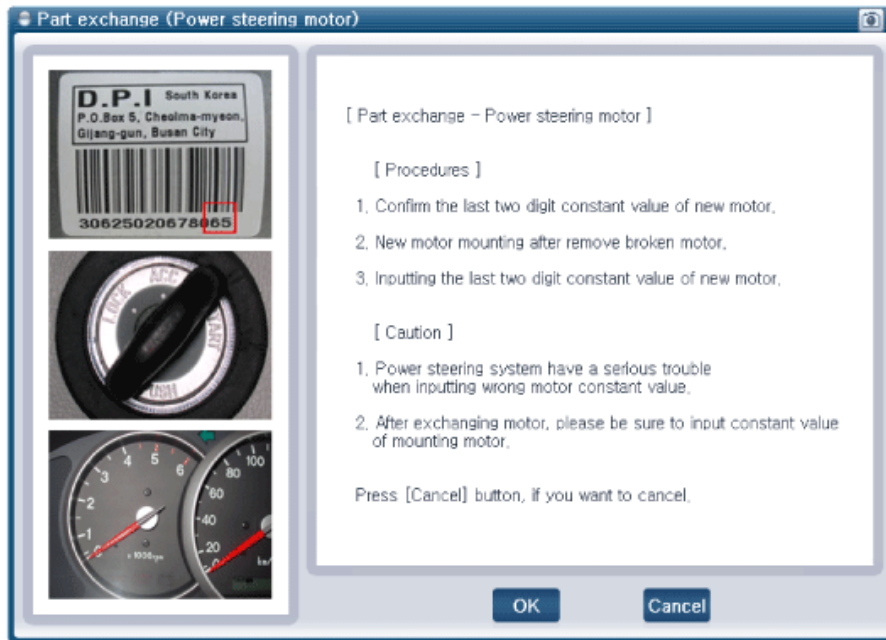

Entering incorrect motor constant value may cause a serious problem in the MDPS.

- Conduct the "ASP Calibration" by GDS. (Refer to MDPS Motor- "Diagnosis with GDS")
- Remove the DTC and then perform the Conduct the "MDPS TEST (Motor Driven Power Steering)" by GDS. (Refer to Motor Driven Power Steering - "MDPS Performance Inspection")
- Turn off the IGN switch and wait for 10 seconds or more. Then check the operation after starting the engine.
- Diagnosis with GDS
- Steering-angle sensor detects the steering angle and steering angle speed. Steering angle and steering angle speed are used for steering wheel damping and return controls in addition to providing assistance torque. You can use a scan tool to(GDS) check if the battery voltage is proper before perform the "ASP Calibration". Make sure that no connector engaged to the vehicle or scan tool is disconnected during the "ASP Calibration". Once the "ASP Calibration" is complete, turn off the IG switch and wait for 10 seconds or more before starting the engine to check the operation.
- You can use a scan tool to(GDS) check if the battery voltage is proper before perform the "ASP Calibration".
- Make sure that no connector engaged to the vehicle or scan tool is disconnected during the "ASP Calibration".
- Once the "ASP Calibration" is complete, turn off the IG switch and wait for 10 seconds or more before starting the engine to check the operation.

ASP Calibration procedures

- Turn the steering wheel to straight ahead position.
- After Selecting the "vehicle model" and "system", select the "ASP Calibration" on GDS vehicle selection screen.

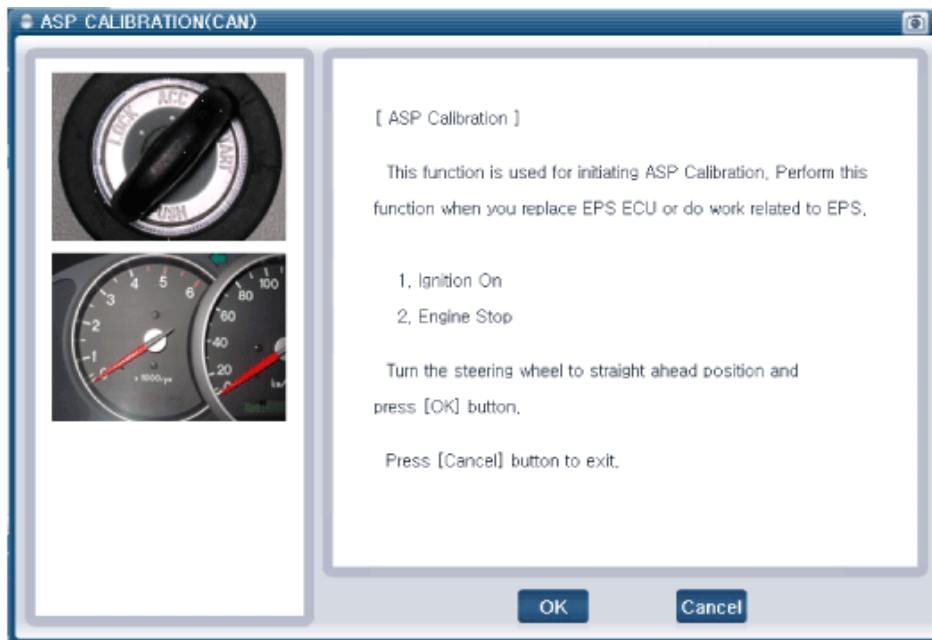
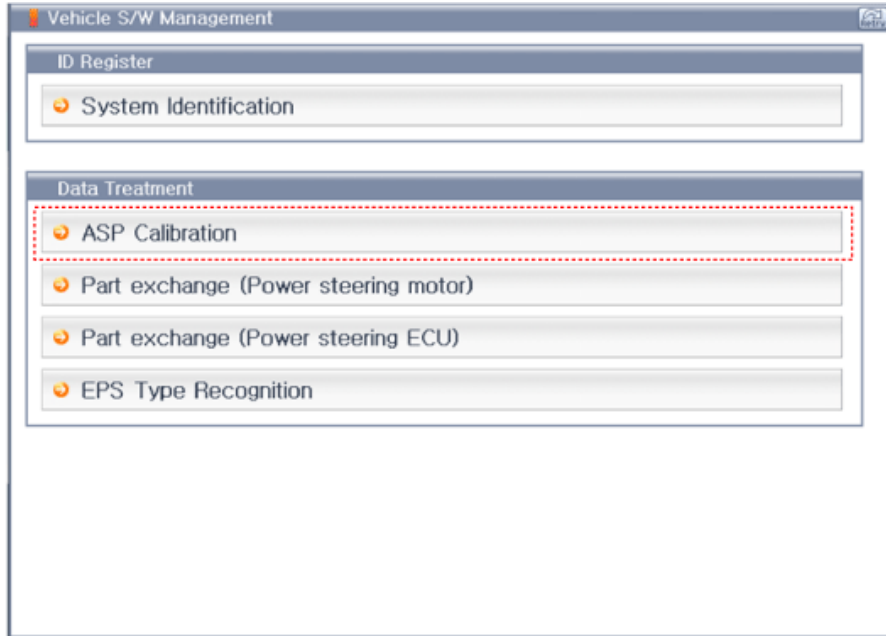

- Remove the DTC.
- Turn off the IG switch and wait for 10 seconds or more before starting the engine. And then make sure that MDPS works properly.

### All Technical Service Bulletins (itype\_100)

Tsbs

- COLUMN-MOUNTED MDPS REPAIR INFORMATION (22-ST-002H, 2022/01/06)
- C-MDPS WORM SHAFT BEARING NOISE (22-ST-004H, 2022/04/04)

### Noise (itype\_156)

Tsbs

- C-MDPS WORM SHAFT BEARING NOISE (22-ST-004H, 2022/04/04)