

Component Procedures: Canister Purge Control Valve

Table of Contents

1. Parts and Labor (itype_189)
2. Purge Control Solenoid Valve (PCSV) - Description and Operation (Article 44151)
3. Purge Control Solenoid Valve (PCSV) - Schematic Diagrams (Article 44154)
4. Purge Control Solenoid Valve (PCSV) - Repair Procedures (Article 44156)
5. Purge Control Solenoid Valve (PCSV) - Specifications (Article 44152)

Component Procedures: Canister Purge Control Valve

Parts and Labor (itype_189)

Parts

Qualifier	Part #	Name	Price	Note
Vapor Canister > Valve	31430F3500	Canister Valve	257.29	

Purge Control Solenoid Valve (PCSV) - Description and Operation (Article 44151)

- Description

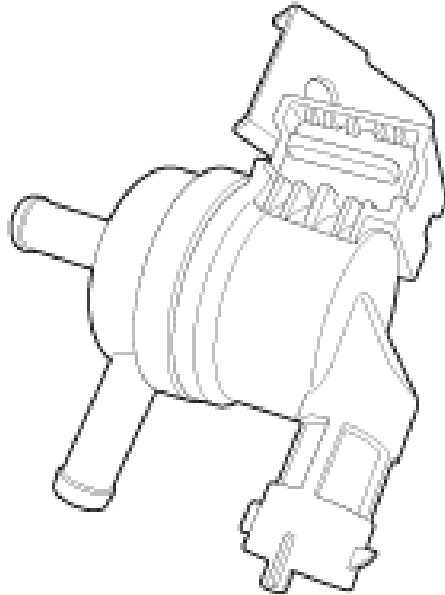

Purge Control Solenoid Valve (PCSV) - Schematic Diagrams (Article 44154)

- Circuit Diagram

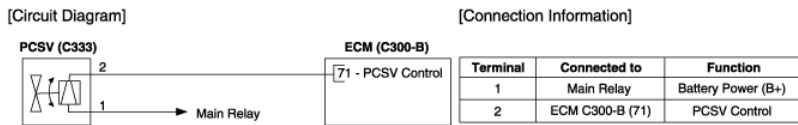

[Harness Connector]

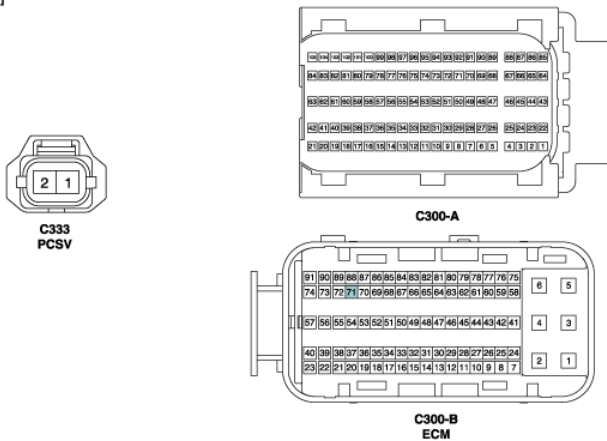

Purge Control Solenoid Valve (PCSV) - Repair Procedures (Article 44156)

- Inspection
- Turn the ignition switch OFF.

- Disconnect the PCSV connector.
- Measure resistance between the PCSV terminals 1 and 2.
- Check that the resistance is within the specification. Specification : Refer to "Specification"
- Removal
- Turn the ignition switch OFF and disconnect the battery negative (-) cable.
- Disconnect the purge control solenoid valve connector (A).
- Disconnect the vapor hoses (B) from the purge control solenoid valve .
- Remove the valve (C) from the surge tank after pulling it.

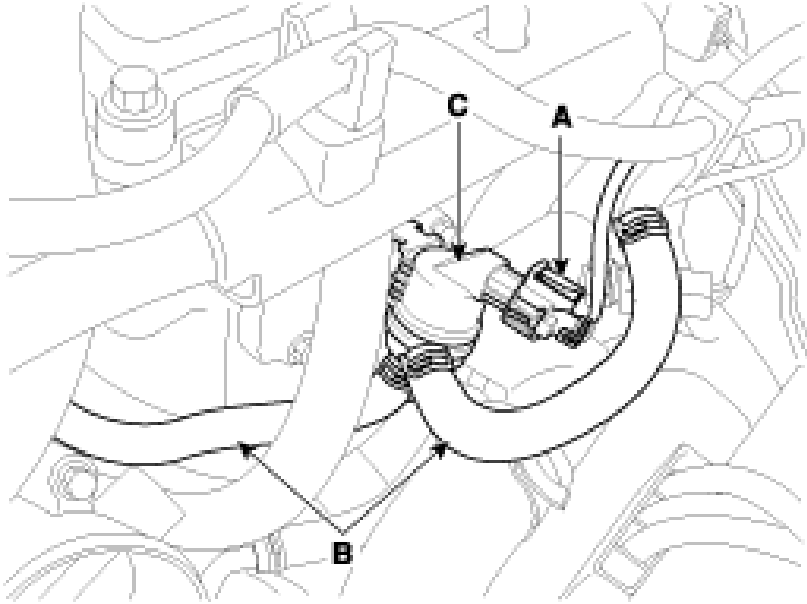

- Installation

Install the component with the specified torques. Note that internal damage may occur when the component is dropped. In this case, use it after inspecting.



- Install the component with the specified torques.
- Note that internal damage may occur when the component is dropped. In this case, use it after inspecting. Use care to keep foreign material out of the valve.
- Use care to keep foreign material out of the valve.
- Installation is reverse of removal. Purge control solenoid valve bracket installation bolt : 9.8 ~ 11.8 N.m (1.0 ~ 1.2 kgf.m, 7.2 ~ 8.7 lb-ft)

Purge Control Solenoid Valve (PCSV) - Specifications (Article 44152)

- Specification

Item Specification

Coil Resistance (Ω) 22.0 ~ 26.0 [20°C (68°F)]