

# Component Procedures: Radiator Cooling Fan

## Table of Contents

1. Parts and Labor (itype\_189)
2. Cooling Fan - Schematic Diagrams (Article 45366)
3. Cooling Fans (Article 11145)
4. Cooling Fan - Components and Components Location (Article 45362)
5. Cooling Fan - Repair Procedures (Article 45367)
6. Cooling Fan - Specifications (Article 45364)
7. Cooling Fan - Specifications (Article 45363)

# Component Procedures: Radiator Cooling Fan

## Parts and Labor (itype\_189)

### Parts

Qualifier	Part #	Name	Price	Note
Cooling Fan > Fan Assembly	25380F2000	11 - Fan Assembly	486.63	
Cooling Fan > Fan Blade	25231F2000	8 - Fan Blade	73.32	
Cooling Fan > Fan Motor	25386F2000	9 - Fan Motor	246.82	
Cooling Fan > Fan Shroud	25350F2000	10 - Fan Shroud	185.97	
Cooling Fan > Resistor	25385F2000	12 - Resistor	76.68	

### Labor

Operation	Qualifier Path	Skill	Std Hrs	Wty Hrs
Remove & Replace	Cooling Fan > Fan Assembly, R&R	B	1.4	0.0
Remove & Replace	Cooling Fan > Fan Blade, R&R	B	1.4	0.0
Remove & Replace	Cooling Fan > Fan Motor, R&R	B	1.4	0.0

## Cooling Fan - Schematic Diagrams (Article 45366)

### - Circuit Diagram

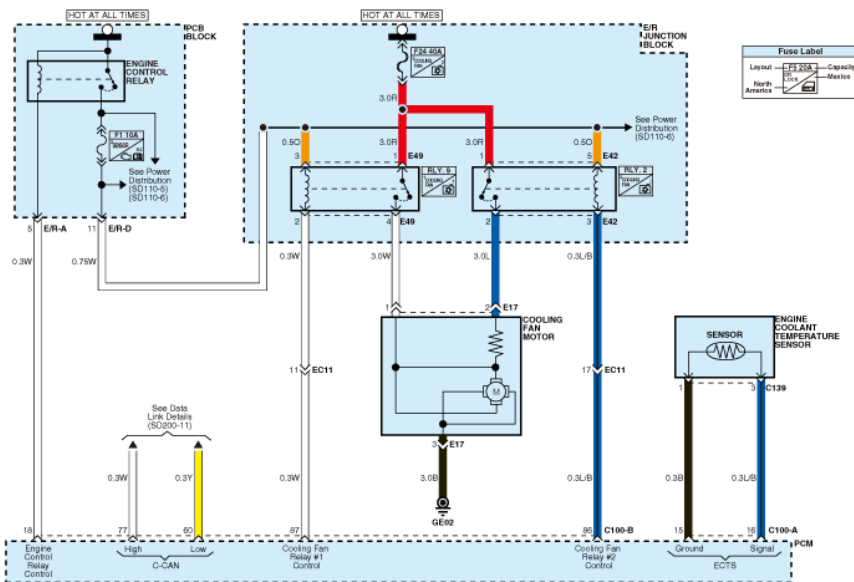

## Cooling Fans (Article 11145)

Cooling Fan s

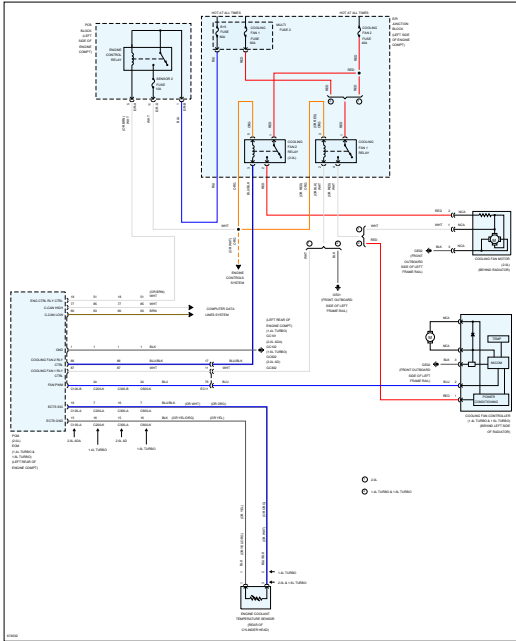

## Cooling Fan - Components and Components Location (Article 45362)

- Components

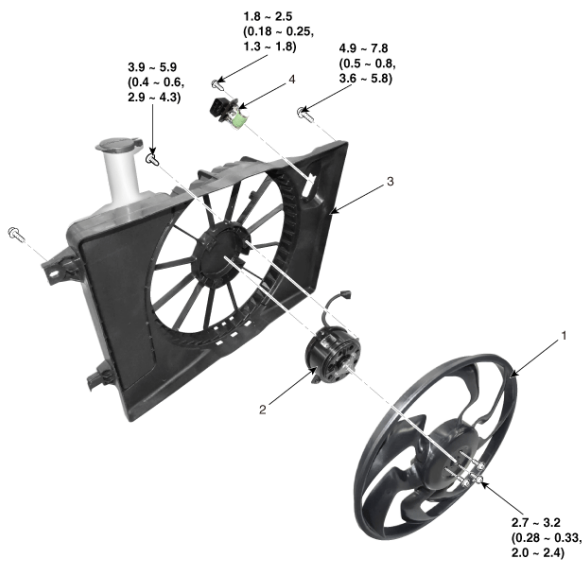

Tightening torque : N.m (kgf.m, lb-ft)

1. Cooling fan 2. Fan motor 3. Cooling fan shroud 4. Cooling fan resistor

## Cooling Fan - Repair Procedures (Article 45367)

- Removal and Installation

Cooling fan assembly

- Disconnect the battery negative terminal.
- Remove the air duct and air cleaner assembly . (Refer to Intake and Exhaust System - "Air Cleaner")
- Disconnect the over flow hose (A).

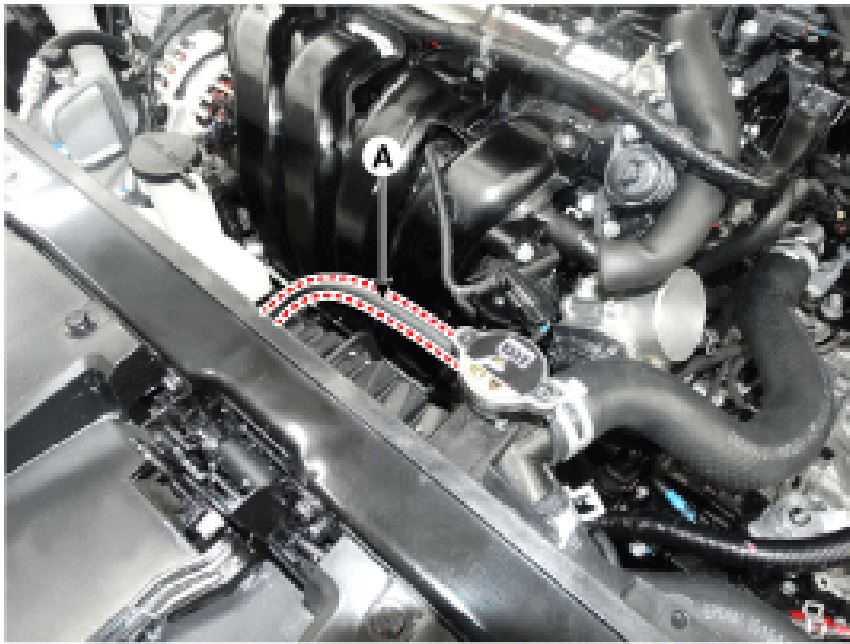

- Remove the filler neck assembly (A). Tightening torque : 3.9 - 5.9 N.m (0.4 - 0.6 kgf.m, 2.9 - 4.3 lb-ft)

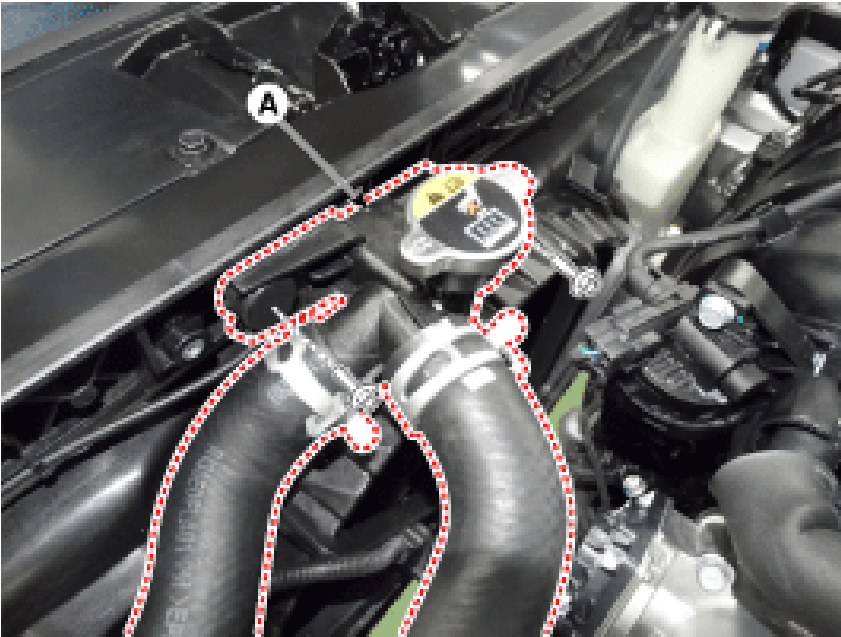

- Disconnect the variable intake solenoid (VIS) hose (A).

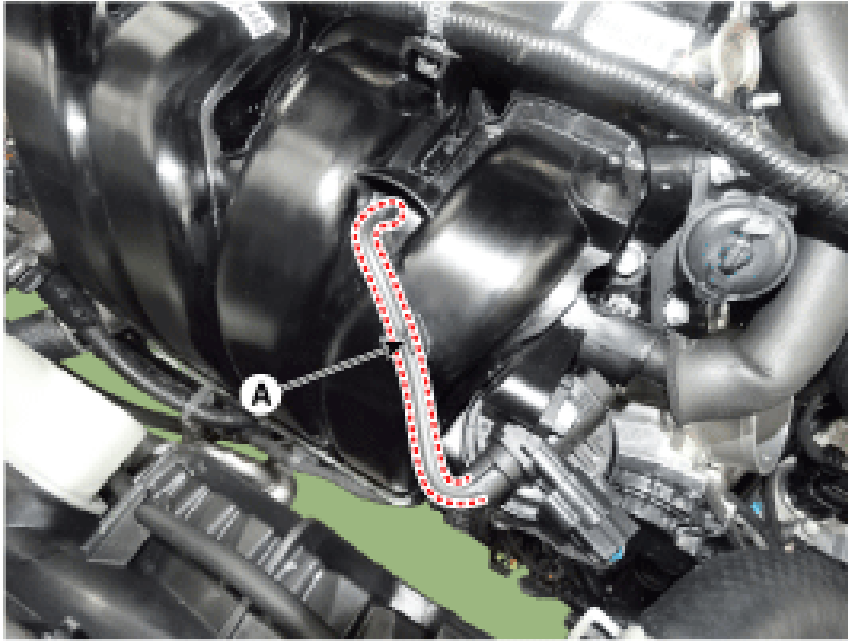

- Disconnect the wiring harness connector (A).

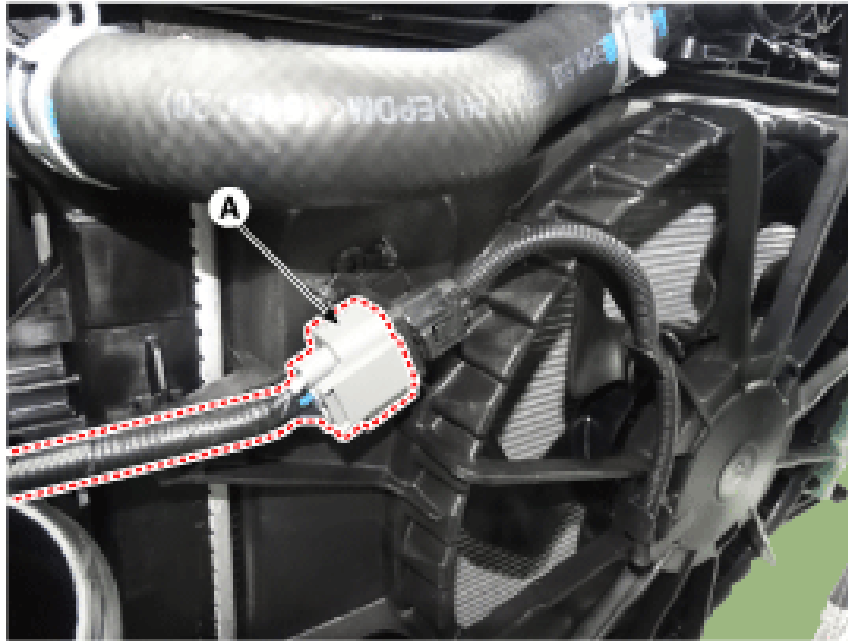

- Remove the intake shield (A). Tightening torque : 7.8 - 9.8 N.m (0.8 - 1.0 kgf.m, 5.8 - 7.2 lb-ft)

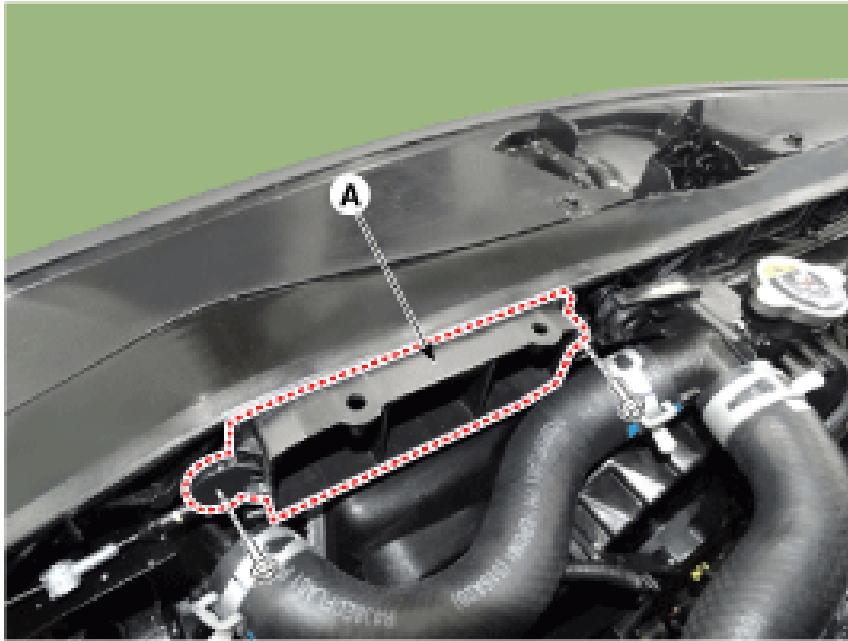

- Remove the cooling fan assembly (A). Tightening torque : 4.9 - 7.8 N.m (0.5 - 0.8 kgf.m, 3.6 - 5.8 lb-ft)

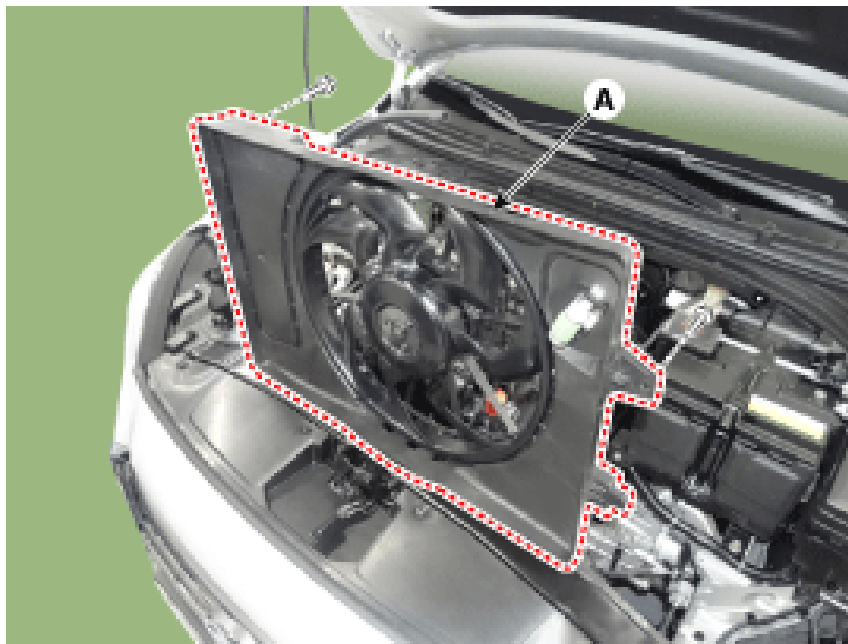

- Install in the reverse order of removal.

Resistor

- Disconnect the wire harness connector (A) and the fan motor connector (B).

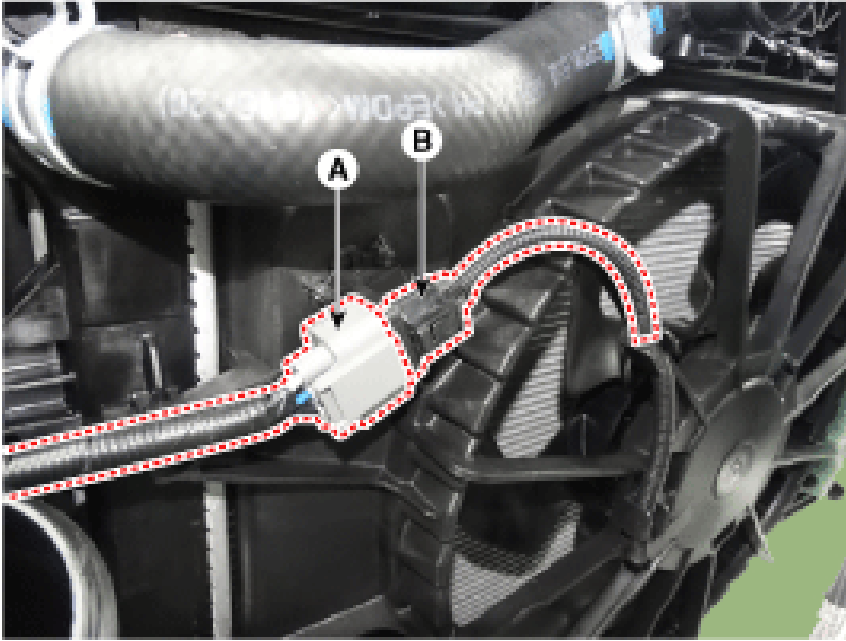

- Remove the resistor (A) from the cooling fan shroud . Tightening torque : 1.8 - 2.5 N.m(0.18 - 0.25 kgf.m, 1.3 - 1.8 lb-ft)

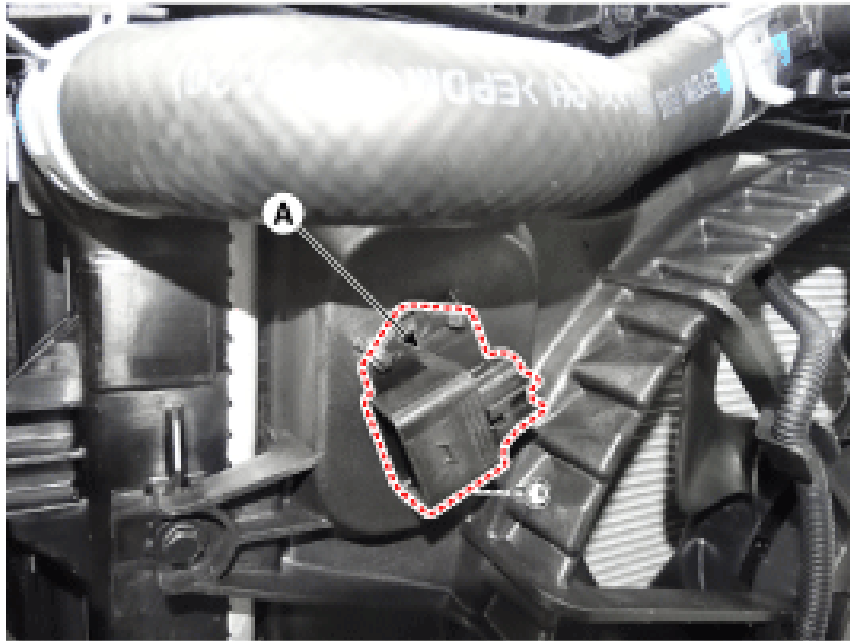

- Disassembly  
- Remove the cooling fan (A) from the cooling fan assembly. Tightening torque : 2.8 - 3.2 N.m (0.28 - 0.33 kgf.m, 2.0 - 2.4 lb-ft)

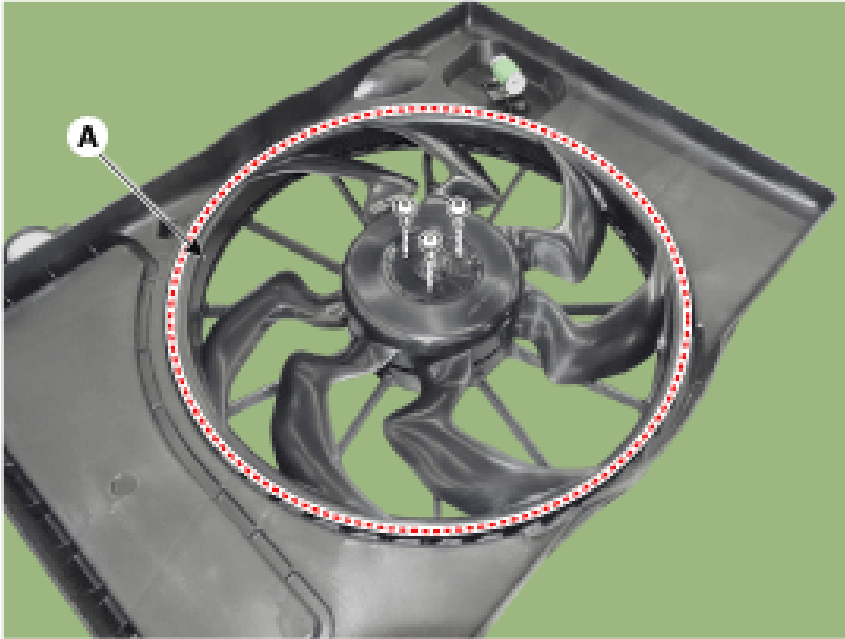

- Disconnect the fan motor connector (A) from the resistor and then remove the fan motor (B). Tightening torque : 3.9 - 5.9 N.m (0.4 - 0.6 kgf.m, 2.9 - 4.3 lb-ft)

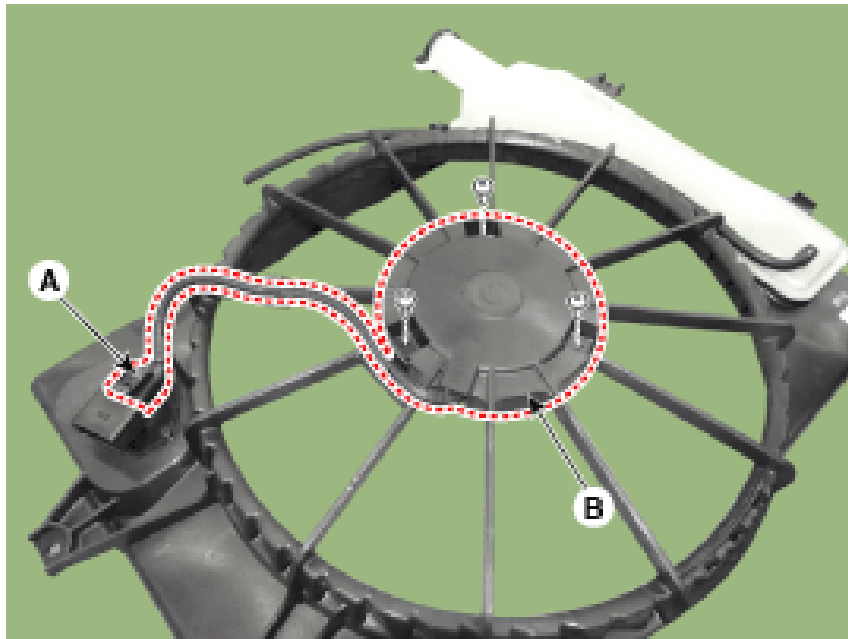

- Assemble in the reverse order of disassembly.
- Inspection
- Fan Motor
- Disconnect the fan motor connector from the resistor.
- Connect the battery voltage to the "+" terminal and ground to "-" terminal.
- Check the cooling fan motor operates well.

### Cooling Fan - Specifications (Article 45364)

- Specifications
- Item Specification
- Fan type Puller
- Fan speed control Resistor (HI-LOW-OFF)
- Air flow rate [m<sup>3</sup>/h (yd<sup>3</sup>/h)] 1,950 -8% min.
- Fan speed (rpm) 1,650 ± 8%
- Current (A) 11.7 + 10% max.

## **Cooling Fan - Specifications (Article 45363)**

- Specifications

Item Specification

Fan type Puller

Fan speed control Resistor (HI-LOW-OFF)

Air flow rate [m<sup>3</sup>/h (yd<sup>3</sup>/h)] 1,950 -8% min.

Fan speed (rpm) 1,650 ± 8%

Current (A) 11.7 + 10% max.